

**Building Passion,  
Building Solutions.**  
Panasonic Air Conditioning Systems



Do not add or replace refrigerant other than the specified type.  
Manufacturer is not responsible for the damage and deterioration in  
safety due to usage of other refrigerant.

• Specifications are subject to change without prior notice for further improvement • The contents of this catalogue are effective as of October 2015  
• Due to printing considerations, the actual colours may vary slightly from those shown • All graphics are provided merely for the purpose of illustrating a point.



NEW VRF  
SYSTEMS

2016 / 2017

**Building Passion,  
Building Solutions.**  
Panasonic Air Conditioning Systems





# **Building Passion, Building Solutions.**

## **Panasonic Air Conditioning Systems**

It's time to ride the wind.

In today's ever changing business environment, choosing the right air conditioning system and the right company to partner with can determine levels of success of a business project. If you want to succeed, you need a partner with passion that offers flexible solutions to drive that success.

And, during times of uncertainty, driving change as a "Game Changer" is the optimum means to take on challenges head on and emerge victorious.

Panasonic is your partner for the future. We foresee the future and continuously innovate to develop future-proof air-conditioning solutions.

Standing at the forefront of innovation, maximising human potential, reliability and our uncompromising spirit, Panasonic aims to meet its customer needs head on; focused on not just meeting target KPIs, but moving people and businesses with our passion.

In all that we do, our goal is to provide an experience of true comfort for businesses and homes, helping to build business success for our clients - Building Passion and Building Solutions.

# THE GAME CHANGER



## VRF with Extraordinary Energy-Saving Performance and Powerful Operation EER 5.3\* (8HP model)

A game-changing VRF system delivering energy-saving performance, powerful operation, reliability and comfort surpassing anything previously possible.

It represents a true paradigm shift in air conditioning solutions. Taking quality to the extreme — that's the Panasonic challenge.

\* for Asia model

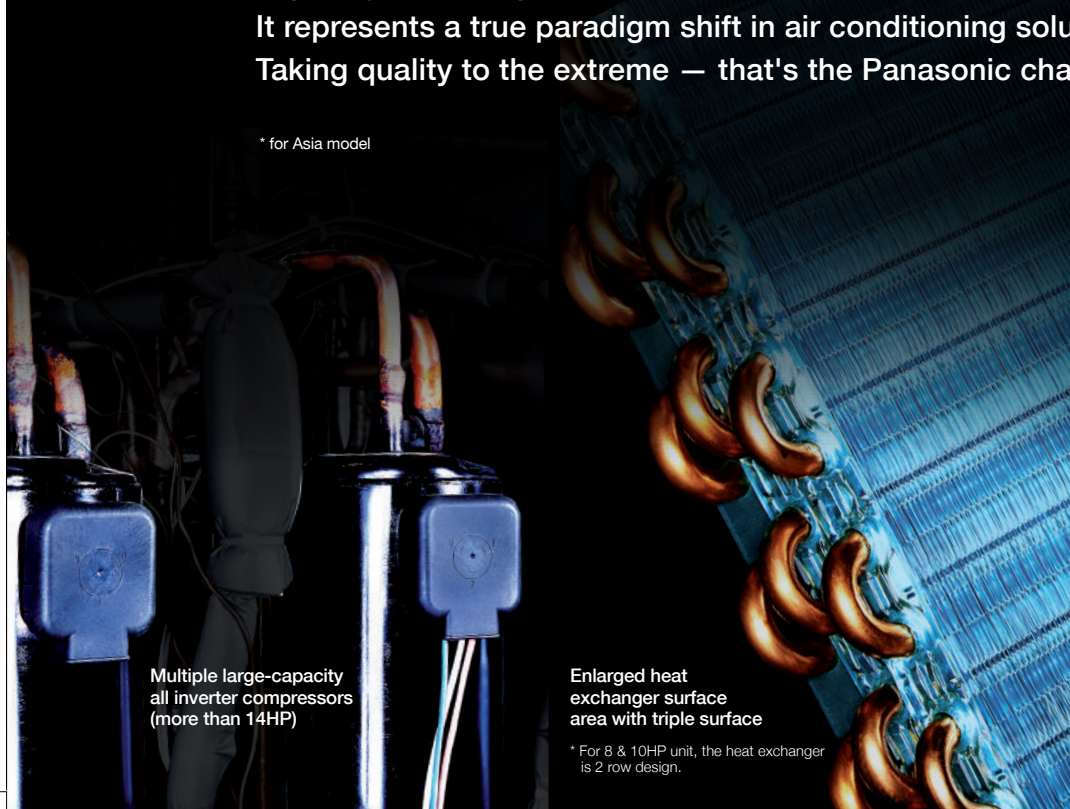

Multiple large-capacity all inverter compressors (more than 14HP)

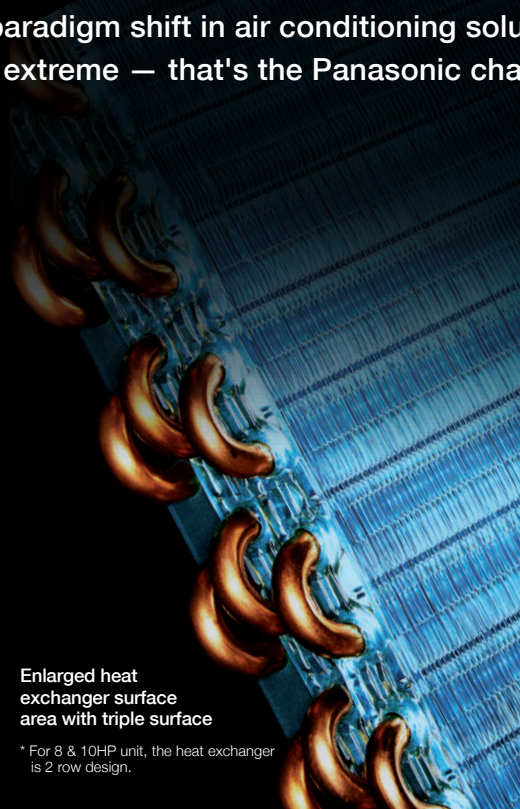

Enlarged heat exchanger surface area with triple surface

\* For 8 & 10HP unit, the heat exchanger is 2 row design.



Newly designed curved air discharge bell mouth for better aerodynamics

## CONTENTS

02 Promise to Our Customers	66 Indoor Units	106 Remark for High Static Ducted Series
04 Introduction	68 FSV Indoor Units Range	108 FSV Controllers
06 FSV-EX Advantages	70 F2 Type / Mid Static Ducted	110 Individual Control Systems
08 FSV-EX Series / Exclusive Feature 1 Extended Operation Range	74 M1 Type / Slim Low Static Ducted	113 Timer Operation
10 FSV-EX Series / Exclusive Feature 2 Energy-Saving Performance	76 Z1 Type / Slim Low Static Ducted Twenty Series	114 Centralised Control Systems
12 FSV-EX Series / Exclusive Feature 3 Oil Management System	78 E2 Type / High Static Ducted	115 Web Interface Systems
14 ECONAVI	80 E2 Type / Energy Saving High Fresh Air Ducted	118 P-AIMS
16 Exclusive Feature / High-spec Wired Remote Controller	82 E1 Type / High Static Ducted	120 T10 Terminal for External Control
20 Exclusive Feature / Air Handling Unit Kit	84 H1 Type / High-Fresh Air Ducted	121 Interfaces for External Control
24 Exclusive Feature / Design Support Software for FSV	86 K2-K1 Type Wall Mounted	122 Serial Interface for 3rd Party External Controller
26 New FSV Systems	90 U1 Type / 4-Way Cassette	123 Serial Interface for LonWorks Network
28 2-WAY FSV-EX ME2 Series	94 Y2 Type / 4-Way Mini Cassette	124 FSV Controller External Dimensions
44 2-WAY Mini-FSV LE1 Series	96 L1 Type / 2-Way Cassette	126 VRF Renewal
52 3-WAY FSV MF2 Series	98 D1 Type / 1-Way Cassette	130 A Globally Trusted Air Conditioning Brand
	100 T2 Type / Ceiling Mounted	132 Reliability and Durability
	102 P1 Type / Floor Standing	134 Global Networking of Air Conditioning Solutions
	104 R1 Type / Concealed Floor Standing	136 Panasonic VRF Global Project References



# FSV-EX Advantages



The most efficient, powerful and quiet system in Panasonic's history. There has never been a VRF system like it. It's the story of a true game changer.

**NEW**

## Extraordinary Energy-Saving Performance

The FSV-EX marks a revolutionary step forward in VRF efficiency. A look at the incredible EER value clearly indicates that. What's more, this high EER value is achieved even during part load operation. This shows the extraordinary energy-saving performance the FSV-EX is capable of providing.

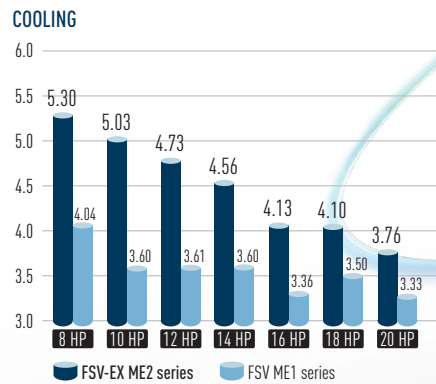

**Extraordinary EER**  
throughout the product range

**Extraordinary EER in Part load**  
throughout the product range



**NEW**

## Low-Noise Operation

Numerous technological innovations, including an improved compressor and a newly designed bell mouth and larger fan, have dramatically reduced the outdoor noise level. The result is an even more comfortable building environment.

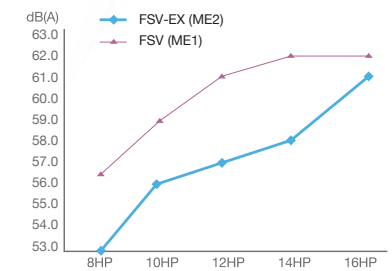

**NEW**

## Multiple large-capacity all inverter compressors (more than 14HP)

Two independently controlled inverter compressors achieve high efficiency. Redesigned components in the body provide performance improvement especially in the rated cooling condition and EER performance.



**NEW**

## Extended Operation Range Up to 52°C

The FSV-EX can provide cooling even when the outside temperature reaches a maximum of about 52°C. And amazingly, it can still operate at 100% capacity when the outside temperature is as high as 43°C. This high power capability enables reliable operation even under extremely high temperature conditions.

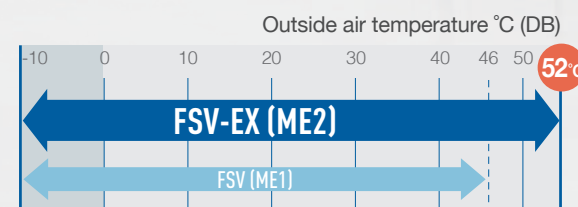

**NEW**

## Enlarged heat exchanger surface area with triple surface\*

The new heat exchanger features a triple-surface construction. Compared to the divided dual-surface construction in current models, there is no division of space and the area for heat exchange is larger. Also, highly efficient piping pattern increases heat exchange performance by 5%.

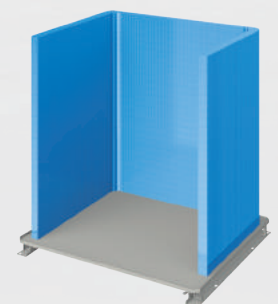

\* For 8 & 10HP unit, the heat exchanger is 2 row design.

# Extended Operation Range up to 52°C



## High reliability even under high temperature conditions

Designed to be durable enough to withstand extreme heat, FSV EX ensures reliable cooling operation over an extended operation range up to 52°C.

## Full-capacity Operation up to 43°C

The FSV-EX can provide cooling even when the outside temperature reaches a maximum of about 52°C. And amazingly, it can still operate at 100% capacity when the outside temperature is as high as 43°C. This high power capability enables reliable operation even under extremely high temperature conditions.

### OPERATING RANGE

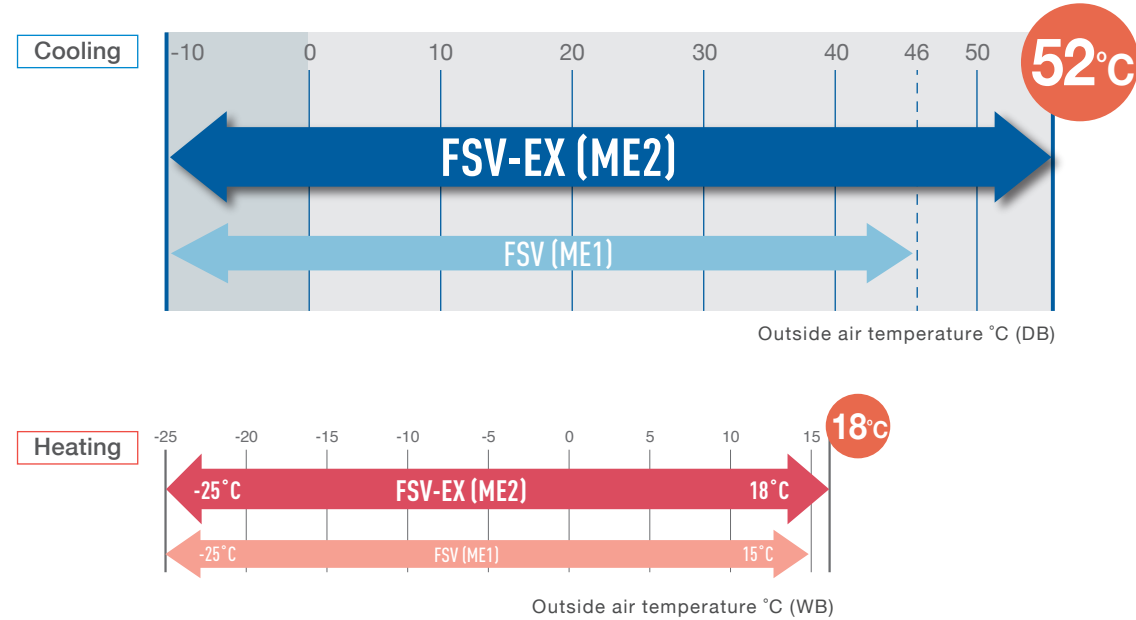

### CAPACITY RATIO (COOLING)

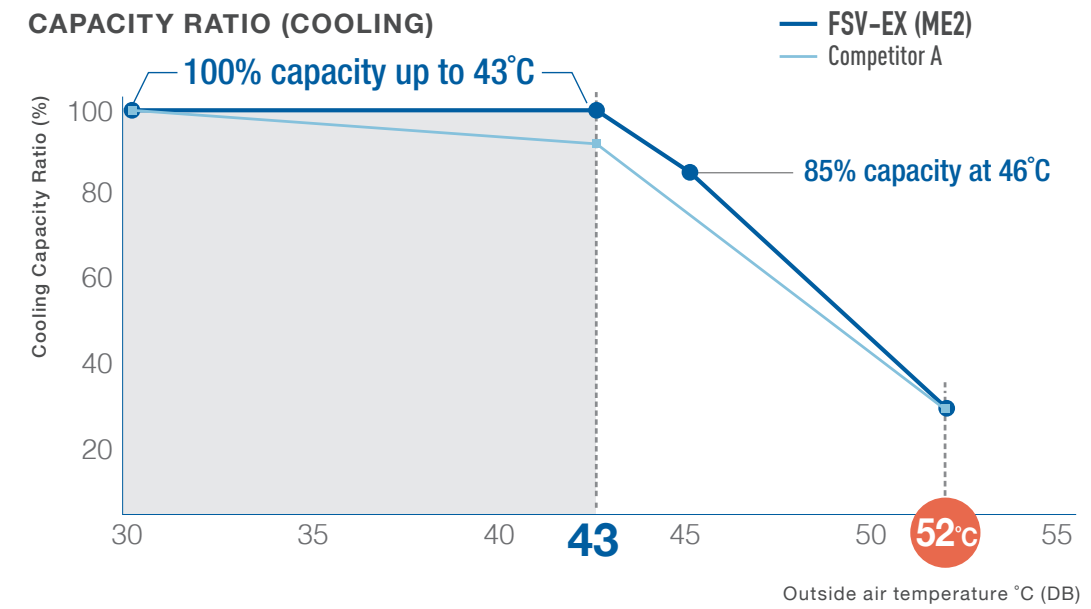

<Test Condition> 12HP model, IU/OU capacity ratio:100%, Indoor Condition:27°C(DB)/19°C(WB)  
Competitor A spec is from technical data book.



# Extraordinary Energy-Saving Performance



## Practical Design for Actual Operation

Panasonic builds air conditioning systems not only with a high EER for rated operation, but also with Seasonal-EER appropriate to the customer's actual environment of use. For instance, with rated operation, outdoor temperature is constant at 35°C, but in reality the outdoor temperature is continuously changing. Consequently, required air conditioning performance also changes. That's why Panasonic implements the following kind of proprietary control.

1. Set temperature is rapidly attained; full-load operating time is kept to a minimum.
2. The frequency of forced oil recovery is minimised. The volume of oil within the compressors is monitored precisely by sensors, so forced oil recovery under full-load operation is conducted only when necessary. Since this suppresses noise due to oil recovery, comfort is maintained.
3. Panasonic pursues a high EER, of course, as well as high EER in part load, for energy saving performance under a broad range of loads.

Panasonic's design concept contributes to substantial energy cost reductions.

Rapidly reaches set temperature  
→ full-load operation duration minimised

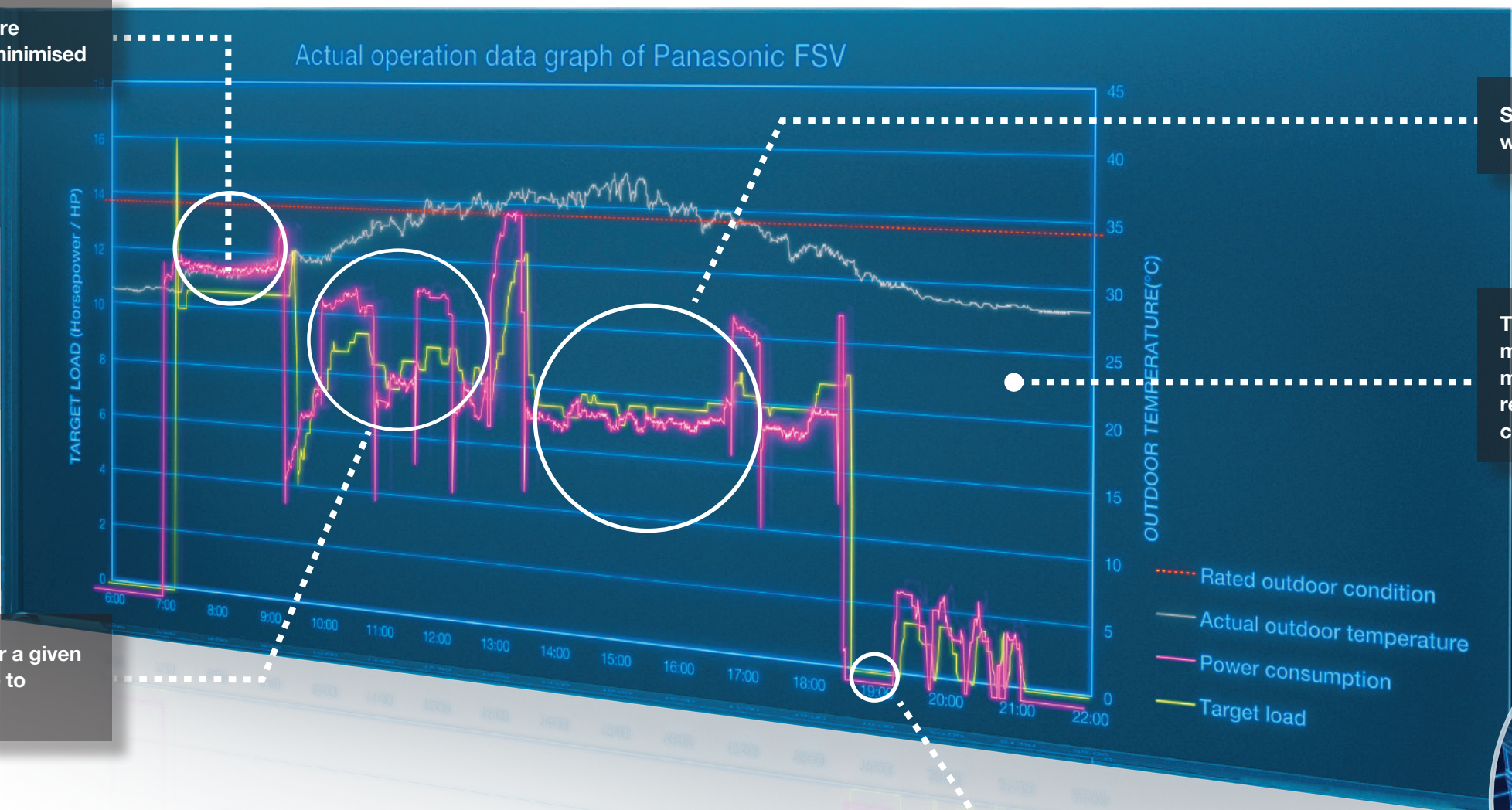

Load increased as required for a given outdoor temperature increase to maintain the set temperature

Set temperature maintained with minimum load operation

Thanks to superior oil management, oil recovery is minimised, contributing to reduced energy use and costs

When outdoor temperature drops, operation is immediately stopped

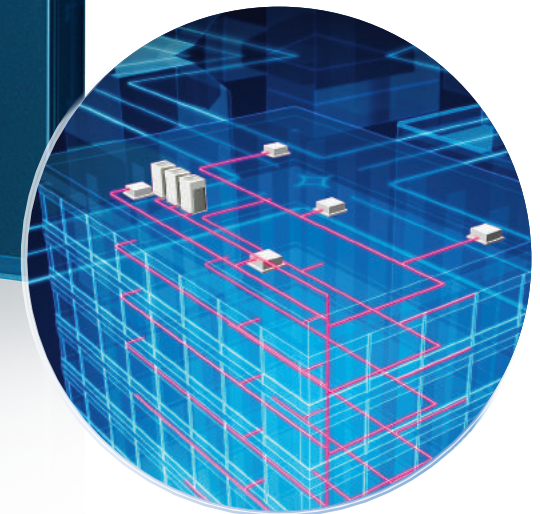

## Actual performance data of Panasonic FSV installed in Asia

Simulated conditions  
Location: Panasonic building in Malaysia System: One 16HP outdoor unit, 4 cassette-type indoor units

# Intelligent 3-stage Oil Management System



In a VRF system, where lengthy piping and a large number of indoor units need to be controlled collectively, the key to maintaining the system's reliability is to ensure an appropriate amount of oil is secured in the compressors. In order to avoid oil shortage in the compressor, maximum operation is normally forcibly conducted at regular intervals to recover oil from indoor units. This method, typically employed in a standard VRF, causes the system to overheat or overcool and thus waste energy.

In Panasonic VRF systems, a sensor for detecting oil levels is mounted in each compressor. In installations with multiple outdoor units, a shortage of oil in one compressor can be compensated for by recovering oil either from another compressor in the same unit, from a compressor in an adjacent outdoor unit, or from a connected indoor unit. Panasonic VRF systems provide users with a comfortable environment whilst saving energy.

The Panasonic system efficiently manages oil recovery in three stages; minimising the frequency of forced oil recovery while reducing energy cost and maintaining comfort.

## STAGE-1

Panasonic compressors are equipped with sensors which monitor oil levels precisely at all times. If oil levels fall, oil can be transferred from other compressors within the same outdoor unit.



## STAGE-2

If oil levels in all compressors within the outdoor unit fall, oil can be replenished from adjacent outdoor units.

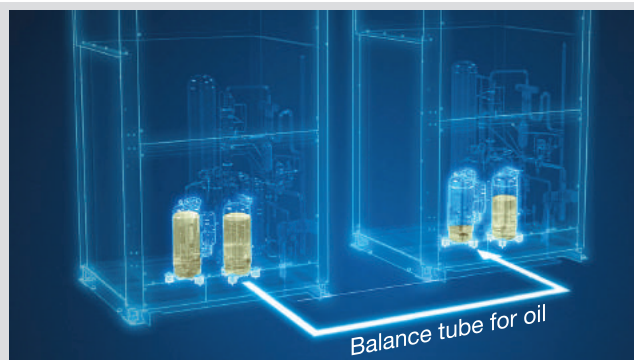

## STAGE-3

Forced oil recovery is implemented only if oil levels become insufficient in spite of above measures. The Panasonic system's design concept is radically different from conventional oil systems.

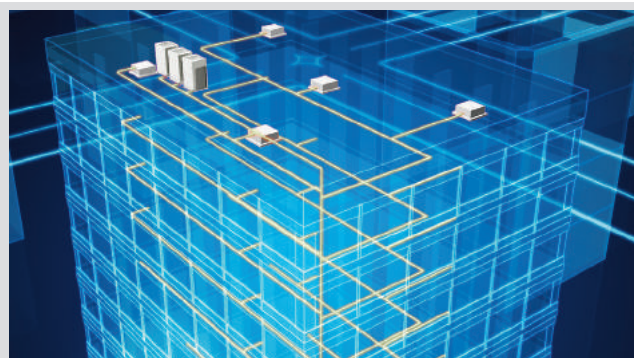

## Features of 3-stage oil recovery design

### 1 Oil sensors installed in each compressor

Oil sensors installed in each Panasonic compressor precisely monitor oil levels, eliminating unnecessary oil recovery.

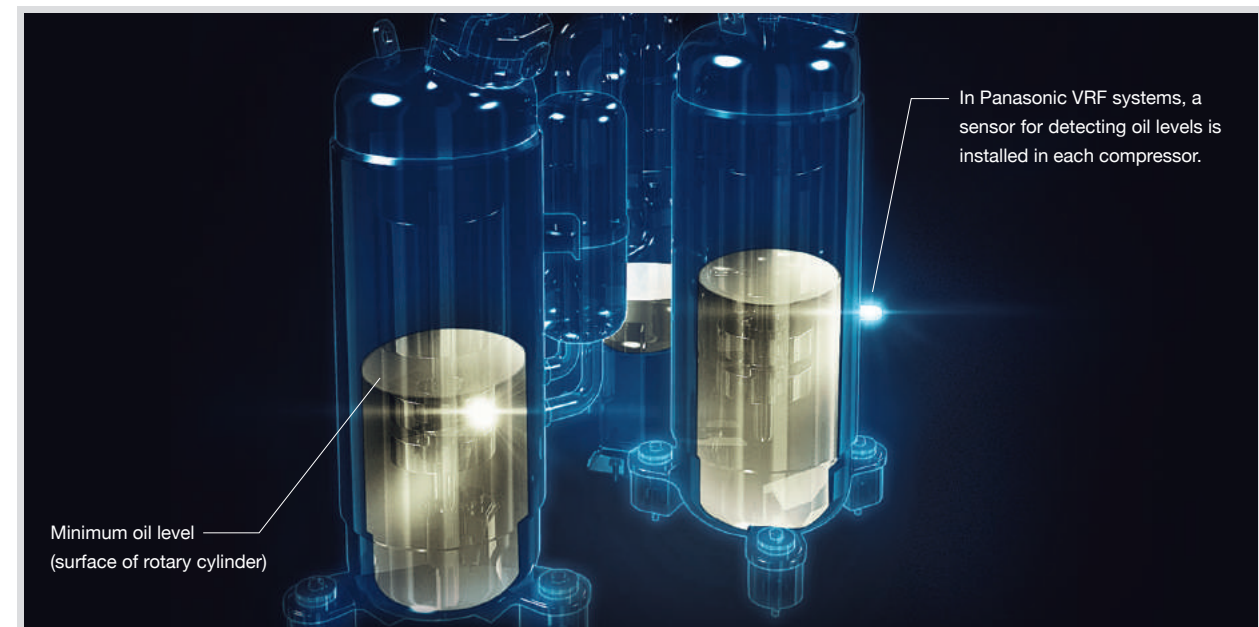

### 2

### Highly functional oil separator

Thanks to extended separate piping, oil recovery efficiency reaches 90%, minimising the oil to be discharged from the compressor.



# ECONAVI Detects Inefficiencies and Saves Energy

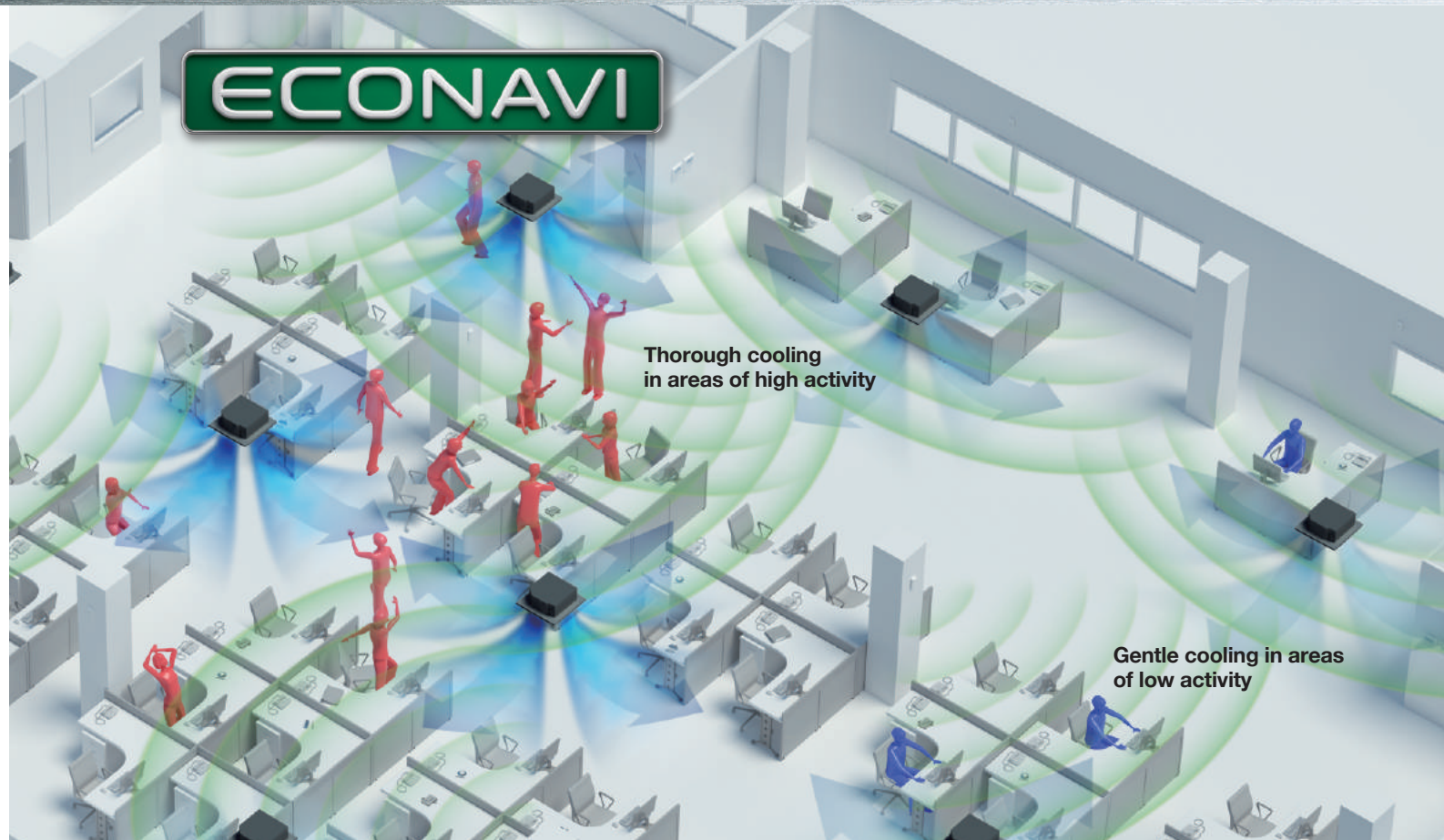

## ECONAVI

### Remote ECONAVI sensor allows optimum energy operation

Pillars, walls, cabinets and other fittings obstruct the sensor, reducing the area of detection and lowering the energy-saving effect. Taking into consideration blind spots, Panasonic enables the optimum layout for sensors in any office.



ECONAVI sensor CZ-CENSC1

### Panasonic enables use with various types of indoor units

Providing outstanding energy-saving performance, Panasonic's inverter VRF System can be connected to ECONAVI to detect when energy is being wasted. ECONAVI senses the presence or absence of people and the level of activity in each area of an office. When unnecessary heating or cooling is detected, indoor units are individually controlled to match office conditions for energy-saving operation.

### Wide detection area

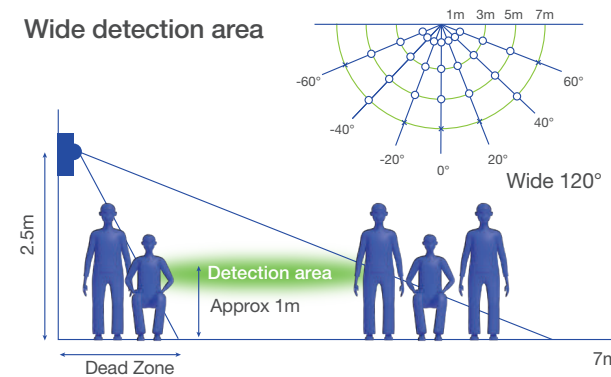

A sensor is remotely set to maximise the detection area.

Installation flexibility ready for indoor unit replacement and layout changes.

### Detection of the level of activity enables precise power saving.

Presence or absence of people at their desks and the level of activity in the office are detected in real time. Set temperature is automatically adjusted to optimise the lower power consumption.

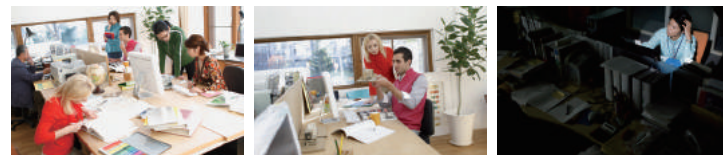

- In the morning**: Thorough cooling when there is a high level of activity
- In the afternoon**: Reduced cooling when there are fewer people
- At night**: Automatic Thermo Off depending on conditions at the end of the day\*

### Human activity and presence detection

Activity detection		Presence detection	
HIGHER ACTIVITY	LOWER ACTIVITY	After 20 mins absence	After 3 hours absence
Cooling Set Temp. +/-0°C	Cooling Set Temp. +1°C	Cooling Set Temp. +2°C	Cooling Thermo OFF*
Heating Set Temp. -1°C	Heating Set Temp. +/-0 °C	Heating Set Temp. -2°C	Heating Thermo OFF*
Every 2 min	Every 2 min	After 3 hours the setting can change to Stop or Temperature Shift	

\*Depending on conditions, the setting can change to Switch Off After 3 Hours, Thermo Off or Temperature Shift.

### ECONAVI VRF Field Test

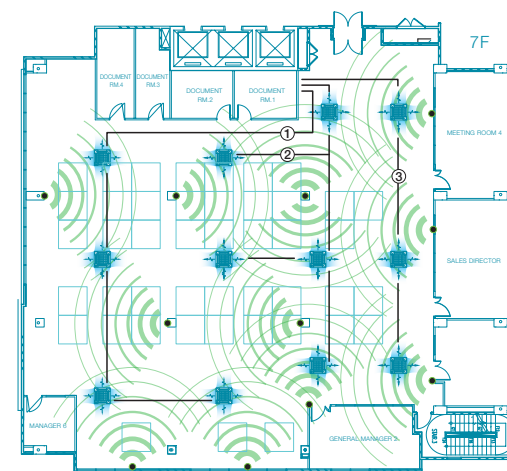

- Indoor units (12)
- Sensors (12)
- Trial term: 11 Apr - 16 May 2014
- Location: Panasonic Malaysia Building
- Office floor: Cooling capacity 112kW
- Testing conditions:
  - Remote controller setting temperature 23°C
  - Setting time AM7:00-PM21:00
- Units used

System	Outdoor unit	Indoor unit
① CU-L7-6	U-20ME1E8	1 S-106MU1E5
		2 S-106MU1E5
		3 S-106MU1E5
② CU-L7-7	U-20ME1E8	4 S-106MU1E5
		5 S-56MU1E5
		6 S-106MU1E5
		7 S-106MU1E5
		8 S-56MU1E5
③ CU-L7-7	U-14ME1E8	9 S-106MU1E5
		10 S-106MU1E5
		11 S-56MU1E5
		12 S-106MU1E5



### Power consumption



Up to **15%** energy saving

Energy-saving effect tested and verified by Field test



# High-spec Wired Remote Controller

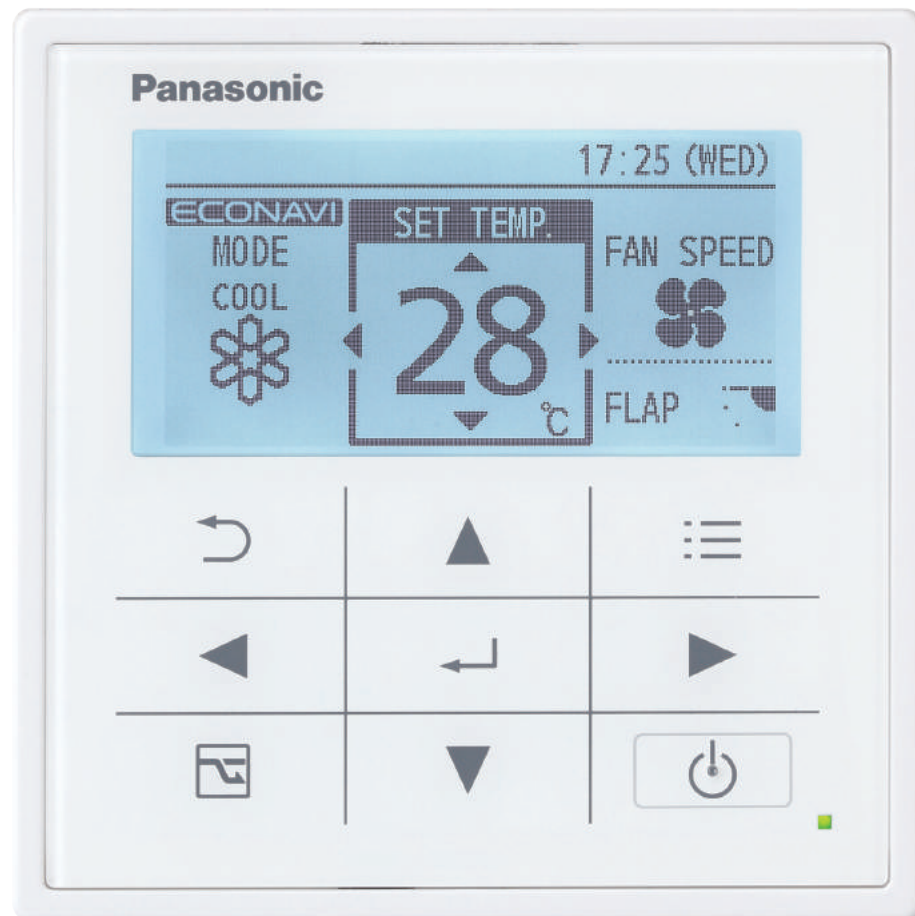

CZ-RTC5 Actual size

## Large 3.5" Full-dot LCD with White LED Backlight

Characters and icons are clearly displayed for improved visibility. The display is also large enough to provide a wide range of information for easy confirmation of operation conditions.

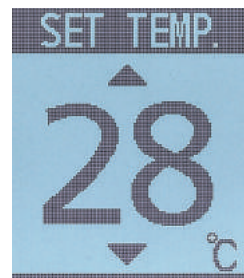

## Stylish, Easy-to-use Touch Key Design

The elegant, flat design features large touch keys in a simple layout enabling easy, intuitive operation.



## Multiple control settings to meet a wide range of air conditioning needs

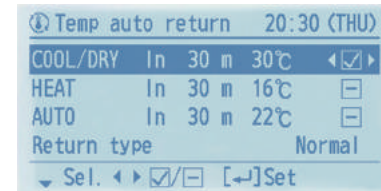

### Temperature Auto Return

Even if you change the temperature setting, after a set time it automatically returns to the original temperature setting. You can set temperature auto return time in 10-minute intervals within a period of 4 hours.

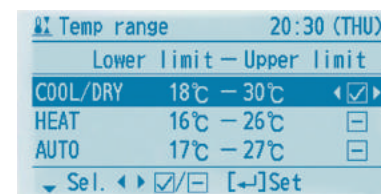

### Temperature Setting Range

You can set the upper and lower temperature limits. Doing this helps reduce power consumption due to over cooling or heating. Setting is possible in the Cooling, Heating and Dry modes.

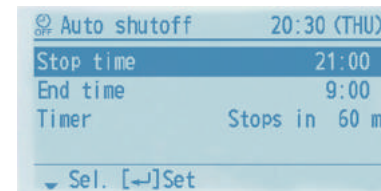

### Auto Shutoff

Air conditioning automatically stops after a set time, so you don't have to worry about forgetting to switch the unit off. Even if you manually switch the unit back on after it has stopped, it automatically switches off again after the set time.

## Wide range of controls for extra convenience

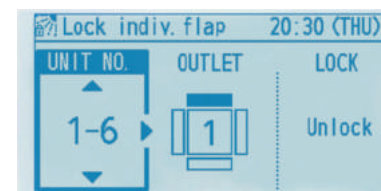

### Individual Louver Control

(Lock individual flap only for 4-way cassette U1 type)

Each of the 4-directional outlets can be selected and locked to provide efficient air distribution that matches the indoor unit layout. Indoor units can be set individually.

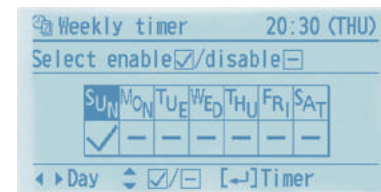

### Weekly Timer

This lets you specify 8 Start/Stop times and temperature presets for each day of the week.

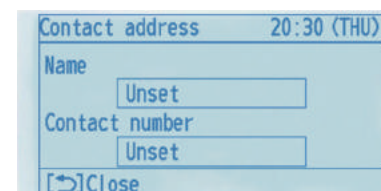

### Service Contact Address

Once you have register service contact details, they are automatically displayed if a problem with the air conditioner occurs. This helps you quickly deal with the situation.

## Convenient Controls



### Operation Lock

To prevent operation by anyone other than the supervisor, operation keys can be locked. This prevents unauthorized personnel from changing temperature settings, airflow rate, airflow direction and other settings.



### Filter Information

Filter information is indicated for cleaning after a set time of operation period has past. The number of hours can be adjusted.

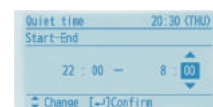

### Quiet Operation Mode

There's a Quiet mode that reduces the outdoor unit's operating noise. The mode can be switched On/ Off and Start/ End times can be set.

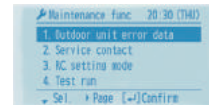

### Maintenance Function

Display of outdoor malfunction data, service contact details, filter cleaning remaining time and other data enables at-a-glance verification of maintenance information with the remote controller.

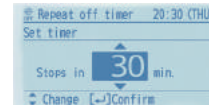

### Repeat OFF Timer

You can stop the operation after a certain period of time each time operation is performed.

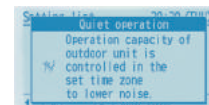

### Setting Lists

Information concerning current settings is displayed in the remote controller's LCD for easy confirmation.

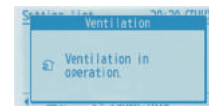
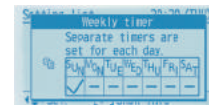

## Function List

	Control Item	Controllability	
		New "A" model	Non "A" model
Menu items	Basic instructions	●	●
	FLAP	●	●
	Individual louver control (Lock individual flap only for 4-way cassette U1 type)	●	●
	ON/ OFF timer	●	●
	Weekly timer	●	●
	Filter information	●	—
	Outing function	●	●
	Quiet operation mode	●	—
	Energy saving	●	●
	Initial settings	●	●
Energy Saving	Ventilation	●	●
	Temperature auto return	●	●
	Temperature setting range	●	●
	Auto shutoff	●	●
	Schedule peak cut	●	—
	Repeat off timer	●	●
Maintenance Function	ECONAVI on/ off	●	—
	Outdoor unit error data	●	—
	Service Contact address	●	●
	RC setting mode	●	●
	Test Run	●	●
	Sensor Information	●	●
	Service check	●	●
Simple/ Detailed Settings	●	●	
	Auto address	●	●



# Air Handling Unit Kit

AHU Kit connects FSV-EX and FSV outdoor units to Air Handling Units System

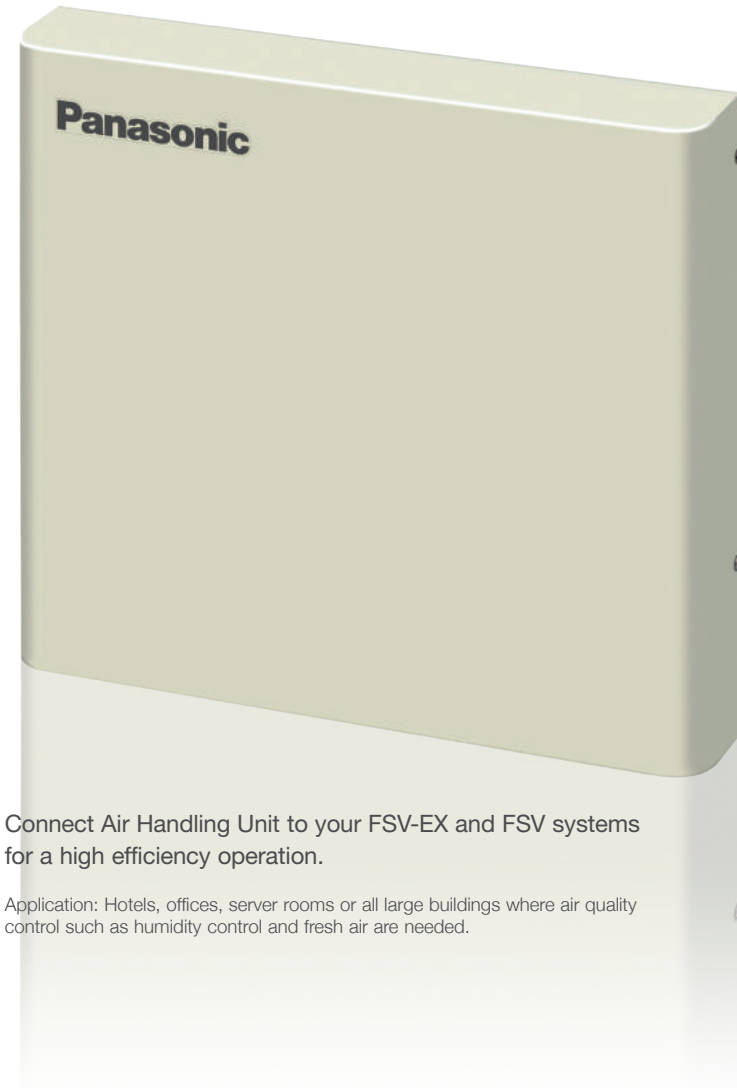

If you require this fresh air solution, please contact an authorized Panasonic distributor.

Connect Air Handling Unit to your FSV-EX and FSV systems for a high efficiency operation.

Application: Hotels, offices, server rooms or all large buildings where air quality control such as humidity control and fresh air are needed.

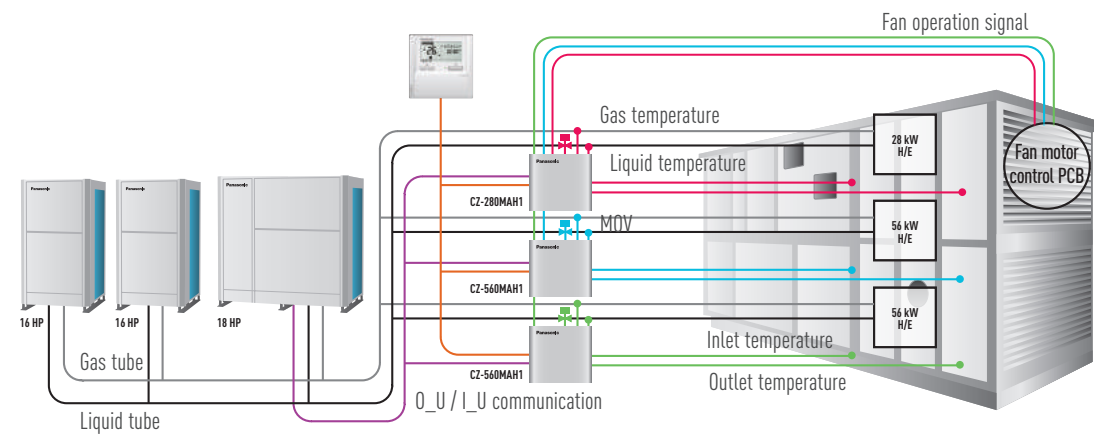

## AIR HANDLING UNIT Kit to connect to your ventilation system

### AHU Connection Kit

PCB, Power trans, Terminal block



Remote control can be easily installed on the AHU Kit box. (Remote control must be purchased separately.)



Expansion valve



Thermistor x2 (Refrigerant: E1, E3)

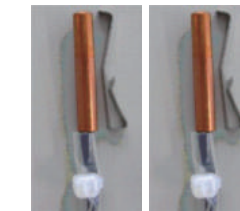

Thermistor x2 (x1 in PACi) (Air: Tf, Tb)

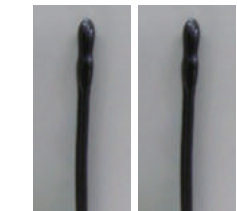

### Optional Remote controller

Timer remote controller. CZ-RTC4



### Optional parts: Following functions are available by using different type of control accessories:

#### CZ-RTC4 Wired remote controller

- Operation-ON/OFF
- Mode select
- Temperature setting
- \* Fan operation signal can be taken from the PCB.

#### T10 terminal

- Input signal= Operation ON/OFF
- Remote controller prohibition
- Output signal= Operating-ON status
- Alarm output (by DC12 V)

#### PAW-OCT, DC12 V outlet. Option terminal

- Output signal= Cool / Heat/Fan status
- Defrost
- Thermostat-ON

#### CZ-CAPBC2 Seri-para I/O unit for each indoor unit

- Temperature setting by 0-10 V or 0-140 Ω input signal
- Room (inlet air) temp outlet by 4-20 mA
- Mode select or/and ON/OFF control
- Fan operation control
- Operation status output/ Alarm output

#### Technical Zoom

- Max. piping length: 100m (actual)/ 120m (equivalent)
- Difference between longest and shortest piping from first branch: 10m
- Max. length of branch tubing: 12m
- \* Other conditions to be referred the standard piping design regulations.
- Available temperature range in Heating: -20 °C (WB)~15 °C (WB)
- Available temperature range for the suction air at AHU Kit: Cool: 18~32 °C / Heat: 16~30 °C

#### CZ-280MAH1 // CZ-560MAH1

- The system controlled by the suction air (or return air from room) temperature as same as standard indoor unit. (Selectable mode: Automatic / Cooling / Heating / Fan / Dry (but same as Cool))
- The discharge air temperature is also controlled to prevent too-low air discharge in Cooling or too-high air discharge in Heating. (in case of VRF system)
- Demand control (Forcible thermostat-OFF control by operating current)
- Defrost operation signal, Thermo-ON/OFF states output
- External target temperature setting via Indoor/Outdoor signal interface is available with CZ-CAPBC2. (Ex. 0 - 10 V)
- Connectable with P-LINK system
- Fan control signal from the PCB can be used for control the air volume (High/Mid/Low and LL for Th-off)

## System and regulations. System overview

- A: AHU Kit controller box (with control PCB)
- B: AHU equipment (Field supplied)
- C: Remote controller (option parts)
- D: Outdoor unit
- E: Gas piping (Field supplied)
- F: Liquid piping (Field supplied)
- G: Electronic expansion valve
- H: Thermistor for Gas pipe (E3)
- I: Thermistor for Liquid pipe (E1)
- J: Thermistor for Suction air (TA)
- K: Thermistor for Discharge air (BL)
- L: Inter unit wiring
- M: Magnetic relay for operating the blower (Field supplied)

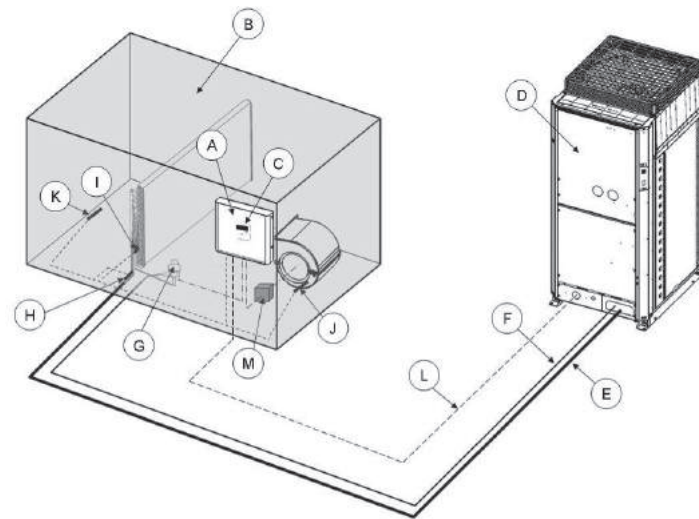

## Project References

### Office Hong Kong Red Cross Headquarters



Air Conditioning System:  
VRF 2-way FSV ME1 series:  
2 systems  
Indoor Units: 2 units  
AHU Kit: 6 units  
Cooling Capacity: 280 kW / 80 USRT



### Residential + Commercial Malaysia Utropolis, Glenmarie



Air Conditioning System:  
VRF 2-way FSV ME1 series:  
29 systems  
Indoor Units: 168 units  
AHU Kit: 9 units  
Cooling Capacity: 3,077 kW / 875 USRT



AHU CONNECTION KIT, 28 kW AND 56 kW FOR FSV	Cooling capacity	Heating capacity	Horsepower	Cooling Airflow	Bypass Factor	Dimensions of the box	Piping length	Elevation diff. (in/out)	Pipe Diameters		Intake temperature of AHU Kit	Ambient temperature of outdoor unit
	Nominal	Nominal		Max / Min			Min / Max	Max	Liquid pipe	Gas pipe	Min / Max	Min / Max
	kW	kW		m <sup>3</sup> /min			m	m	Inch (mm)	Inch (mm)	°C	°C
CZ-280MAH1	28.0	31.5	10	5,000 / 3,500	0.9 (recommended)	404 x 425 x 78	10 / 100	50	3/8 (9.52)	7/8 (22.22)	Cooling: 18 - 32DB (13 - 23 WB) / Heating: 16 - 30 DB	Cooling: -10 - 43 DB / Heating: -20 - 15 WB
CZ-560MAH1	56.0	63.0	20	10,000 / 7,000	0.9 (recommended)	404 x 425 x 78	10 / 100	50	5/8 (15.88)	1 1/8 (28.58)		
CZ-280MAH1 + CZ-560MAH1	84.0	95.0	30	15,000 / 10,500	0.9 (recommended)	404 x 425 x 78	10 / 100	50	3/4 (19.05)	1 1/4 (31.75)		
CZ-560MAH1 x2	112.0	127.0	40	20,000 / 14,000	0.9 (recommended)	404 x 425 x 78	10 / 100	50	3/4 (19.05)	1 1/2 (38.15)		
CZ-560MAH1 x2 + CZ-280MAH1	140.0	155.0	50	25,000 / 17,500	0.9 (recommended)	404 x 425 x 78	10 / 100	50	3/4 (19.05)	1 1/2 (38.15)		
CZ-560MAH1 x3	168.0	189.0	60	30,000 / 21,000	0.9 (recommended)	404 x 425 x 78	10 / 100	50	3/4 (19.05)	1 1/2 (38.15)		

AHU Connection Kit / System Combination							
2-Way FSV-EX ME2 SERIES	Capacity (HP)	Outdoor unit combination			AHU kit combination		
		28 kW (10 HP)	U-10ME2H7			CZ-280MAH1	
	56 kW (20 HP)	U-20ME2H7			CZ-560MAH1		
	84 kW (30 HP)	U-16ME2H7	U-14ME2H7		CZ-560MAH1	CZ-280MAH1	
	112 kW (40 HP)	U-20ME2H7	U-20ME2H7		CZ-560MAH1	CZ-560MAH1	
	140 kW (50 HP)	U-18ME2H7	U-16ME2H7	U-16ME2H7	CZ-560MAH1	CZ-560MAH1	CZ-280MAH1
	168 kW (60 HP)	U-20ME2H7	U-20ME2H7	U-20ME2H7	CZ-560MAH1	CZ-560MAH1	CZ-560MAH1

# Design Support Software for FSV



Features the unique Mounting Scheme function providing more thorough spec-in and tender quotation support for easier, faster completion of work.

## The Panasonic VRF Designer software can be used for all Panasonic FSV ME2, LE1 and MF2

Panasonic has identified the importance of ever-increasing demands for fast and accurate responses to customer requests in our industry. More and more emphasis is being placed upon energy-efficiency in our marketplace. The ability to calculate cooling/heating loads and produce information of actual design conditions is a major advantage to any architect, consultant, contractor or end user. Panasonic understands the time-poor and demanding industry we are in and we are pleased to announce the launch of the next generation of our system design software program.

The Panasonic VRF Designer software has been customised to make the selection and design process as quick and easy as possible.

The design package utilises system wizards and import tools to enable both simple and complex systems to be created. In addition, the system will allow outdoor and indoor units to be dragged on an interactive desktop. This allows users to create everything from realistic floor plans with detailed piping and wiring schematics to send out with quotations, through to installation guidance drawings.

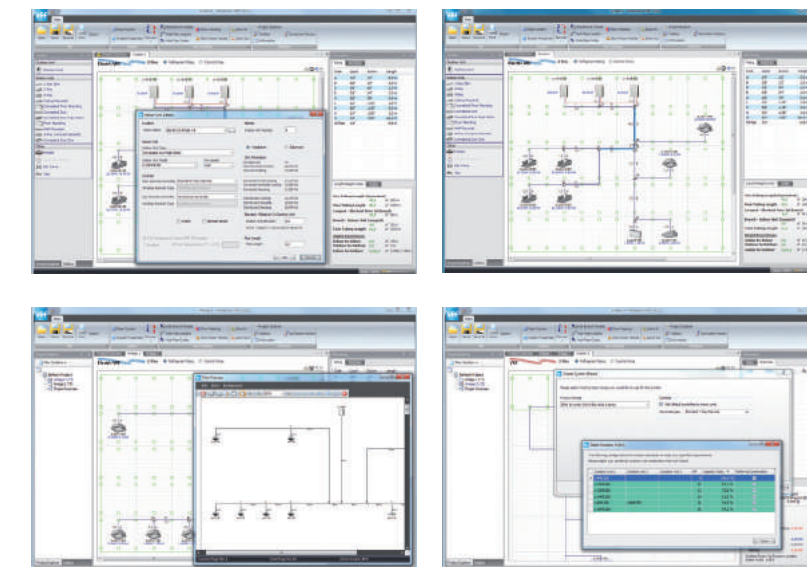
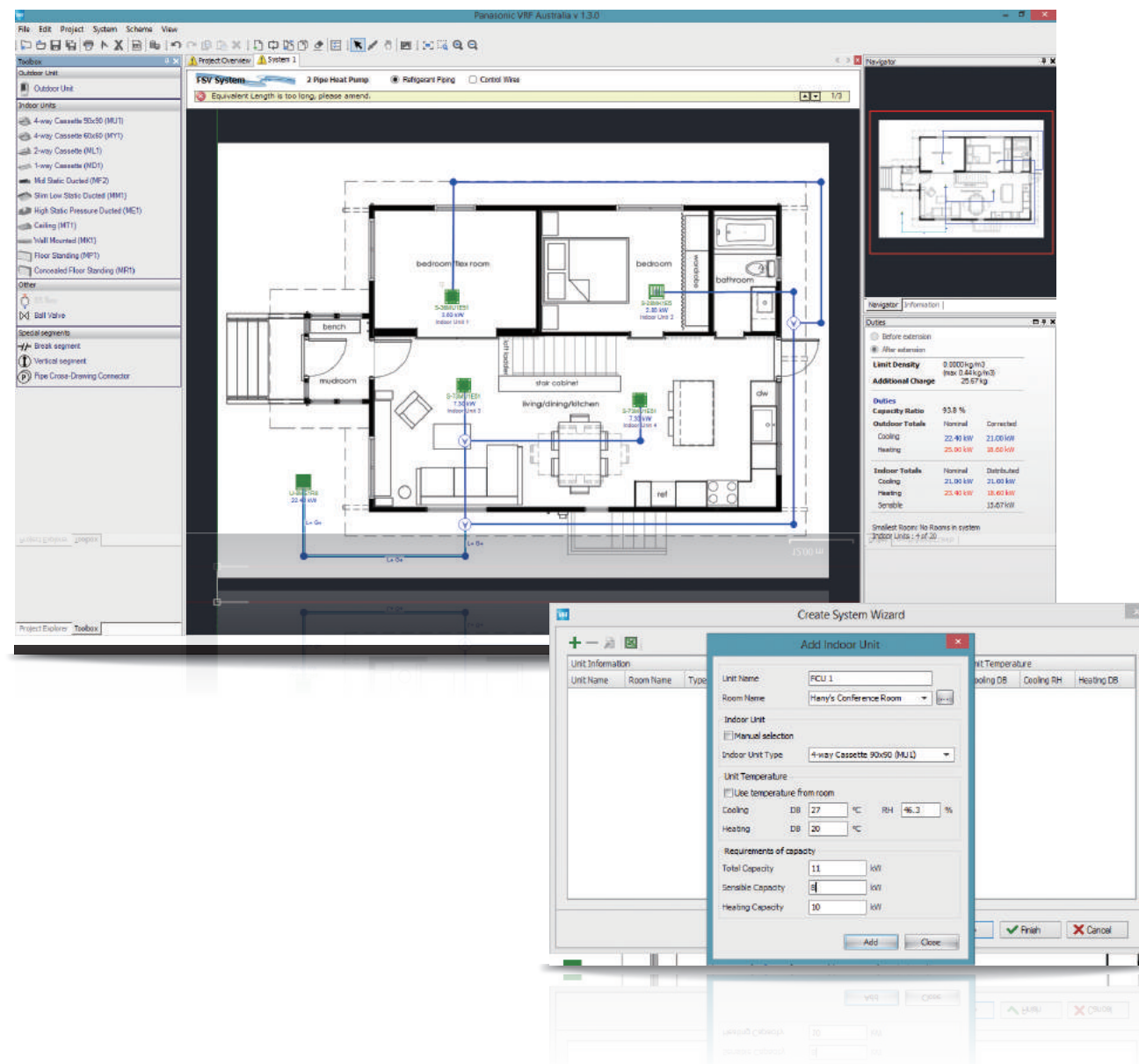

### Features include

- Mounting scheme  
Design selection from building floor drawing.
- Any kind of drawing format.  
(dxf, jpg, png..etc.)
- Conventional principal scheme.
- Easy to use system wizards.
- Auto piping and wiring features.
- Converted duties for conditions and pipework
- Auto(CAD) [dxf], Excel and PDF export.
- Detailed wiring and pipework diagrams.
- Automatic price quotation.
- Automatic tender document assist.



# New FSV Systems

FSV systems are designed for energy savings, high efficiency, and high durability with strong cooling power even operating at high ambient temperature. Panasonic continuously apply advanced technologies to meet the requirements of diverse situations and contribute to the creation of comfortable living spaces.

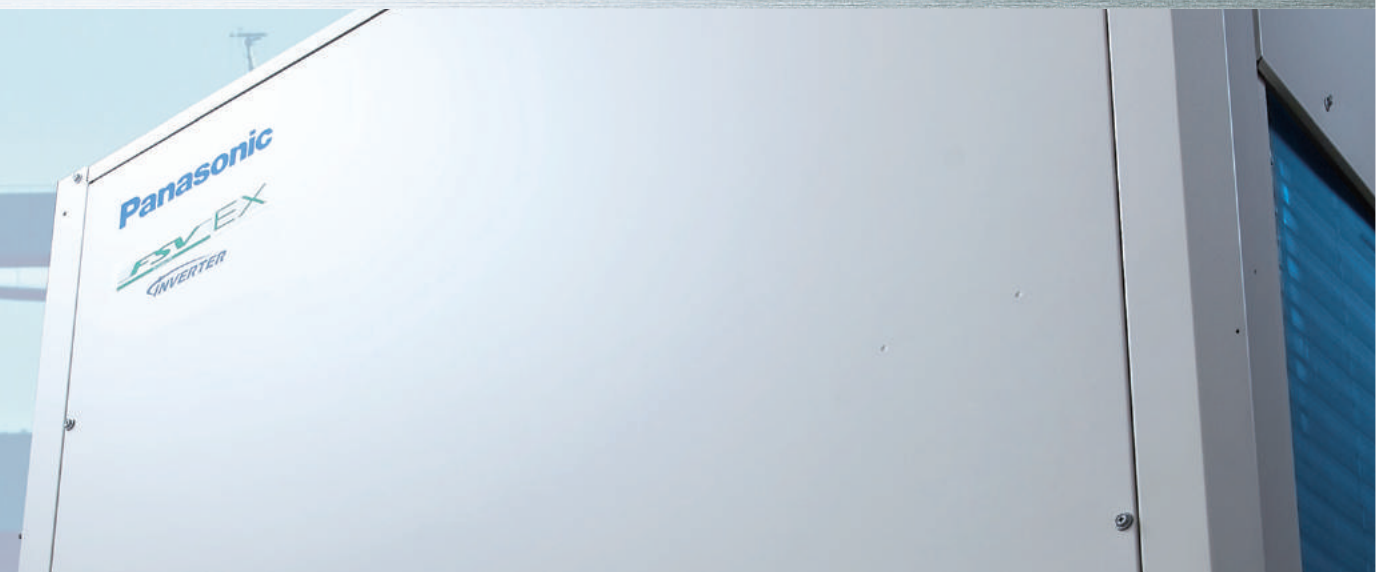

## 2-WAY FSV-EX ME2 Series **NEW**

Extraordinary energy-saving performance and powerful operation

### Space-saving Combination Model

Cooling or Heating Type

**New Hi-Durability Model**

- Wide range of systems from 8HP to 80HP
- Class-leading EER of 5.3 (for 8HP model)
- Industry-leading low noise of 53.0 DB (8HP model)
- Cooling operation possible with outdoor temperature as high as 52°C (DB)
- Long maximum pipe length (up to 1,000 m)
- Up to 64 indoor units connectable
- External static pressure of 80 Pa
- Extended operating range allows heating with outdoor temperatures as low as -25°C (WB)
- Suitable for R22 refurbishing projects

\* 66HP-80HP available from April 2016



### High Efficiency Combination Model

Cooling or Heating Type

**New Hi-Durability Model**

- Wide range of systems from 8HP to 64HP
- Class-leading EER of 5.3 (for 8HP model)
- Higher EER than the Space-saving Combination Model e.g., a combination of two 10HP units delivering 20HP reduces compressor load.



## 3-WAY FSV MF2 Series

For simultaneous heating and cooling operation

Heat Recovery Type

Cooling and Heating Simultaneous Type

- Wide range of systems from 8 HP to 42 HP
- Top class EER : 3.94 / COP : 4.49 (in the case of 8 HP)
- Longer max piping length (up to 500 m)
- Increased max number of connectable indoor units (up to 52)
- External static pressure increased to a high 80Pa
- Cooling operation is possible when outdoor temperature as high as 46°C DB
- Extended operating range to provide heating at outdoor temperature as low as -20°C WB
- Suitable for R22 renewal projects



## 2-WAY mini-FSV LE1 Series

For small-scale commercial and residential use

Industry Top Class EER/COP

Cooling or Heating Type 1 phase  
Cooling or Heating Type 3-phase

- Applicable to both single and three phase power supplies
- Top-class EER: 4.3 / COP: 4.62 (In case of 4 HP)
- Cooling operation is possible up to 46°C DB outdoor temperature
- Heating operation is possible when outdoor temperature as low as -20°C WB
- 9 units connectable to one outdoor unit (in the case of 6 HP)
- Piping length: 120m (Total piping length: 150m)



NEW

High-efficiency & Space-saving VRF system

# 2-WAY FSV-EX ME2

## Remarkable improvement on key components



## Extraordinary energy-saving performance

### 1 Multiple large-capacity all inverter compressors (more than 14HP)

Two independently controlled inverter compressors achieve high efficiency. Redesigned components in the body provide performance improvement especially in the rated cooling condition and EER performance.



### 2 Enlarged heat exchanger surface area with triple surface\*

The new heat exchanger features a triple-surface construction. Compared to the divided dual-surface construction in current models, there is no division of space and the area for heat exchange is larger. Also, highly efficient piping pattern increases heat exchange performance by 5%.



Conventional model [ME1]



New model [ME2]

\* For 8 & 10HP unit, the heat exchanger is 2 row design.

## Redesigned for smooth and better air discharge

### 3 Newly designed curved air discharge bell mouth for better aerodynamics

The new curved shape with integrated top and bottom assure smooth exhaust flow. This gives more air-volume with same sound level, less power input at same air-volume.

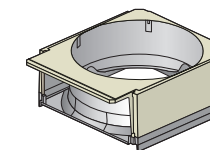

Conventional model [ME1]

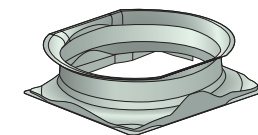

New model [ME2]

### 4 Large air discharge area with new flush surface top panel

To reduce air resistance, instead of a tubular fan design, a new large flat fan guard design, flush with the top panel, is employed. This design lead to the improvements in air resistance, but also contributed to better appearance designing.



Conventional model [ME1]



New model [ME2]

NEW

High-efficiency & Space-saving VRF system

# 2-WAY FSV-EX ME2

## A large number of indoor units can be connected

Up to 64 indoor units can be connected in a single system for ultimate design flexibility.

\*Maximum number of indoor units depends on outdoor unit capacity.

Up to 64 Indoor Units Connectable\*



## Increased piping length for greater design flexibility

Adaptable to various building types and sizes  
Actual piping length : 200m  
Max piping length : 1,000m

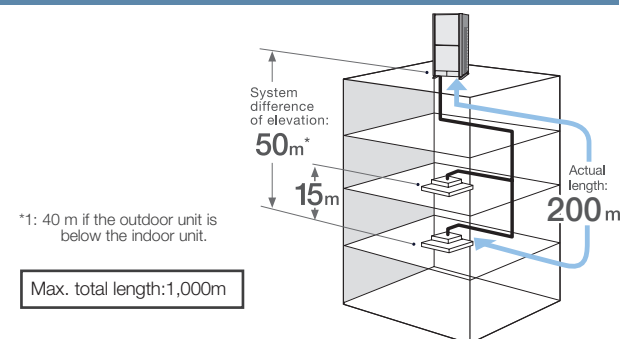

## Connectable indoor/outdoor unit capacity ratio up to 130% \*

FSV systems attain maximum indoor unit connection capacity of up to 130%\* of the unit's connection range, depending on the outdoor and indoor models selected. So for a reasonable investment, FSV systems provide an ideal air conditioning solution for locations where full cooling/heating are not always required.

SYSTEM / HP	8	10	12	14	16	18	20	22	24	26	28	30	32	34	36	38	40	42	44	46	48	50	52	54	56	58	60	62	64	66	68	70	72	74	76	78	80	
MNcIU : 130%	13	16	19	23	26	29	33	36	40	43	46	50	53	56	59	63	64	64	64	64	64	64	64	64	64	64	64	64	64	64	64	64	64	64	64	64	64	64

MNcIU : Maximum Number of Connectable Indoor Unit  
Note: If more than 100% indoor units are operated with a high load, the units may not perform at the rated capacity. For the details, please consult with an authorised Panasonic dealer

\* If the following conditions are satisfied, the effective range is above 130% up to 200%  
i) Obey the limited number of connectable indoor units.  
ii) The lower limit of operating range for heating outdoor temperature is limited to -10°CWB (standard -25°CWB).  
iii) Simultaneous operation is limited to less than 130% of connectable indoor units.

## Excellent energy savings

The operation efficiency has been improved using highly efficient R410A refrigerant, new DC inverter compressor, and new heat exchanger design.

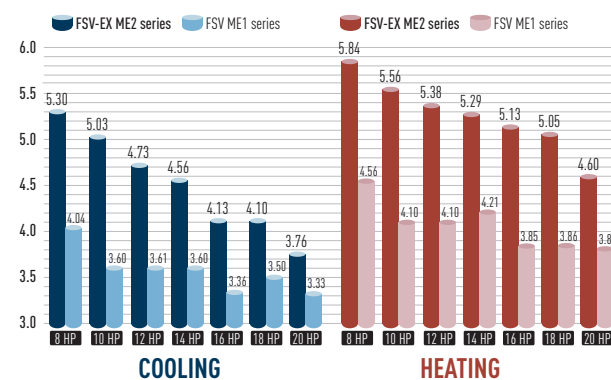

## Up to 50m length difference between the longest and the shortest piping from the first branch

Flexible piping layout makes it easier to design systems for locations such as train stations, airports, schools and hospitals.

- Up to 64 units can be connected to one system.
- Difference between maximum and minimum pipe runs after first branch can be a maximum of 50m.
- Larger pipe runs can be up to 200m.

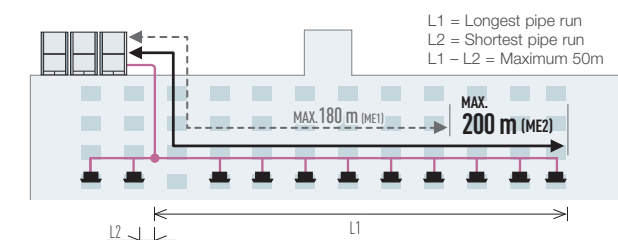

## Extended operating range

### Cooling operation range:

-10°C DB to +52°C DB

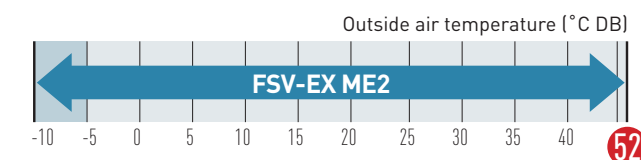

### Heating operation range:

Extended heating operation range enables heating even when the outdoor temperature is as low as -25°C. Using a wired remote control, indoor heating temperature range can be set from 16°C to 30°C\*.

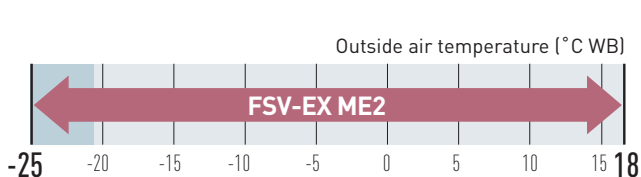

\* Depending on the type of remote controller.

## Compact design

The new ME2 series has reduced the installation space required with up to 20 HP available in a single chassis. 8 - 10 HP are able to fit inside a lift for easy handling on site.

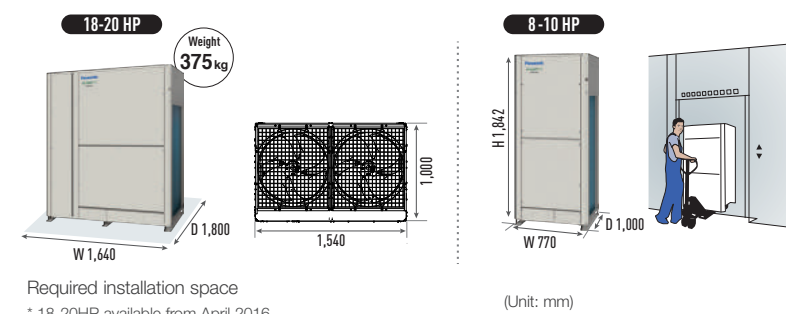

## Newly designed fan

### Optimised air flow

Newly designed fan and bell-mouth reduces stress on the fan by dispersing air quickly. Thus, lower air resistance results in lower energy consumption.

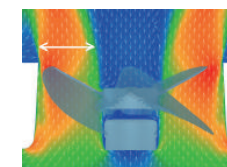

### Noise reduction

Turbulence (blue) can be suppressed and the unwanted noise can be reduced. Even though a high speed fan is utilised, the noise level is still very low.

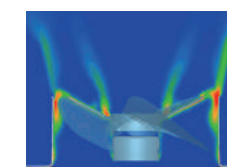



NEW

High-efficiency & Space-saving VRF system

# 2-WAY FSV-EX ME2

## High external static pressure on condensers

With a newly designed fan, fan guard, motor, and casing, new models can be custom-installed on-site to provide up to 80 Pa of external static pressure. An air discharge duct prevents shortages of air circulation, allowing outdoor units to be installed on every floor of a building.

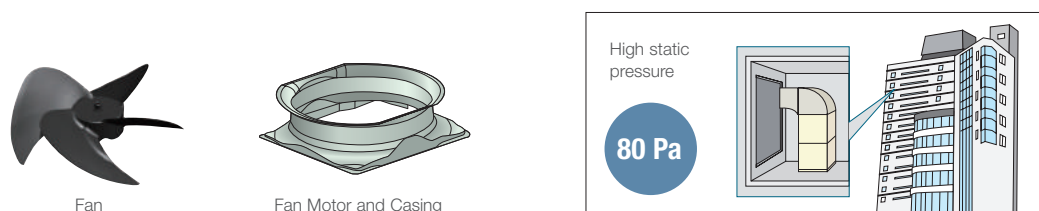

## Extended compressor life by uniform compressor operation time

The total run-time of compressors are monitored by a built-in microcomputer, which ensures that operation times of all compressors within the same refrigerant circuit are balanced.

Compressors with histories showing shorter run times are selected first, ensuring equal wear and tear across all units and extended the working life of the system.

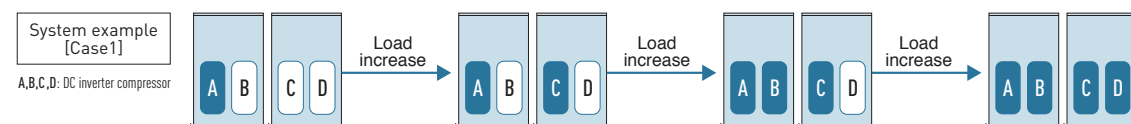

\* Depend on accumulated operation time of each compressors.  
 \* Compressor priority has possibility to be changed.  
 (e.g) Case1: A→C→B→D, Case2: C→A→D→B, Case3: A→C→D→B, Case4: C→A→B→D

## Automatic backup operation in the case of compressor failure or outdoor unit malfunction

### Except for 8, 10 & 12 HP single unit installation

\*Backup operation allows uninterrupted cooling or heating to continue whilst waiting for service. Users should contact their authorised service centre as soon as fault occurs.

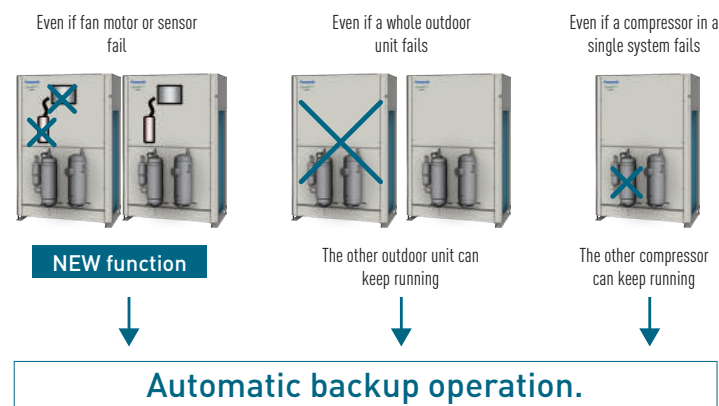

## Demand response

Featuring inverter control technology, all Panasonic FSV systems are Demand Response Management (DRM) ready. With this control, power consumption at times of peak load can be set in three steps to deliver optimum performance. This helps to reduce annual power consumption with minimal loss in comfort.

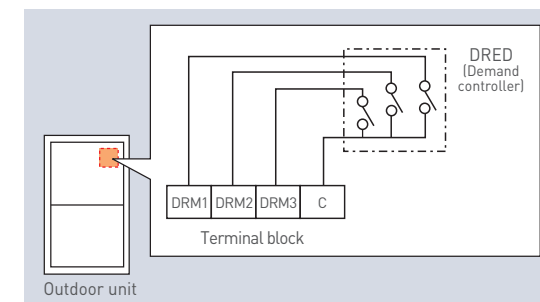

### Simple Demand Response with the CZ-CAPDC4

Demand control terminal is available to control 0-50-75-100% of capacities.

\*CZ-CAPDC4 is required as an option

Demand Response Signal	Power Input
DRM 1	0%
DRM 2	50%
DRM 3	100%

### Flexible Demand Response with the CZ-CAPDC2 \*1

Setting is possible as 0% or in the range from 40 to 100% (in steps of 5%). At the time of shipping, setting has been done to the three steps of 0%, 70% and 100%.

\*1 An outdoor Seri-Para I/O unit (CZ-CAPDC2) is required for demand input signal.

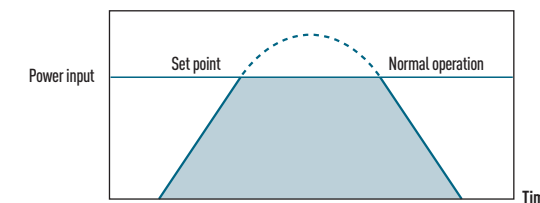

Level	Power input	Setting range
Level 1	100% (Preset)	Possible to change 40-100%
Level 2	70% (Preset)	
Level 3	0% (Always in stop condition)	

## Hi-durability outdoor unit

Corrosion-resistance treated for high resistance to rust and salty air to assure long-lasting performance.

Note: Selecting this unit does not completely eliminate the possibility of rust developing. For details concerning unit installation and maintenance, please consult an authorised dealer.

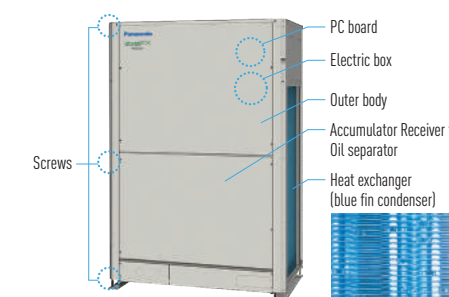





**NEW 2-WAY FSV-EX ME2 Series SPACE SAVING COMBINATION MODEL** (AVAILABLE 2016)



**8 / 10 HP**

According to the installation site, you may choose the setting position in the depth direction of the anchor bolt from A, B or C.

- A: (Installation hole pitch) For removing tube forward
- B: (Installation hole pitch) For removing the downward
- C: (Installation hole pitch)

Top view

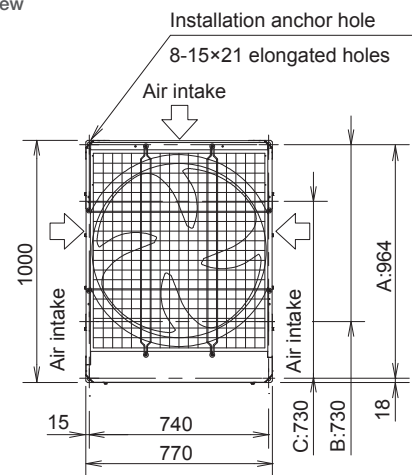

Front view

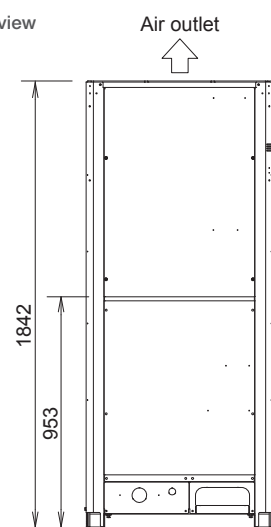

unit: mm

**12 / 14 / 16 HP**

According to the installation site, you may choose the setting position in the depth direction of the anchor bolt from A, B or C.

- A: (Installation hole pitch) For removing tube forward
- B: (Installation hole pitch) For removing the downward
- C: (Installation hole pitch)

Top view

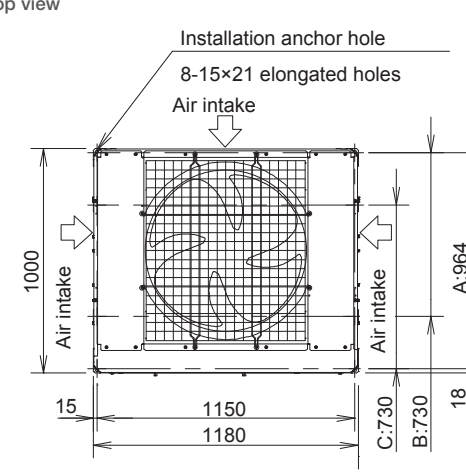

Front view

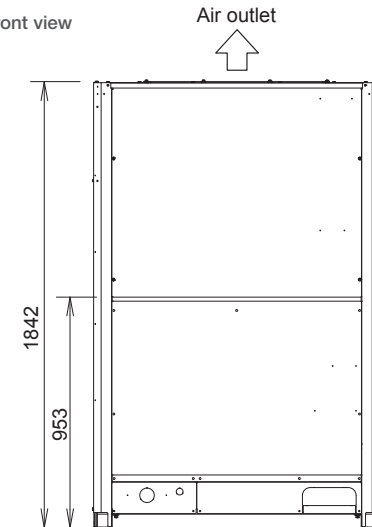

unit: mm

**18 / 20 HP**

According to the installation site, you may choose the setting position in the depth direction of the anchor bolt from A, B or C.

- A: (Installation hole pitch) For removing tube forward
- B: (Installation hole pitch) For removing the downward
- C: (Installation hole pitch)

Top view

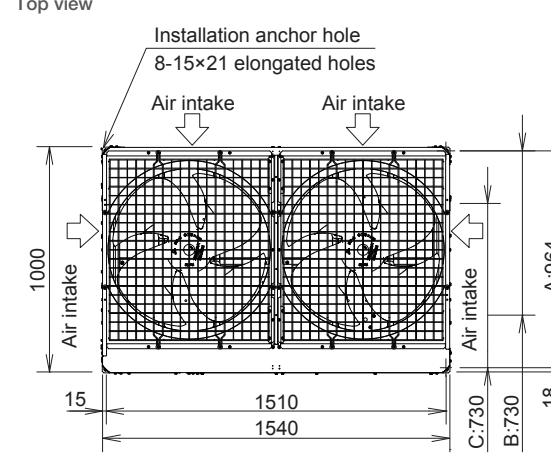

Front view

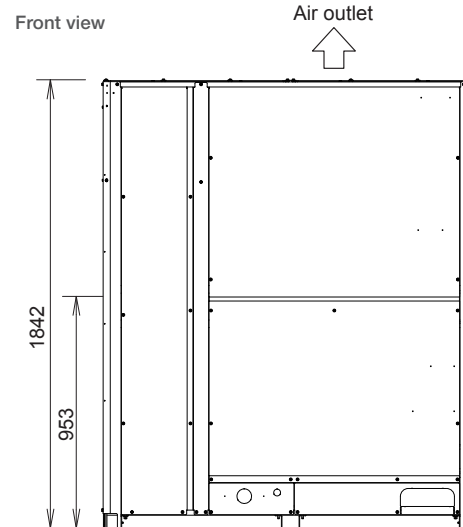

unit: mm

# Piping Design

Select installation locations so that the lengths and sizes of refrigerant piping are within the allowable ranges shown in the figure below.

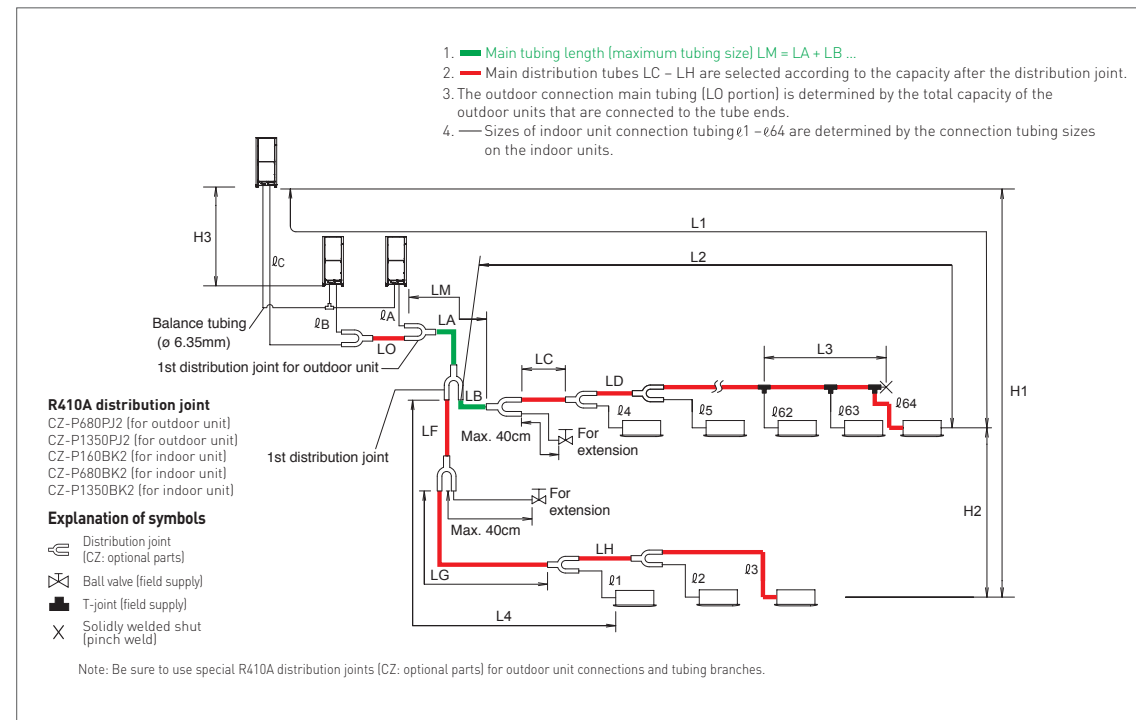

## Ranges that apply to refrigerant piping lengths and to differences in installation heights

Items	Mark	Contents	Length (m)
Allowable tubing length	L1	Max. tubing length	Actual length $\leq 200^{*2}$ Equivalent length $\leq 210^{*2}$
	$\Delta L$ (L2-L4)	Difference between max. length and min. length from the 1st distribution joint	$\leq 50^{*5}$
	LM	Max. length of main tubing (at maximum size) * Even after 1st distribution joint, LM is allowed if at maximum tubing length.	— <sup>*3</sup>
	$\phi 1, \phi 2 \sim \phi 64$	Max. length of each distribution tube	$\leq 30^{*7}$
	$L1 + \phi 1 + \phi 2 \sim \phi 63 + \phi A + \phi B + LF + LG + LH$	Total max. tubing length including length of each distribution tube (only liquid tubing)	$\leq 1000$
Allowable elevation difference	$\phi A, \phi B + LO, \phi C + LO$	Maximum tubing length from outdoor's 1st distribution joint to each outdoor unit	$\leq 10$
	H1	When outdoor unit is installed higher than indoor unit	$\leq 50$
	H2	When outdoor unit is installed lower than indoor unit	$\leq 40$
Allowable length of joint tubing	H3	Max. difference between indoor units	$\leq 15^{*6}$
	H3	Max. difference between outdoor units	$\leq 4$
Allowable length of joint tubing	L3	T-joint tubing (field-supply); Max. tubing length between the first T-joint and solidly welded-shut end point	$\leq 2$

L = Length, H = Height

**NOTE**

- The outdoor connection main tubing (LO portion) is determined by the total capacity of the outdoor units that are connected to the tube ends.
- If the longest tubing length (L1) exceeds 90 m (equivalent length), increase the sizes of the main tubes (LM) by 1 rank for gas tubes and liquid tubes. Use a field supply reducer. Select the tube size from the table of main tubing sizes (Table 3) and from the table of refrigerant tubing sizes (Table 8) on the second following page.
- If the longest main tubing length (LM) exceeds 50 m, increase the main tubing size at the portion before 50 m by 1 rank for the gas tubes. Use a field supply reducer. Determine the length less than the limitation of allowable maximum tubing length. For the portion that exceeds 50 m, set based on the main tubing size (LA) listed in Table 3.
- If the size of the existing tubing is already larger than the standard tubing size, it is not necessary to further increase the size.
- If the existing tubing is used, and the amount of on-site refrigerant charge exceeds the value listed below, then change the size of the tubing to reduce the amount of refrigerant.  
 Total amount of refrigerant for the system with 1 outdoor unit: 50 kg  
 Total amount of refrigerant for the system with 2 outdoor units: 80 kg  
 Total amount of refrigerant for the system with 3 outdoor units or 4 outdoor units: 105 kg
- When the tubing length exceeds 40 m, increase a longer liquid or gas tubing by 1 rank. Refer to the Technical Data for the details.
- If the total distribution tubing length exceeds 500m, maximum allowable elevation difference (H2) between the indoor units is calculated by the following formula. Make sure the indoor unit's actual elevation difference should fall within the figure calculated as follows.  
 Unit of account (meter):  $15 \times (2 - \text{total tubing length(m)} \div 500)$
- If any of the tubing length exceeds 30m, increase the size of the liquid and gas tubes by 1 rank.

## Necessary amount of additional refrigerant charge per outdoor unit

U-8ME2H7	U-10ME2H7	U-12ME2H7	U-14ME2H7	U-16ME2H7
0 kg	0 kg	4.0 kg	4.0 kg	4.0 kg

## System limitations

Max. No. allowable connected outdoor units	4 <sup>*2</sup>
Max. capacity allowable connected outdoor units	180 kW (64 HP)
Max. connectable indoor units	64 <sup>*1</sup>
Max. allowable indoor/outdoor capacity ratio	50-130 % <sup>*3</sup>

- <sup>\*1</sup>: In the case of 38 HP or smaller units, the number is limited by the total capacity of the connected indoor units.  
<sup>\*2</sup>: Up to 4 units can be connected if the system has been extended.  
<sup>\*3</sup>: If the following conditions are satisfied, the effective range is above 130 % and below 200 %.  
 i) Obey the limited number of connectable indoor units.  
 ii) The lower limit of operating range for heating outdoor temperature is limited to -10°CWB (standard -25°CWB).  
 iii) Simultaneous operation is limited to less than 130 % of connectable indoor units.

## Additional refrigerant charge

Liquid tubing size mm (inches)	Amount of refrigerant charge/m (g/m)
$\phi 6.35$ ( $\phi 1/4$ )	26
$\phi 9.52$ ( $\phi 3/8$ )	56
$\phi 12.7$ ( $\phi 1/2$ )	128
$\phi 15.88$ ( $\phi 5/8$ )	185
$\phi 19.05$ ( $\phi 3/4$ )	259
$\phi 22.22$ ( $\phi 7/8$ )	366
$\phi 25.4$ ( $\phi 1$ )	490

## Refrigerant piping (Existing piping can be used.)

Tubing size (mm)			
Material Temper - O		Material Temper - 1/2 H, H	
$\phi 6.35$	t 0.8	$\phi 22.22$	t 1.0
$\phi 9.52$	t 0.8	$\phi 25.4$	t 1.0
$\phi 12.7$	t 0.8	$\phi 28.58$	t 1.0
$\phi 15.88$	t 1.0	$\phi 31.75$	t 1.1
$\phi 19.05$	t 1.2	$\phi 38.1$	over t 1.35
		$\phi 41.28$	over t 1.45
		$\phi 44.45$	over t 1.55

\* When bending the tubes, use a bending radius that is at least 4 times the outer diameter of the tubes. In addition, take sufficient care to avoid crushing or damaging the tubes when bending them.



# Refrigerant Branch Pipes (optional accessories) for 2-WAY ME2 Series

## Optional Distribution Joint Kits

See the installation instructions packaged with the distribution joint kit for the installation procedure.

\* In case the total capacity of indoor units connected after distribution exceeds the total capacity of the outdoor units, select the distribution tubing size for the total capacity of the outdoor units.

Model name	Cooling capacity after distribution	Remarks
1. CZ-P680PJ2	68.0 kW or less	For outdoor unit
2. CZ-P1350PJ2	more than 68.0 kW	For outdoor unit
3. CZ-P160BK2	22.4 kW or less *	For indoor unit
4. CZ-P680BK2	68.0 kW or less *	For indoor unit
5. CZ-P1350BK2	more than 68.0 kW *	For indoor unit

## Tubing size (with thermal insulation)

### 1. CZ-P680PJ2

For outdoor unit (Capacity after distribution joint is 68.0 kW or less.)

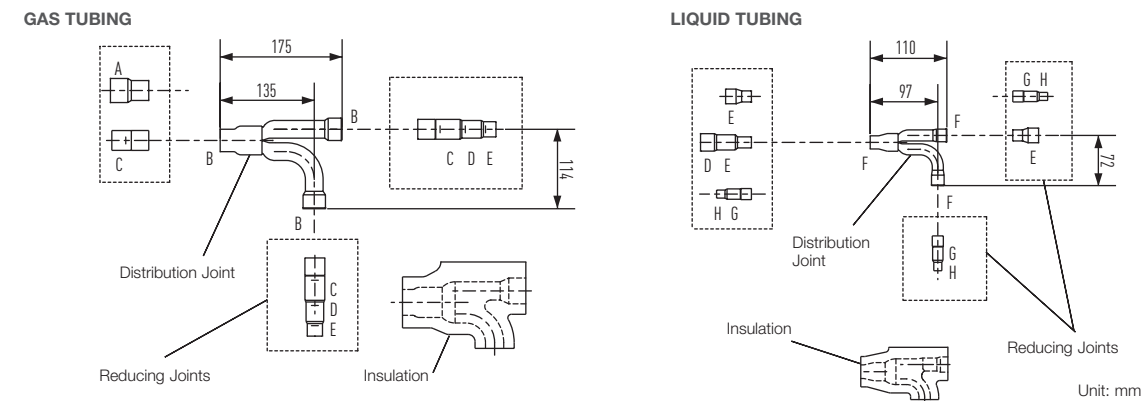

Size	Part A	Part B	Part C	Part D	Part E	Part F	Part G	Part H
Dimension (mm)	ø31.75	ø28.58	ø25.40	ø22.22	ø19.05	ø15.88	ø12.70	ø9.52
Dimension (inches)	Ø1-1/4	Ø1-1/8	Ø1	Ø7/8	Ø3/4	Ø5/8	Ø1/2	Ø3/8

### 2. CZ-P1350PJ2

For outdoor unit (Capacity after distribution joint is more than 68.0 kW.)

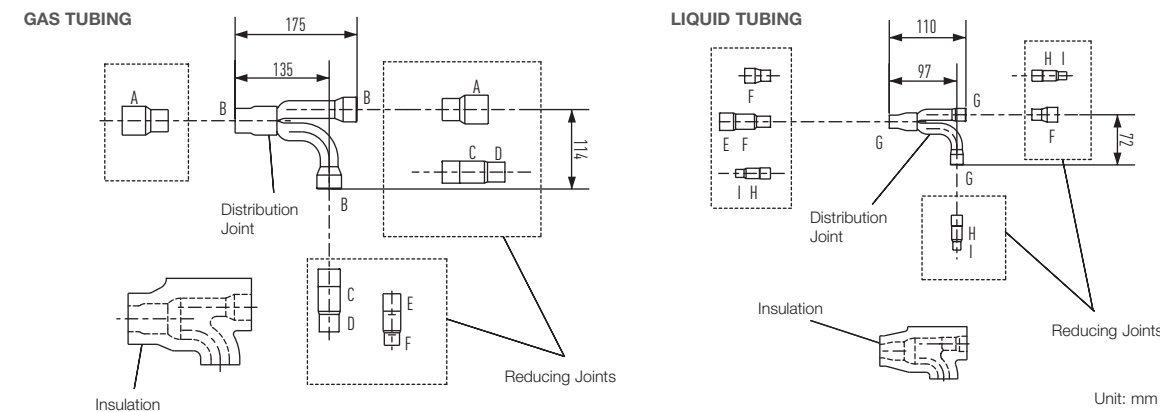

Size	Part A	Part B	Part C	Part D	Part E	Part F	Part G	Part H	Part I
Dimension (mm)	ø38.10	ø31.75	ø28.58	ø25.40	ø22.22	ø19.05	ø15.88	ø12.70	ø9.52
Dimension (inches)	Ø1-1/2	Ø1-1/4	Ø1-1/8	Ø1	Ø7/8	Ø3/4	Ø5/8	Ø1/2	Ø3/8

\* If the tube diameter is more than ø38.1, use field-supply reducer.

### 3. CZ-P160BK2

Use: For indoor unit (Capacity after distribution joint is 22.4 kW or less.)\*

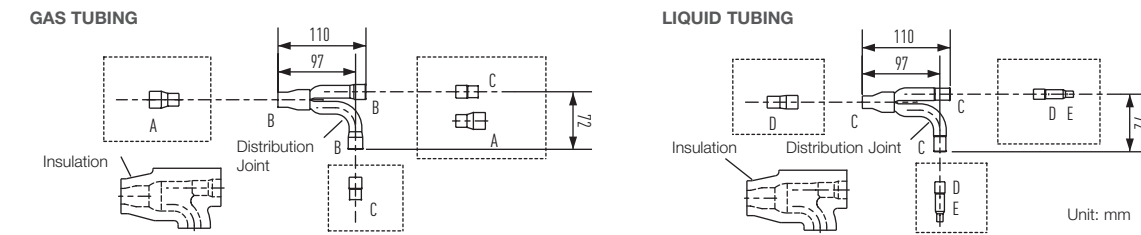

Size	Part A	Part B	Part C	Part D	Part E
Dimension (mm)	Ø19.05	Ø15.88	Ø12.70	Ø9.52	Ø6.35
Dimension (inches)	Ø3/4	Ø5/8	Ø1/2	Ø3/8	Ø1/4

### 4. CZ-P680BK2

Use: For indoor unit (Capacity after distribution joint is more than 22.4 kW and no more than 68.0 kW.)\*

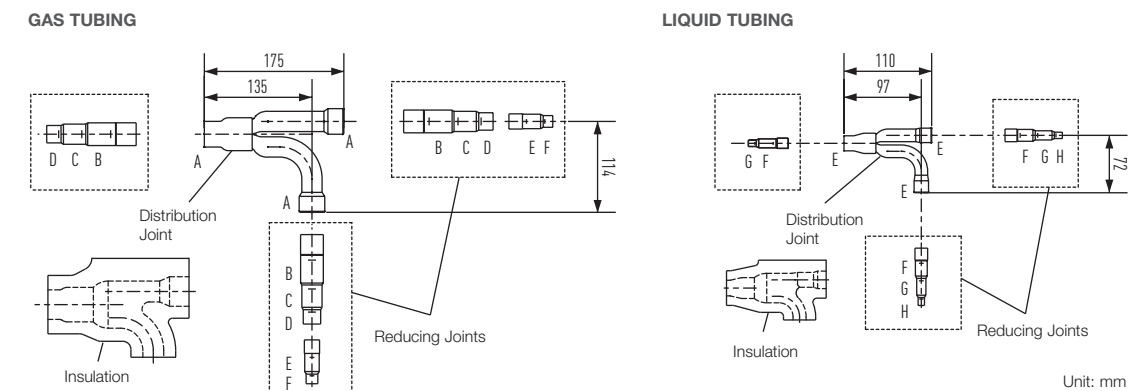

Size	Part A	Part B	Part C	Part D	Part E	Part F	Part G	Part H
Dimension (mm)	Ø28.58	Ø25.40	Ø22.22	Ø19.05	Ø15.88	Ø12.70	Ø9.52	Ø6.35
Dimension (inches)	Ø1-1/8	Ø1	Ø7/8	Ø3/4	Ø5/8	Ø1/2	Ø3/8	Ø1/4

### 5. CZ-P1350BK2

Use: For indoor unit (Capacity after distribution joint is more than 68.0 kW.)\*

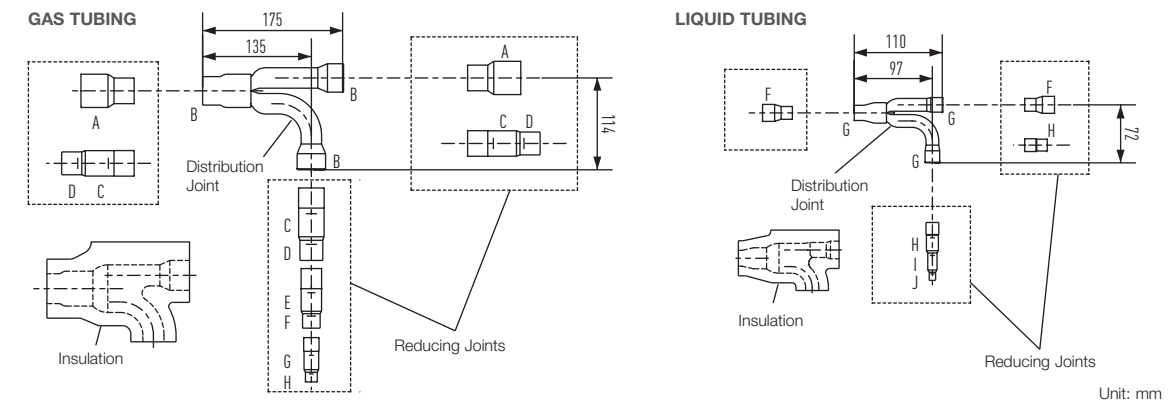

Size	Part A	Part B	Part C	Part D	Part E	Part F	Part G	Part H	Part I	Part J
Dimension (mm)	Ø38.10	Ø31.75	Ø28.58	Ø25.40	Ø22.22	Ø19.05	Ø15.88	Ø12.70	Ø9.52	Ø6.35
Dimension (inches)	Ø1-1/2	Ø1-1/4	Ø1-1/8	Ø1	Ø7/8	Ø3/4	Ø5/8	Ø1/2	Ø3/8	Ø1/4

\* If the tube diameter is more than ø38.1, use field-supply reducer.

\* In case the total capacity of indoor units connected after distribution exceeds the total capacity of the outdoor units, select the distribution tubing size for the total capacity of the outdoor units.

# INVERTER

For small-scale commercial and residential use

## 2-WAY mini-FSV LE1 Series

COOLING OR HEATING TYPE 1 PHASE  
COOLING OR HEATING TYPE 3-PHASE

Panasonic 2-WAY mini FSV, is a 2-pipe heat pump specifically designed for the most demanding applications. Mini FSV is available in 3 sizes with cooling / heating capacities ranging from 4 HP to 6 HP with up to 9 indoor units connectable (applicable for 6 HP).



- Top-class EER:4.30 / COP:4.62 (In the case of 4HP)
- Cooling operation is possible when outdoor temperature is as high as 46°C DB
- Maximum number of connectable indoor units : 4HP:6 5HP:8 6HP:9
- Diversity ratio 50-130%
- DC inverter technology combined with R410A for excellent efficiency
- Actual piping length:120m (Total piping length:150m)
- System difference of elevation:50m /40m (outdoor above/below)
- Demand response ready (Peak cut)
- Difference in elevation between indoor units:15m
- Cooling operation is possible when outdoor temperature as low as -10°C DB
- Heating operation is possible when outdoor temperature as low as -20°C WB
- Compact outdoor unit 1,330 x 940 x 340 mm
- One ampere starting current
- Full range of indoor units and control options
- Auto restart from outdoor unit
- Hi-durability outdoor unit



### Energy-saving concept.

The use of energy saving designs for the structure of fans, fan motors, compressors and heat exchangers results in high COP values which rank among the top class in the industry. In addition, use of highly efficient R410A refrigerant reduces CO2 emissions and lowers operating costs.



- 1 Panasonic Inverter Compressor** A large-capacity inverter compressor has been adopted. The inverter compressor is superior in performance with improved partial-load capacity.
- 2 Printed Circuit Board** The number of PCB was reduced from 3 into 2 pieces making maintenance easier.
- 3 Accumulator** A large accumulator has been adopted to maintain compressor reliability because of the increased refrigerant quantity, which allows an extended max piping length. Furthermore, refrigerant pressure loss is reduced, which contributes to an improved operating efficiency.
- 4 DC Fan Motor** Checking load and outside temperature, the DC motor is controlled for optimum air volume.
- 5 Newly designed fan** The newly designed fan blades have been developed to inhibit air turbulence and to increase efficiency. As fan diameter has been increased to 490mm, the air volume has been increased by 12% whilst maintaining a low sound level.
- 6 Heat Exchanger & Copper Tubes** The heat exchanger size and the copper tube sizes in the heat exchanger have been redesigned to increase efficiency.
- 7 Oil Separator** A new centrifugal separator has been adopted to improve oil separation efficiency and reduce refrigerant pressure loss.

## 2-WAY mini-FSV LE1 Series

### System example

An expansion from Panasonic VRF line up, the mini FSV is compatible with the same indoor units and controls as the rest of the FSV range.

4 - 6 HP

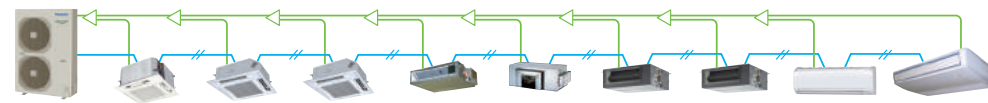

SYSTEM / HP	4 HP	5 HP	6 HP
Connectable Indoor Unit	6	8	9

### Wide operating range

- Cooling operation is possible when outdoor temperature as low as -10°C DB
  - Cooling operation is possible when outdoor temperature as high as 46°C DB
  - Heating operation is possible when outdoor temperature as low as -20°C WB
- The remote controller temperature can be set from 16°C up to 30°C\*.

4 - 6 HP

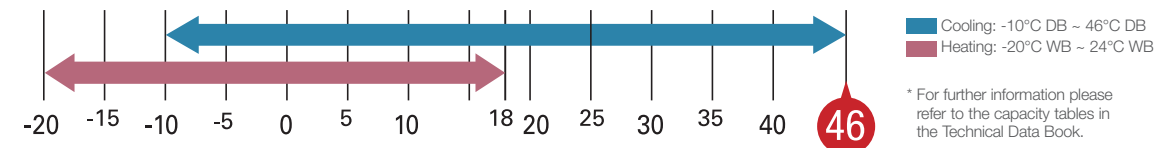

\* Depending on the type of remote controller.

### Improved energy savings

The operation efficiency has been improved using highly efficient R410A refrigerant, new DC Inverter compressor, new DC motor and a new heat exchanger design.

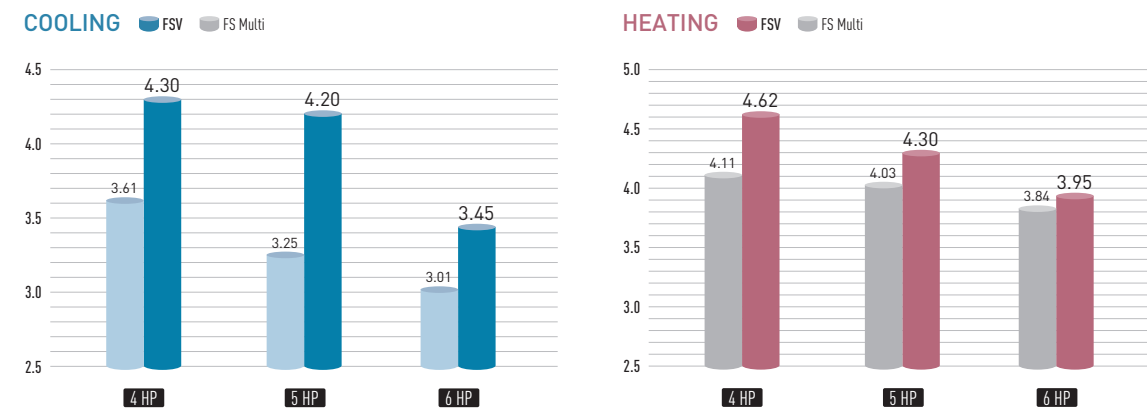

### Demand response

Featuring inverter control technology, all Panasonic FSV systems are Demand Response Management (DRM) ready. With this control, power consumption at times of peak load can be set in three steps to deliver optimum performance. This helps to reduce annual power consumption with minimal loss in comfort.

#### Simple Demand Response with the CZ-CAPDC3

Demand control terminal is available to control 0-50-75-100% of capacities.

\* CZ-CAPDC3 is required as an option

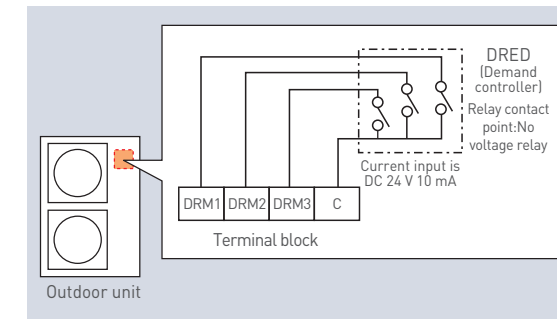

Demand Response Signal	Power Input
DRM 1	0%
DRM 2	50%
DRM 3	100%

#### Flexible Demand Response with the CZ-CAPDC2\*1

Setting is possible as 0% or in the range from 40 to 100% (in steps of 5%). At the time of shipping, setting has been done to the three steps of 0%, 70% and 100%.

\*1 An outdoor Seri-Para I/O unit (CZ-CAPDC2) is required for demand input signal.

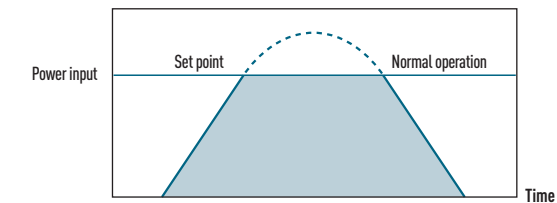

	Power input	
Level 1	100% (Preset)	Possible to change 40-100%
Level 2	70% (Preset)	
Level 3	0% (Always in stop condition)	

### Hi-durability outdoor unit

Corrosion-resistance treated for high resistance to rust and salty air to assure long-lasting performance.

Note: Selecting this unit does not completely eliminate the possibility of rust developing. For details concerning unit installation and maintenance, please consult an authorised dealer.

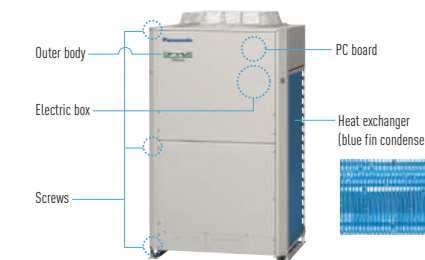



## 2-WAY mini-FSV LE1 Series

### Increased piping length for greater design flexibility

Adaptable to various building types and sizes  
 Actual piping length : 120m  
 (equivalent piping length 140m)  
 Max. piping length : 150m

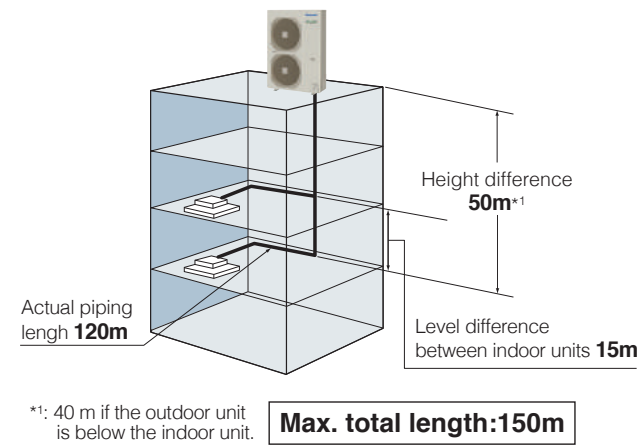

### Compact & flexible design

The slim and lightweight design can be installed in various places.

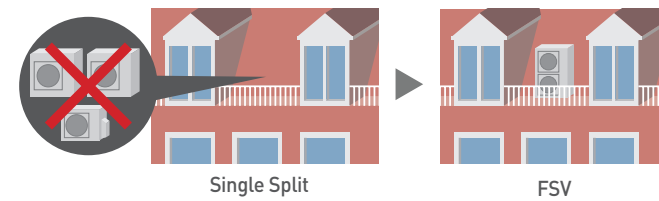

### Silent mode

Silent mode reduces outdoor unit operating sound up to 5dB.  
 External input signal is also available.



HP			4		5		6		
Model name			U-4LE1H4	U-4LE1H7	U-5LE1H4	U-5LE1H7	U-6LE1H4	U-6LE1H7	
Power supply	(50/60Hz)		220/230/240V/1-phase/50Hz 220/230V/1-phase/60Hz	380/400/415V/3-phase/50Hz 380/400V/3-phase/60Hz	220/230/240V/1-phase/50Hz 220/230V/1-phase/60Hz	380/400/415V/3-phase/50Hz 380/400V/3-phase/60Hz	220/230/240V/1-phase/50Hz 220/230V/1-phase/60Hz	380/400/415V/3-phase/50Hz 380/400V/3-phase/60Hz	
Capacity	Cooling	kW	12.10	12.10	14.00	14.00	15.50	15.50	
		BTU/h	41,300	41,300	47,800	47,800	52,900	52,900	
	Heating	kW	12.50	12.50	16.00	16.00	18.00	18.00	
		BTU/h	42,700	42,700	54,600	54,600	61,400	61,400	
EER/COOP	Cooling	W/W	4.30	4.30	4.20	4.20	3.45	3.45	
	Heating	W/W	4.62	4.62	4.30	4.30	3.95	3.95	
Dimensions (H/W/D)	mm		1,330 x 940 x 340 (410*)	1,330 x 940 x 340 (410*)	1,330 x 940 x 340 (410*)	1,330 x 940 x 340 (410*)	1,330 x 940 x 340 (410*)	1,330 x 940 x 340 (410*)	
Net weight	kg		104	103	104	103	104	103	
Electrical ratings	Cooling	Running current	A	13.9/13.3/12.7	4.9/4.7/4.5	16.3/15.6/14.9	5.7/5.4/5.2	21.5/20.5/19.7	7.5/7.1/6.9
		Power input	kW	2.81	2.81	3.33	3.33	4.49	4.49
	Heating	Running current	A	13.2/12.7/12.1	4.7/4.5/4.3	18.0/17.2/16.5	6.3/6.0/5.8	21.6/20.7/19.8	7.5/7.2/6.9
		Power input	kW	2.71	2.71	3.72	3.72	4.56	4.56
Starting current	A		1/1/1	1/1/1	1/1/1	1/1/1	1/1/1	1/1/1	
Air flow rate		m <sup>3</sup> /min	95	95	104	104	104	104	
		L/s	1,583	1,583	1,733	1,733	1,733	1,733	
Refrigerant amount at shipment	kg		R410A 3.50	R410A 3.50	R410A 3.50	R410A 3.50	R410A 3.50	R410A 3.50	
Piping connection	Gas pipe	mm (inches)	Ø15.88 (Ø5/8)	Ø15.88 (Ø5/8)	Ø15.88 (Ø5/8)	Ø15.88 (Ø5/8)	Ø19.05 (Ø3/4)	Ø19.05 (Ø3/4)	
	Liquid pipe	mm (inches)	Ø9.52 (Ø3/8)	Ø9.52 (Ø3/8)	Ø9.52 (Ø3/8)	Ø9.52 (Ø3/8)	Ø9.52 (Ø3/8)	Ø9.52 (Ø3/8)	
Ambient temperature operating range			Cooling: -10°CDB~+46°CDB, Heating: -20°CWB~+18°CWB	Cooling: -10°CDB~+46°CDB, Heating: -20°CWB~+18°CWB	Cooling: -10°CDB~+46°CDB, Heating: -20°CWB~+18°CWB	Cooling: -10°CDB~+46°CDB, Heating: -20°CWB~+18°CWB	Cooling: -10°CDB~+46°CDB, Heating: -20°CWB~+18°CWB	Cooling: -10°CDB~+46°CDB, Heating: -20°CDB~+24°CDB	
	Sound pressure level	Normal mode	dB(A)	50/52: Cooling/Heating	52/55: Cooling/Heating	51/53: Cooling/Heating	51/53: Cooling/Heating	52/55: Cooling/Heating	52/55: Cooling/Heating
		Silent mode	dB(A)	47/49: Cooling/Heating	47/49: Cooling/Heating	48/50: Cooling/Heating	48/50: Cooling/Heating	49/52: Cooling/Heating	49/52: Cooling/Heating
Sound power level	Normal mode	dB(A)	68/70: Cooling/Heating	68/70: Cooling/Heating	69/71: Cooling/Heating	69/71: Cooling/Heating	70/73: Cooling/Heating	70/73: Cooling/Heating	
GLOBAL REMARKS	Rated conditions:		Cooling	Heating	* As a foot print.				
	Indoor air temperature		27°C DB / 19°C WB	20°C DB					
	Outdoor air temperature		35°C DB	7°C DB / 6°C WB					

### Dimensions

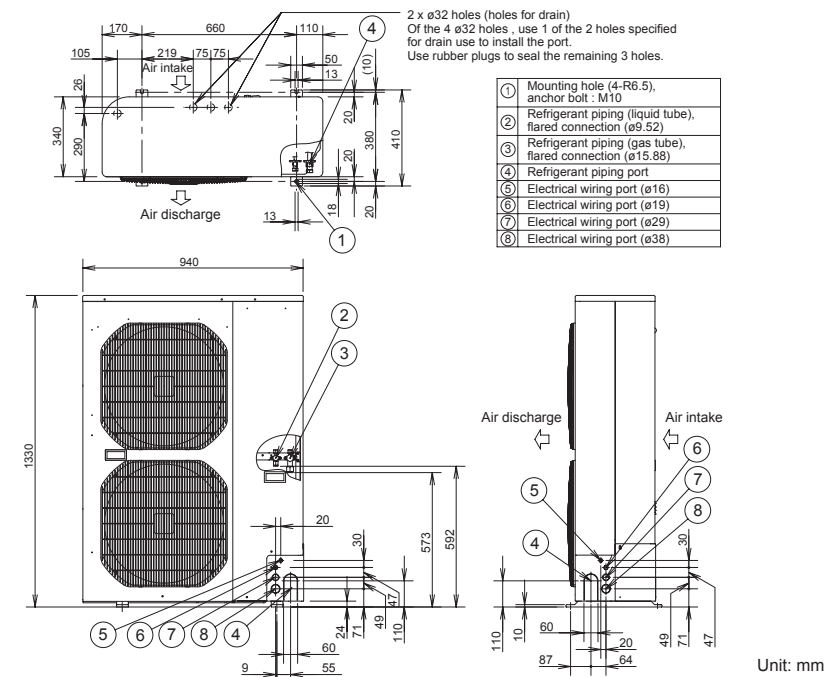

Distribution Joint Kits

CZ-P160BK2

Use: For indoor unit (Capacity after distribution joint is 22.4 kW or less.)

GAS TUBING

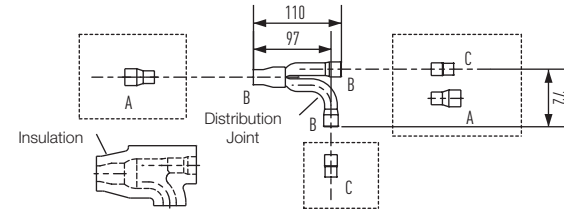

LIQUID TUBING

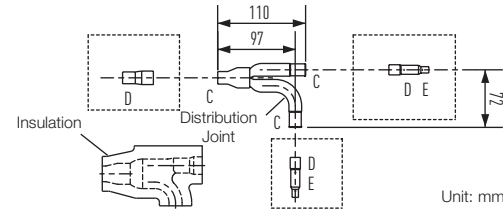

Unit: mm

Size of connection point on each part (Shown are inside diameters of tubing)

Size	Part A	Part B	Part C	Part D	Part E
Dimension (mm)	Ø19.05	Ø15.88	Ø12.70	Ø9.52	Ø6.35
Dimension (inches)	Ø3/4	Ø5/8	Ø1/2	Ø3/8	Ø1/4

Wiring System Diagrams

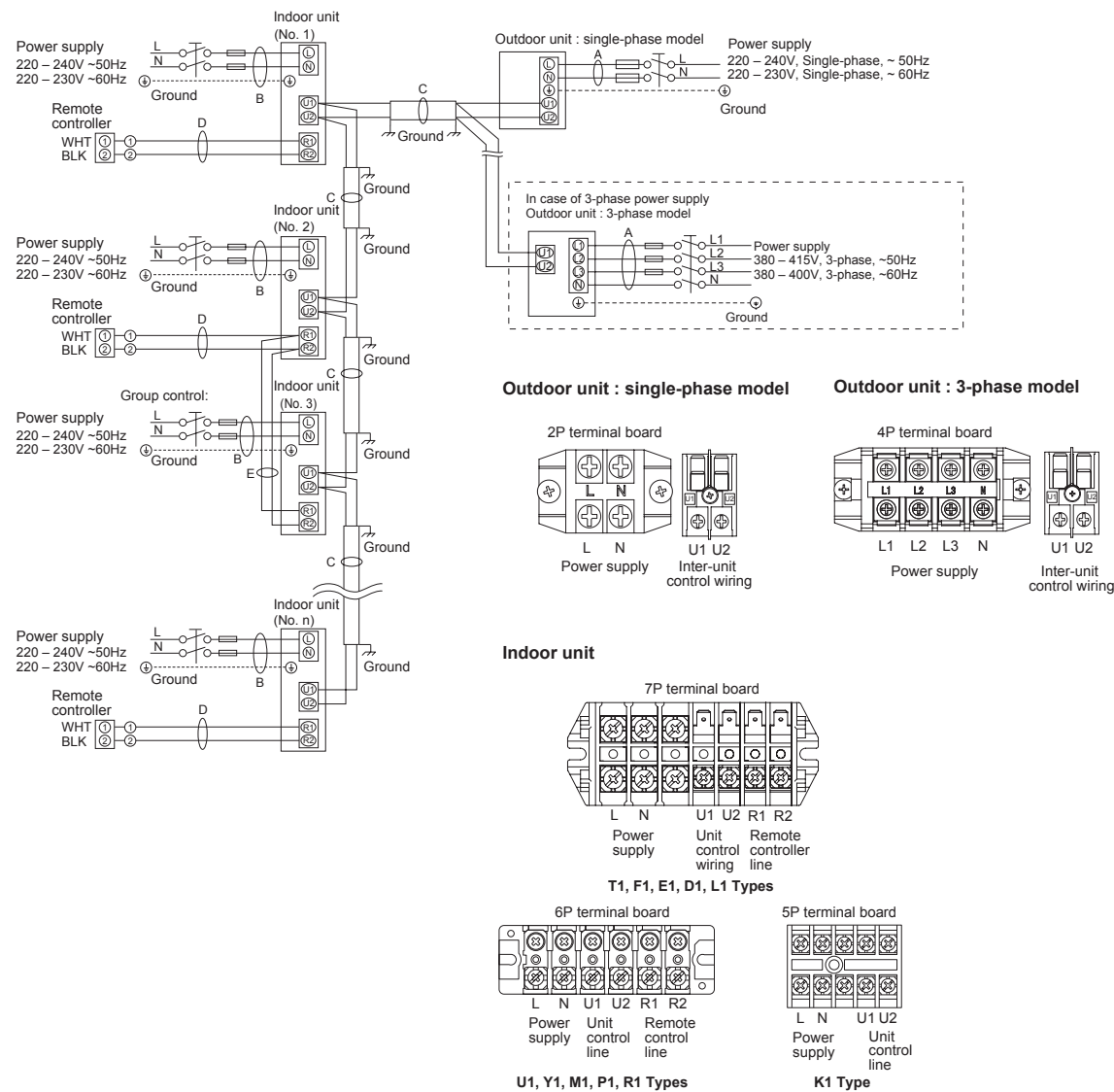
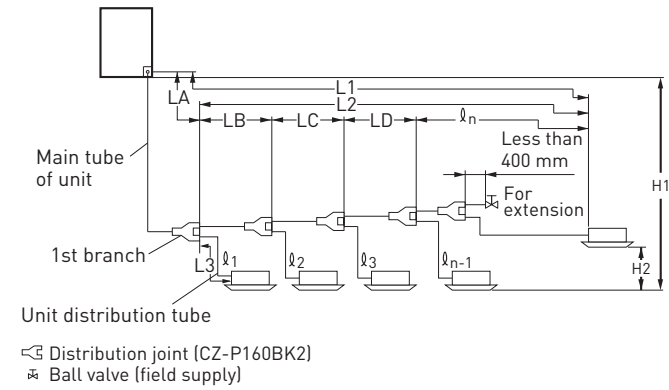

Fig. 2-1

Piping design

Select the installation location so that the length and size of refrigerant piping are within the allowable range shown in the figure below.



Ranges that Apply to Refrigerant Piping Lengths and to Differences in Installation Heights

Items	Marks	Contents	Length (m)	
			Actual length	Equivalent length
Allowable tubing length	L1	Max. tubing length	120	140
	$\Delta L (L2 - L3)$	Difference between max. length and min. length from the No.1 distribution joint	40	
	$l_1, l_2, \dots, l_n$	Max. length of each distribution tube	30	
	$l_1, l_2, \dots, l_{n-1} + l_1$	Total max. tubing length including length of each distribution tube (only narrow tubing)	150	
Allowable elevation difference	H1	When outdoor unit is installed higher than indoor unit	50	
	H2	When outdoor unit is installed lower than indoor unit	40	
		Max. difference between indoor units	15	

L = Length, H = Height

Tubing Size

Main Tubing Size (LA)

	12.1 kW	14.0 kW	15.5 kW
System kilowatts	12.1	14.0	15.5
Gas tubing mm (inches)	Ø15.88 (Ø5/8)		Ø19.05 (Ø3/4)
Liquid tubing mm (inches)	Ø9.52 (Ø3/8)		

Note :If the system consists of only one indoor unit with an outdoor 6HP, the main tube of the unit (LA) should be Ø19.05. Convert Ø19.05 to Ø15.88 using a reducer (field supply) close to the indoor unit and then make the connection.

Main Tubing Size After Distribution (LB, LC...)

Total capacity after distribution	Below kW	7.1	12.1	14.0	15.5
	Over kW	7.1			
Tubing size	Gas tubing	(mm) Ø12.7	Ø15.88	Ø19.05	
		(inches) Ø1/2	Ø5/8	Ø3/4	
	Liquid tubing	(mm) Ø9.52	Ø3/8		
		(inches) Ø3/8			

kW = kilowatts

Note :In case the total capacity of connected indoor units exceeds the total capacity of the outdoor units, select the main tubing size for the total capacity of the outdoor units.

Indoor Unit Tubing Connection (l1, l2...ln-1)

Indoor unite type	22	28	36	45	56	73	90	106	140	160
Gas tubing mm (inches)	Ø12.7 (Ø1/2)					Ø15.88 (Ø5/8)				
Liquid tubing mm (inches)	Ø6.35 (Ø1/4)					Ø9.52 (Ø3/8)				

System Limitations

Outdoor units	12.1 kW	14.0 kW	15.5 kW
Number of max. connectable indoor units	6	8	9
Max. allowable indoor/outdoor capacity ratio	50 - 130%		

kW = kilowatts



Simultaneous heating and cooling VRF system

# 3-WAY FSV MF2 Series

Heat Recovery Type



## New 3-WAY FSV MF2 series enables simultaneous heating and cooling operation

- Suitable for R22 renewal projects (Refer to Page 126)

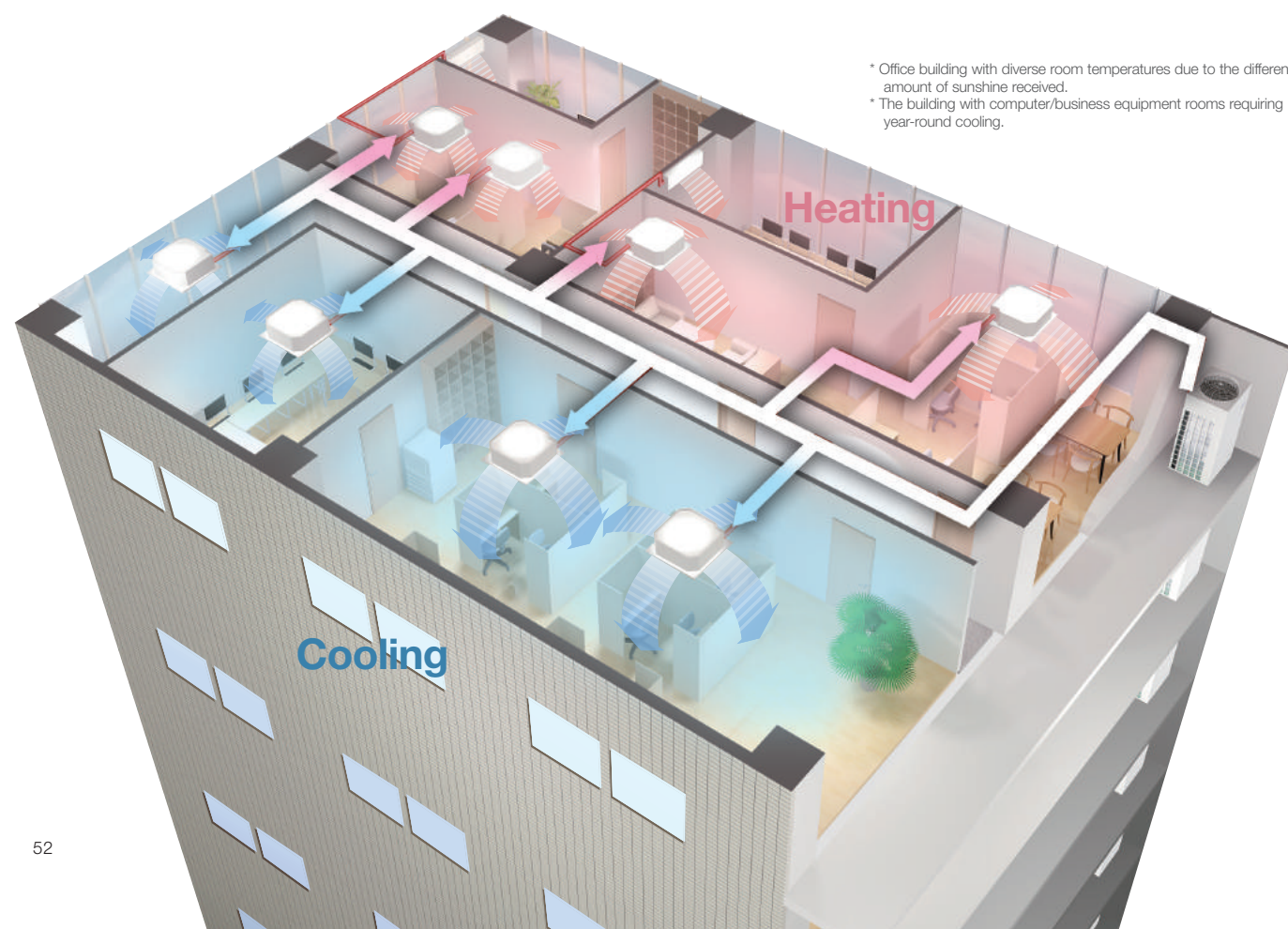

\* Office building with diverse room temperatures due to the different amount of sunshine received.  
 \* The building with computer/business equipment rooms requiring year-round cooling.

## NEW Fully-automatic simultaneous cooling/heating operation and heat recovery

3-WAY MF2 series enables simultaneous heating and cooling operation by each solenoid valve kit. New design to decrease chattering noise at low capacity load.

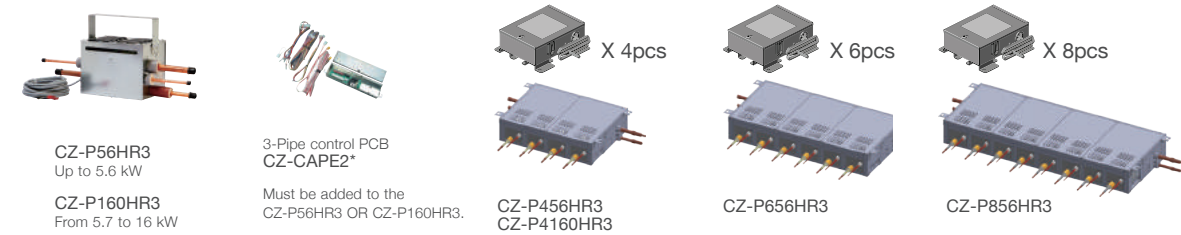

Individual control of multiple indoor units with solenoid valve kits

- Any design and layout can be used in a single system.
- Cooling operation is possible up to an outdoor temperature of -10°C DB.

\*For S-45MK1E5/S-56MK1E5/S-73MK1E5/ S-106MK1E5:CZ-CAPEK2.

### System Structure

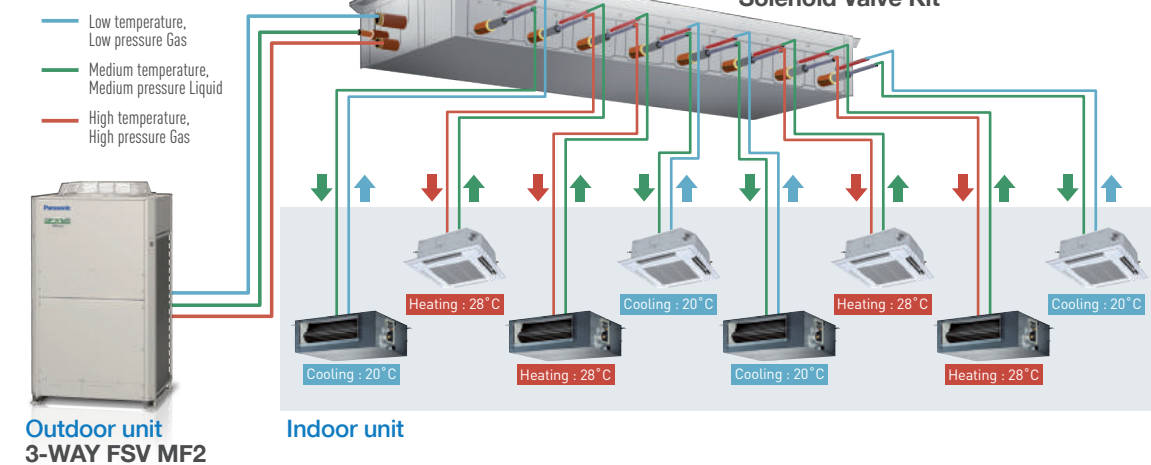

# Simultaneous heating and cooling VRF system 3-WAY FSV MF2 Series

## New Solenoid Valve Kit Multiple Connection Port Type

The new Panasonic Solenoid Valve Kit field installation work becomes more easy. In fact, our latest technology is designed new packages body without additional branch-kits and 3-way control PCB. Connection tube for main refrigerant circuit line comes on both side of the unit. It helps the system design and piping layout for more flexible.

### System Structure

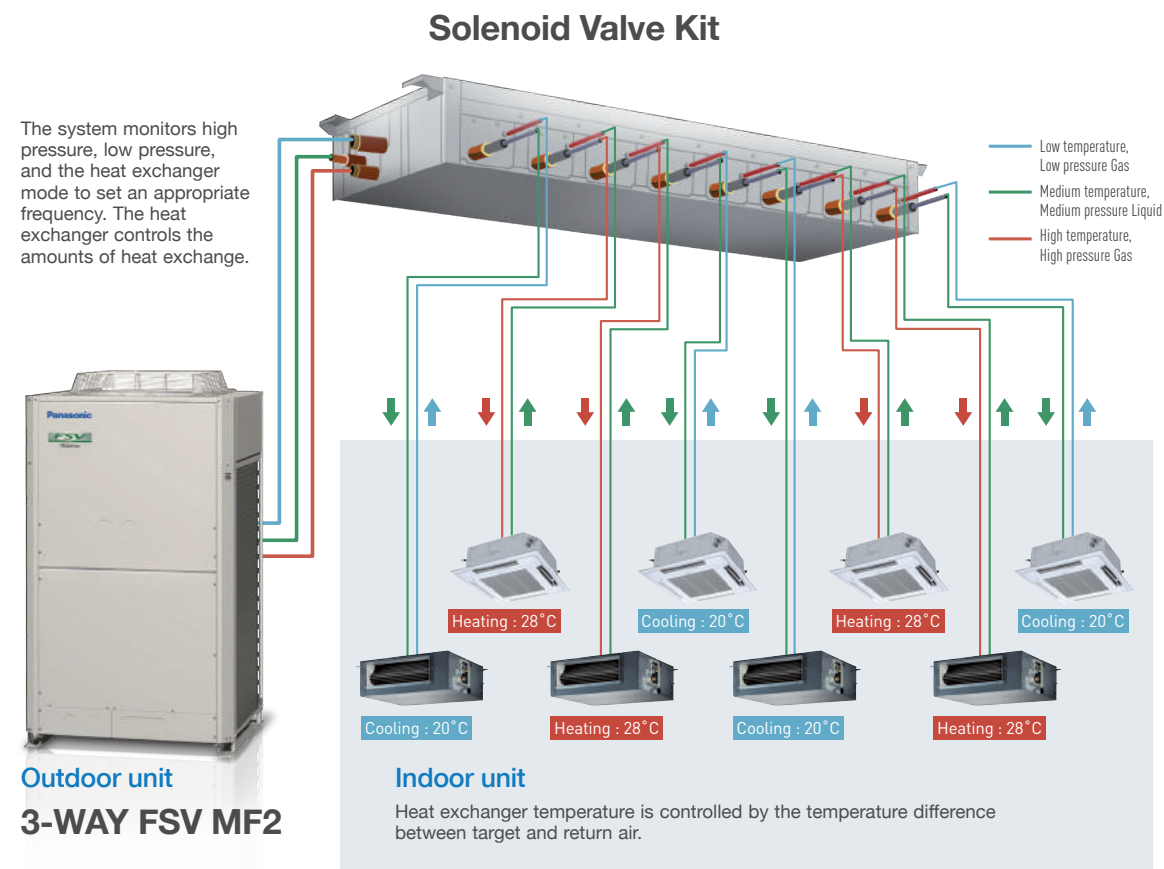

## New Model

CZ-P456HR3  
CZ-P4160HR3

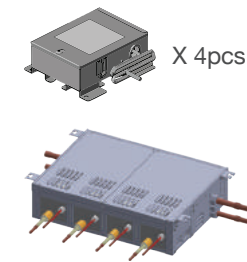

CZ-P656HR3

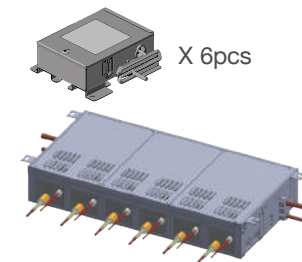

CZ-P856HR3

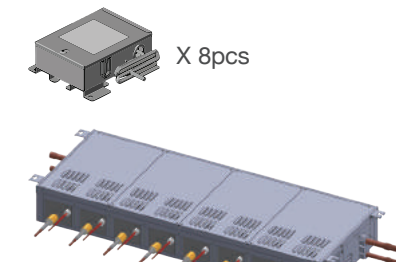

	1 port	4 port	6 port	8 port
56 type	CZ-P56HR2	<b>CZ-P456HR2</b>	<b>CZ-P656HR2</b>	<b>CZ-P856HR2</b>
160 type	CZ-P160HR2	<b>CZ-P4160HR2</b>	--	--

## Solenoid Valve Kit / Wiring Work

### Current Model / Single Connection Type

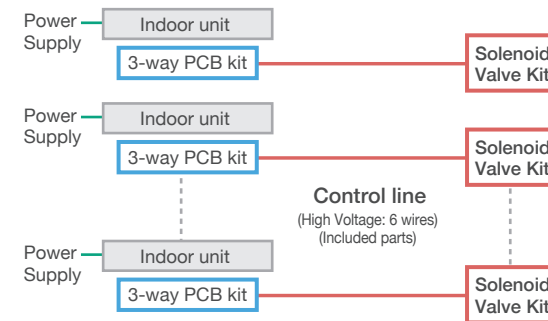

### New Model / Multiple Connection Type

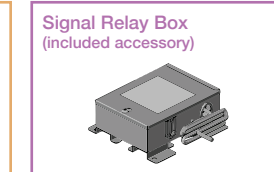
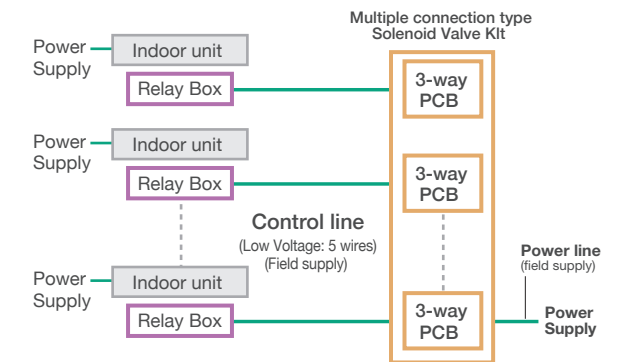

# Simultaneous heating and cooling VRF system 3-WAY FSV MF2 Series

## Increased max. number of connectable indoor units

The 3-WAY MF2 series has four DC inverter outdoor units from 8 HP to 14 HP as the basic models, and by combination of up to three units, an air-conditioning capacity of 8 HP to 42 HP can be set according to the user needs.

System (HP)	8	10	12	14	16	18	20	22	24	26	28	30	32	34	36	38	40	42
Outdoor units	8	10	12	14	8	8	8	8	10	12	14	8	12	12	14	14	14	14
Connectable indoor units	13	16	19	23	26	29	33	36	40	43	46	50	52	52	52	52	52	52

Connectable indoor/outdoor unit capacity ratio up to 150%

## Long piping design

Adaptable to various building types and sizes  
Actual piping length : 180m  
Max piping length : 500m

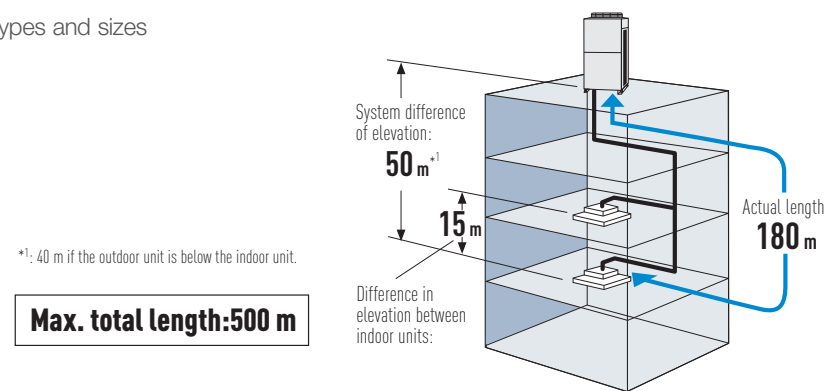

## Excellent energy saving

The operation efficiency has been improved using highly efficient R410A refrigerant, new DC inverter compressor, new DC motor and new fan guard with low-loss wire guard. In addition, heat exchanger has been redesigned from 3-direction suction to 4-direction suction to efficiently distribute air speed.

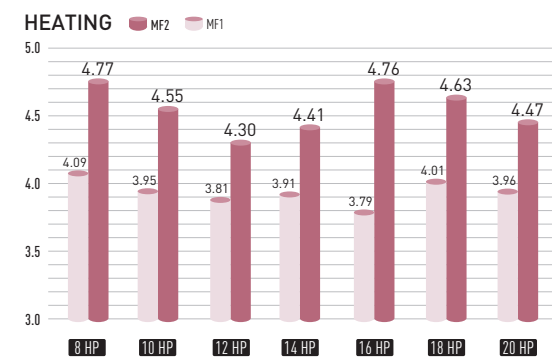
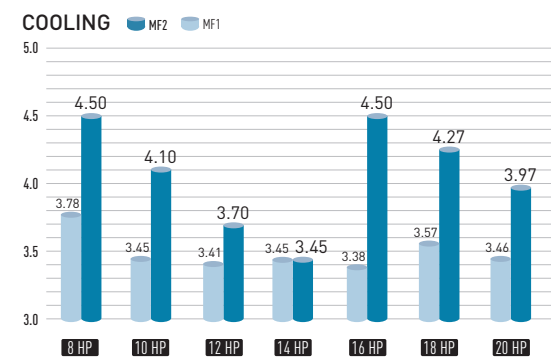

## Up to 40m piping after first branch

Up to 52 units can be connected to one system. Flexible piping layout makes it easier to design systems for locations such as train stations, airports, schools and hospitals.

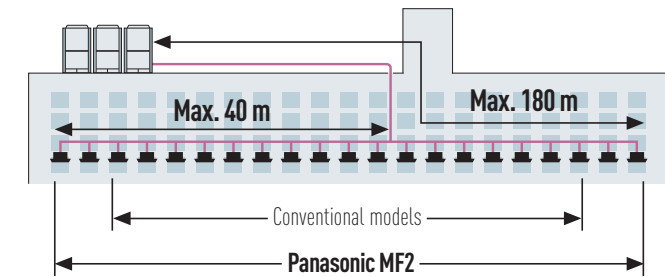

## Extended operating range

### Cooling operation range:

The cooling operation range has been extended to -10°C DB by changing the outdoor fan to an inverter type.

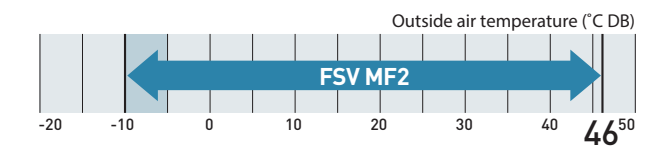

### Heating operation range:

Stable heating operation even with an outside air temperature of -20°C WB  
The heating operation range has been extended to -20°C WB by use of a compressor with a high-pressure vessel.

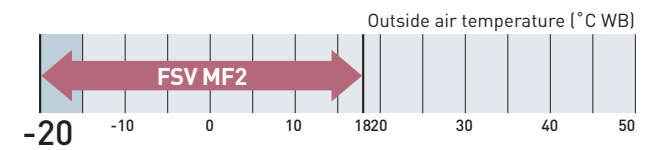

Remark: Cooling/heating capacity depend on indoor/outdoor temperature. Please refer technical databook.

## Wide temperature setting range

Wired remote control heating temperature setting range is 16 to 30°C

## Compact design

The new MF2 series has reduced the installation space required with up to 14 HP available in a single chassis. 8 - 14 HP are able to fit inside a lift for easy handling on site.

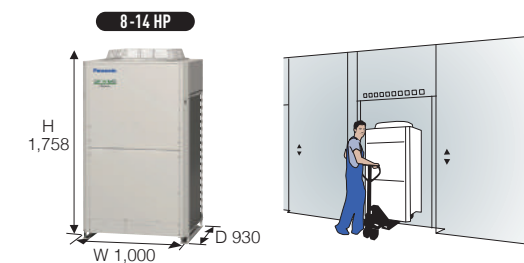

## Newly designed fan

### Optimised air flow

Newly designed fan and bell-mouth reduces stress on the fan by dispersing air quickly. Thus, lower air resistance results in lower energy consumption.

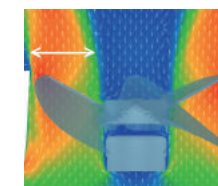

### Noise reduction

Turbulence (blue) can be suppressed and the unwanted noise can be reduced. Even though a high speed fan is utilised, the noise level is still very low.

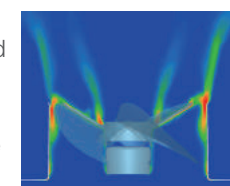

# Simultaneous heating and cooling VRF system 3-WAY FSV MF2 Series

## High outdoor unit static pressure

Customisable on site settings allow all models to provide up to 80Pa due to newly designed fan, fan guard, fan motor and casing. The flexible design allows connection of an air discharge duct to avoid a reduction in performance due to a shortage of air circulation. This feature allows the outdoor unit to be installed inside balconies on every floor of tall buildings.

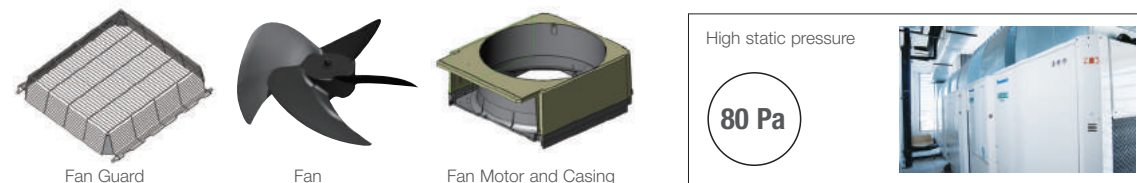

## Extended compressor life by uniform compressor operation time

The total run-time of compressors are monitored by a built-in microcomputer, which ensures that operation times of all compressors within the same refrigerant circuit are balanced.

Compressors with histories showing shorter run times are selected first, ensuring equal wear and tear across all units and extended the working life of the system.

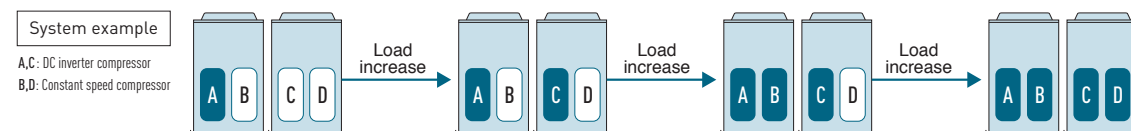

\* Depend on accumulated operation time of each compressors.  
\* Compressor priority has possibility to be changed.  
(e.g) Case1: A→C→B→D, Case2: C→A→D→B, Case3: A→C→D→B, Case4: C→A→B→D  
\* Also other cases available.

## Automatic backup operation in the case of compressor failure or outdoor unit malfunction

(Except for single unit installation)

\*Backup operation allows uninterrupted cooling or heating to continue whilst waiting for service. Users should contact their authorised service centre as soon as fault occurs.

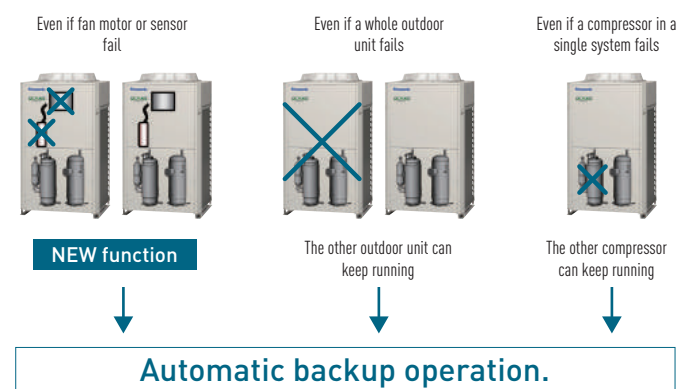

## Demand response

Featuring inverter control technology, all Panasonic FSV systems are Demand Response Management (DRM) ready. With this control, power consumption at times of peak load can be set in three steps to deliver optimum performance. This helps to reduce annual power consumption with minimal loss in comfort.

Demand control terminal is available to control 0-50-75-100% of capacities.

MF2 series features a DR terminal as standard (not a required option)

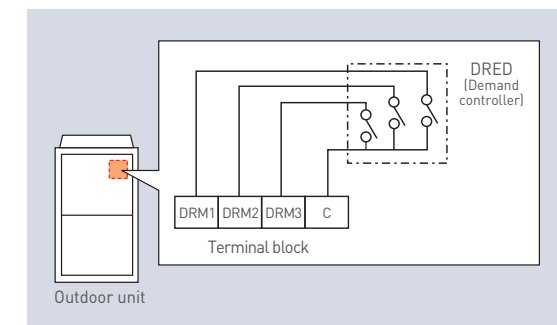

Demand Response Signal	Power Input
DRM 1	0%
DRM 2	50%
DRM 3	75%

## Flexible Demand Response with the CZ-CAPDC2\*1

Setting is possible as 0% or in the range from 40 to 100% (in steps of 5%). At the time of shipping, setting has been done to the three steps of 0%, 70% and 100%.

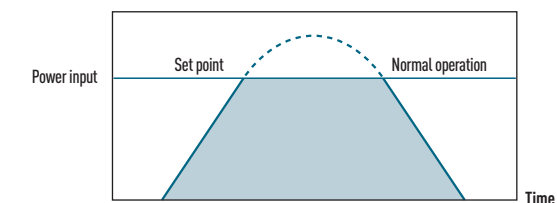

\*1 An outdoor Seri-Para I/O unit (CZ-CAPDC2) is required for demand input signal.

Power input	
Level 1	100% (Preset)
Level 2	70% (Preset)
Level 3	0% (Always in stop condition)

Possible to change 40-100%



## Hi-durability outdoor unit

Corrosion-resistance treated for high resistance to rust and salty air to assure long-lasting performance.

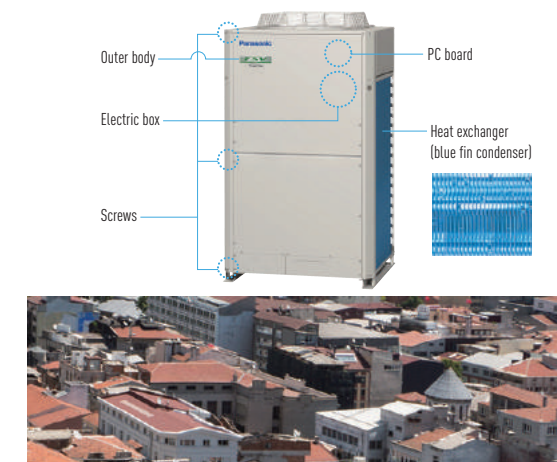
Note: Selecting this unit does not completely eliminate the possibility of rust developing. For details concerning unit installation and maintenance, please consult an authorised dealer.



# 3-WAY FSV MF2 Series

Appearance																						
HP		8	10	12	14	16	18	20	22	24	26	28	30	32	34	36	38	40	42			
Model name		U-8MF2R7B	U-10MF2R7B	U-12MF2R8B	U-14MF2R8B	U-8MF2R7B U-8MF2R7B	U-8MF2R7B U-10MF2R7B	U-8MF2R7B U-12MF2R8B		U-8MF2R7B U-14MF2R8B	U-10MF2R7B U-14MF2R8B	U-12MF2R8B U-14MF2R8B	U-8MF2R7B U-8MF2R7B U-14MF2R8B	U-8MF2R7B U-12MF2R8B	U-8MF2R7B U-12MF2R8B U-14MF2R8B	U-8MF2R7B U-14MF2R8B	U-10MF2R7B U-14MF2R8B	U-12MF2R8B U-14MF2R8B	U-14MF2R8B U-14MF2R8B			
Power supply		380/400/415V/3-phase/50Hz 380/400V/3-phase/60Hz				380/400/415V/3-phase/50Hz																
Capacity	Cooling	kW	22.4	28.0	33.5	39.2	45.0	50.4		61.5	68.0	73.0	78.5	85.0	90.0	96.0	101.0	107.0	113.0	118.0		
		BTU/h	76,500	95,600	114,300	133,800	153,600	172,000	191,100		209,900	232,100	249,100	267,900	290,100	307,200	327,600	344,700	365,200	385,700	402,700	
EER / COP	Cooling	W/W	3.94	3.47	3.52	3.14	3.95	3.68	3.66		3.40	3.25	3.29	3.13	3.50	3.60	3.42	3.28	3.21	3.23	3.13	
	Heating	W/W	4.49	3.88	4.08	3.85	4.50	4.12	4.20		4.80	3.86	3.98	3.91	4.17	4.17	4.04	4.01	3.90	3.92	3.89	
Dimensions	H x W x D	mm	1,758x1,000x 930	1,758x1,000x 930	1,758x1,000x 930	1,758x1,000x 930	1,758x2,060x 930	1,758x2,060x 930	1,758x2,060x 930	1,758x2,060x 930	1,758x2,060x 930	1,758x2,060x 930	1,758x3,120x 930	1,758x3,120x 930	1,758x3,120x 930	1,758x3,120x 930	1,758x3,120x 930	1,758x3,120x 930	1,758x3,120x 930	1,758x3,120x 930		
Net weight		kg	269	269	314	322	538	538	583		591	591	636	644	860	897	905	913	913	958	966	
Electrical ratings	Cooling	Running current	A	9.38/8.91/8.59	13.0/12.4/11.9	16.1/15.3/14.7	20.6/19.6/18.9	18.8/17.9/17.2	22.1/21.0/20.3	25.5/24.3/23.4		29.9/28.4/27.4	34.1/32.4/31.3	36.7/34.8/33.6	41.5/39.4/38.0	40.1/38.1/36.8	41.7/39.7/38.2	46.4/44.1/42.5	50.9/48.3/46.6	54.4/51.7/49.8	57.8/54.9/52.9	62.3/59.2/57.0
		Power input	kW	5.68	8.06	9.53	12.5	11.4	13.7	15.3		18.1	20.9	22.2	25.1	24.3	25.0	28.1	30.8	33.3	35.0	37.7
	Heating	Running current	A	9.30/8.83/8.52	13.4/12.7/12.3	15.7/14.9/14.4	19.5/18.6/17.9	18.3/17.4/16.8	22.1/21.0/20.3	25.0/23.8/22.9		27.9/26.5/25.6	32.4/30.7/29.6	33.9/32.2/31.0	37.0/35.1/33.9	37.7/35.8/34.5	40.1/38.1/36.7	44.1/41.9/40.4	46.6/44.2/42.6	49.8/47.3/45.6	53.5/50.8/49.0	56.0/53.2/51.3
		Power input	kW	5.57	8.12	9.20	11.7	11.1	13.7	15.0		16.9	19.8	20.5	22.4	22.8	24.0	26.7	28.2	30.5	32.4	33.9
Air flow rate		m³/h	9,480	10,680	12,720	12,720	18,960	20,160	22,200		22,200	22,200	25,440	25,440	31,680	34,920	34,920	34,920	36,120	38,160	38,160	
		L/s	2,633	2,967	3,533	3,533	5,267	5,600	6,167		6,167	6,167	7,067	7,067	8,800	9,700	9,700	9,700	10,033	10,600	10,600	
Refrigerant amount at shipment		kg	8.3	8.5	8.8	9.3	16.6	16.8	17.1		17.6	17.8	18.1	18.6	25.9	25.9	26.4	26.9	27.1	27.4	27.9	
Piping connections	Suction pipe	mm (inches)	Ø19.05 (Ø3/4)	Ø22.22 (Ø7/8)	Ø25.40 (Ø1)	Ø25.40 (Ø1)	Ø28.58 (Ø1-1/8)	Ø28.58 (Ø1-1/8)	Ø28.58 (Ø1-1/8)		Ø28.58 (Ø1-1/8)	Ø28.58 (Ø1-1/8)	Ø31.75 (Ø1-1/4)	Ø31.75 (Ø1-1/4)	Ø31.75 (Ø1-1/4)	Ø31.75 (Ø1-1/4)	Ø31.75 (Ø1-1/4)	Ø38.1 (Ø1-1/2)	Ø38.1 (Ø1-1/2)	Ø38.1 (Ø1-1/2)	Ø38.1 (Ø1-1/2)	
	Discharge pipe	mm (inches)	Ø15.88 (Ø5/8)	Ø19.05 (Ø3/4)	Ø19.05 (Ø3/4)	Ø22.22 (Ø7/8)	Ø22.22 (Ø7/8)	Ø22.22 (Ø7/8)	Ø22.22 (Ø7/8)		Ø25.40 (Ø1)	Ø25.40 (Ø1)	Ø25.40 (Ø1)	Ø28.58 (Ø1-1/8)	Ø28.58 (Ø1-1/8)	Ø28.58 (Ø1-1/8)	Ø28.58 (Ø1-1/8)	Ø28.58 (Ø1-1/8)	Ø31.75 (Ø1-1/4)	Ø31.75 (Ø1-1/4)	Ø31.75 (Ø1-1/4)	
	Liquid pipe	mm (inches)	Ø9.52 (Ø3/8)	Ø9.52 (Ø3/8)	Ø12.70 (Ø1/2)	Ø12.70 (Ø1/2)	Ø12.70 (Ø1/2)	Ø15.88 (Ø5/8)	Ø15.88 (Ø5/8)		Ø15.88 (Ø5/8)	Ø15.88 (Ø5/8)	Ø19.05 (Ø3/4)	Ø19.05 (Ø3/4)	Ø19.05 (Ø3/4)	Ø19.05 (Ø3/4)	Ø19.05 (Ø3/4)	Ø19.05 (Ø3/4)	Ø19.05 (Ø3/4)	Ø19.05 (Ø3/4)	Ø19.05 (Ø3/4)	Ø19.05 (Ø3/4)
	Balance pipe	mm (inches)	Ø6.35 (Ø1/4)	Ø6.35 (Ø1/4)	Ø6.35 (Ø1/4)	Ø6.35 (Ø1/4)	Ø6.35 (Ø1/4)	Ø6.35 (Ø1/4)	Ø6.35 (Ø1/4)		Ø6.35 (Ø1/4)	Ø6.35 (Ø1/4)	Ø6.35 (Ø1/4)	Ø6.35 (Ø1/4)	Ø6.35 (Ø1/4)	Ø6.35 (Ø1/4)	Ø6.35 (Ø1/4)	Ø6.35 (Ø1/4)	Ø6.35 (Ø1/4)	Ø6.35 (Ø1/4)	Ø6.35 (Ø1/4)	Ø6.35 (Ø1/4)
Ambient temperature operating range			Cooling/Dry: -10°C~+46°C (DB). Heating: -20°C~+18°C (WB) Simultaneous operation: -10°C~+24°C (DB)																			
Sound pressure level	Normal mode	dB (A)	57	59	61	62	60	61	62.5		63	64	64.5	65	64	65	65	65.5	66	66.5	67	
	Silent mode	dB (A)	54	56	58	59	57	58	59.5		60	61	61.5	62	61	62	62	62.5	63	63.5	64	

These specifications are subject to change without notice.  
 \* For mixed heating and cooling operation with an outdoor temperature in excess of 24°C DB, please use 50% or more of the horsepower of the outdoor unit for cooling operation.

## System example

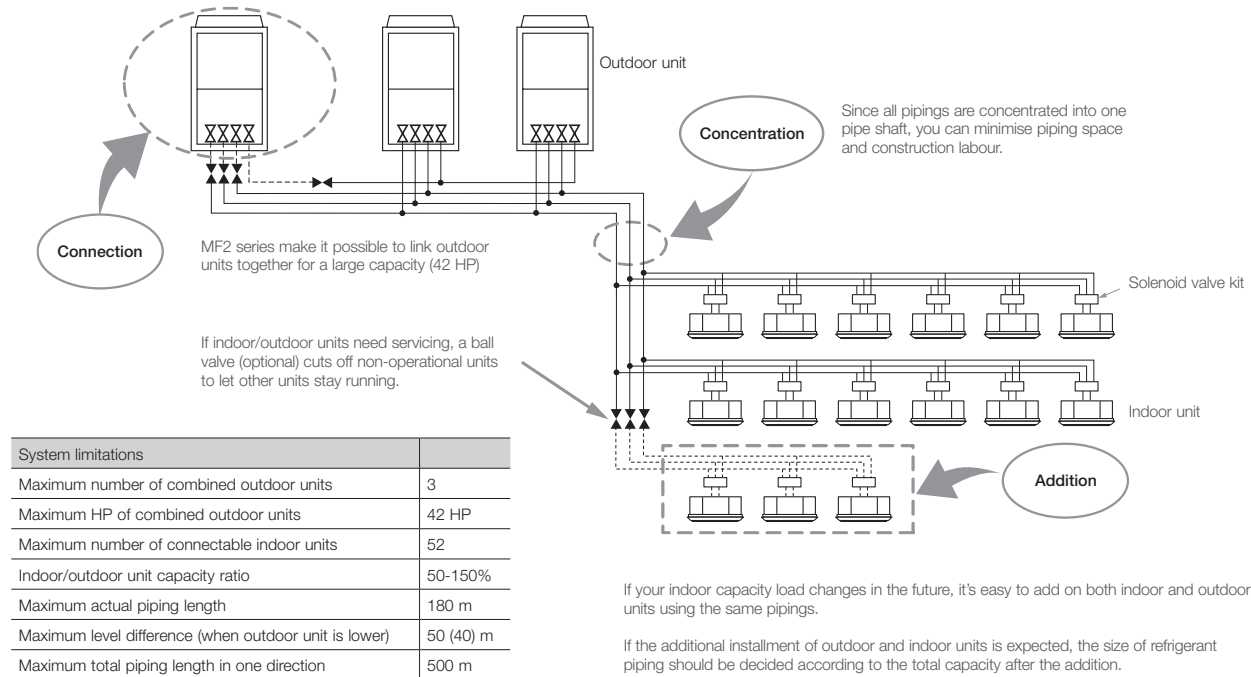

## Dimensions

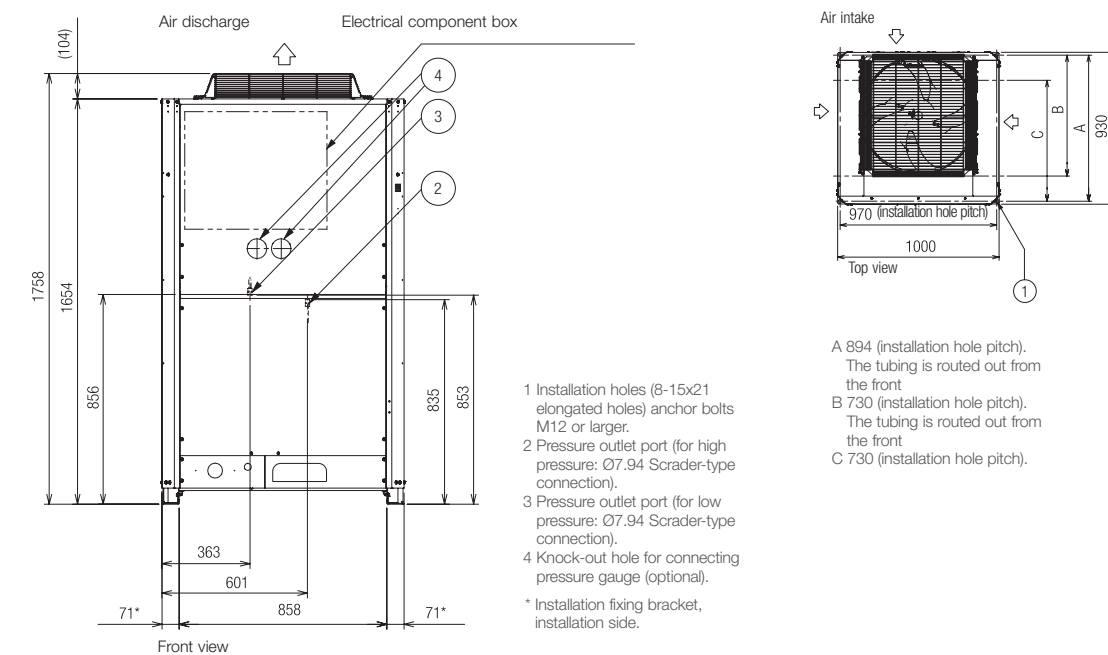

## Piping design

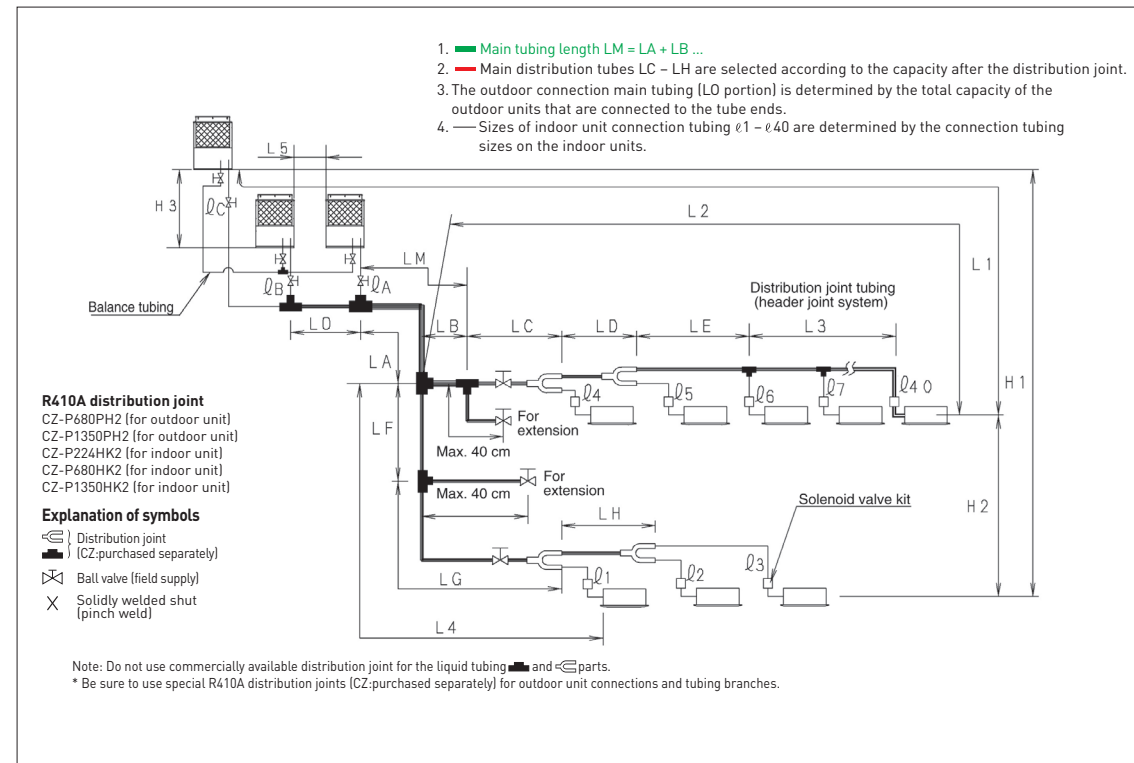

### Ranges that apply to refrigerant piping lengths and to differences in installation heights

Items	Mark	Contents	Length (m)
Allowable piping length	L1	Max. piping length	Actual piping length $\leq 180$ Equivalent piping length $\leq 200$
	$\Delta L (L2 - L4)$	Difference between the max. length and the min. length from the No.1 distribution joint	$\leq 40$
	LM	Max. length of main piping (at max. diameter)	—
	$\phi 1, \phi 2 \dots \phi 40$	Max. length of each distribution pipe	$\leq 30$
	$L1 + \phi 1 + \phi 2 \dots \phi 39 + \phi A + \phi B + L F + L G + L H$	Total max. piping length including length of each distribution (only liquid tubing)	$\leq 500$
Allowable elevation difference	L5	Distance between Outdoor unit	$\leq 10$
	H1	When outdoor unit is installed higher than indoor unit	$\leq 50$
	H2	When outdoor unit is installed lower than indoor unit	$\leq 40$
Allowable length of joint tubing	H3	Max. difference between indoor units	$\leq 15$
	L3	Max. difference between outdoor units	$\leq 4$
Allowable length of joint tubing	L3	Distribution joint tubing ; Max. tubing length between the first distribution joint and solidly welded-shut end point	$\leq 2$

L = Length, H = Height  
 □ If the longest tubing length (L1) exceeds 90 m (equivalent length), increase the sizes of the main tubes (LM) by 1 rank for the discharge tubes, and narrow tubes. (field supplied).  
 □ If the longest main tube length (LM) exceeds 50 m, increase the main tube size at the portion before 50 m by 1 rank for the suction tubes and discharge tubes. (field supplied). (For the portion that exceeds 50 m, set based on the main tube sizes [LA] listed in the table on the following page).  
 □ 30HP of combination is 300 m.

### System limitations

Max. number of combined outdoor units	3
Max. HP of combined outdoor units	118 kW (42 hp)
Max. number of connectable indoor units	52
Indoor/outdoor unit capacity ratio	50-150%

\*1: In the case of 24 hp (type 68.0 kW) or smaller units, the number is limited by the total capacity of the connected indoor units.  
 \*2: Up to 3 units can be connected if the system has been extended.  
 \*3: It is strongly recommended that you choose the unit so the load can become between 50 and 130 %.

### Additional refrigerant charge

Liquid piping size mm (inches)	Amount of refrigerant charge/m (g/m)
ø6.35 (ø1/4)	26
ø9.52 (ø3/8)	56
ø12.7 (ø1/2)	128
ø15.88 (ø5/8)	185
ø19.05 (ø3/4)	259
ø22.22 (ø7/8)	366

### Distribution joint kits

Remarks	Model name	Cooling capacity after distribution
For outdoor unit	1. CZ-P680PH2	68.0 kW or less
	2. CZ-P1350PH2	118.0 kW or less
	3. CZ-P224BH2	22.4 kW or less
For indoor unit	4. CZ-P680BH2	68.0 kW or less
	5. CZ-P1350BH2	118.0 kW or less

### Refrigerant piping

Piping size mm (inches)		1/2 H, H material	
Material 0	Outer diameter	Outer diameter	Wall thickness
ø6.35 (ø1/4)	t 0.8 mm	ø22.22 (ø7/8)	t 1.15 mm
ø9.52 (ø3/8)	t 0.8 mm	ø 25.4 (ø1)	t 1.0 mm
ø12.7 (ø1/2)	t 0.8 mm	ø 28.58 (ø1-1/8)	t 1.0 mm
ø15.88 (ø5/8)	t 1.0 mm	ø 31.75 (ø1-1/4)	t 1.1 mm
ø19.05 (ø3/4)	t 1.0 mm	ø 38.1 (ø1-1/2)	t 1.15 mm
		ø 41.28 (ø1-5/8)	t 1.20 mm

Note: When pipe bending is to be performed, the bending radius shall be at least 4 times the outer diameter. Also, take sufficient care to prevent pipe collapse and damage at the time of bending.





# Refrigerant Branch Pipes (optional accessories) for 3-Way MF2 Series

## Optional Distribution Joint Kits

See the installation instructions packaged with the distribution joint kit for the installation procedure.

Model name	capacity after distribution JOINT	Remarks
1. CZ-P680PH2	68.0 kW or less	For outdoor unit
2. CZ-P1350PH2	greater than 68.0 kW and no more than 118.0 kW	For outdoor unit
3. CZ-P224BH2	22.4 kW or less	For indoor unit
4. CZ-P680BH2	greater than 22.4 kW and no more than 68.0 kW	For indoor unit
5. CZ-P1350BH2	greater than 68.0 kW and no more than 118.0 kW	For indoor unit

### 1. CZ-P680PH2

Use: For outdoor unit (Capacity after distribution joint is 68.0 kW or less.)

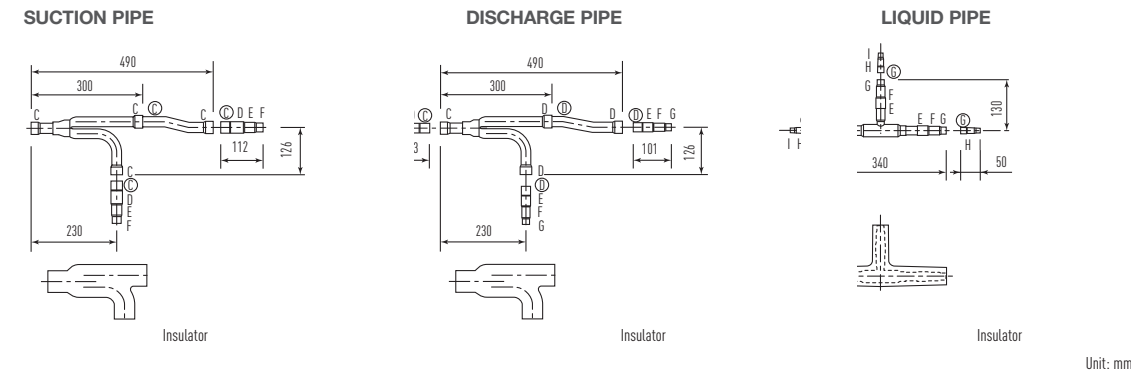

Dimensions for connections of each part										
Position	A	B	C	D	E	F	G	H	I	J
Dimension (mm)	Ø38.10	Ø31.75	Ø28.58	Ø25.40	Ø22.22	Ø19.05	Ø15.88	Ø12.70	Ø9.52	Ø6.35
Dimension (inches)	Ø1-1/2	Ø1-1/4	Ø1-1/8	Ø1	Ø7/8	Ø3/4	Ø5/8	Ø1/2	Ø3/8	Ø1/4

### 2. CZ-P1350PH2

Use: For outdoor unit (Capacity after distribution joint is greater than 68.0 kW and no more than 118.0 kW.)

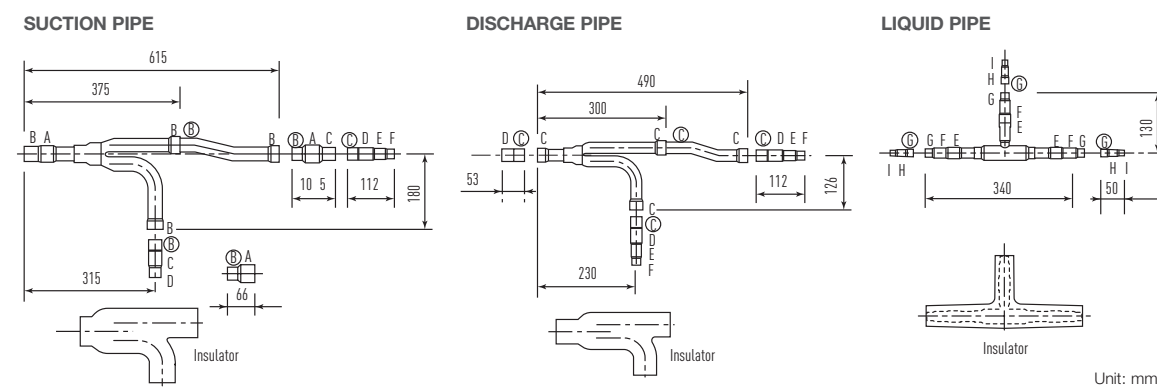

Dimensions for connections of each part										
Position	A	B	C	D	E	F	G	H	I	J
Dimension (mm)	Ø38.10	Ø31.75	Ø28.58	Ø25.40	Ø22.22	Ø19.05	Ø15.88	Ø12.70	Ø9.52	Ø6.35
Dimension (inches)	Ø1-1/2	Ø1-1/4	Ø1-1/8	Ø1	Ø7/8	Ø3/4	Ø5/8	Ø1/2	Ø3/8	Ø1/4

Example: (F below indicates inner diameter. ⊕ below indicates outer diameter.)

### 3. CZ-P224BH2

Use: For indoor unit (Capacity after distribution joint is 22.4 kW or less.)

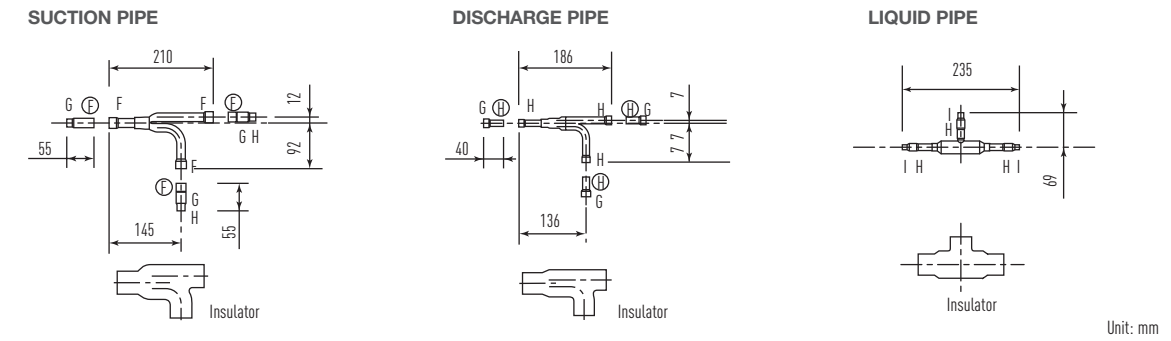

Dimensions for connections of each part										
Position	A	B	C	D	E	F	G	H	I	J
Dimension (mm)	Ø38.10	Ø31.75	Ø28.58	Ø25.40	Ø22.22	Ø19.05	Ø15.88	Ø12.70	Ø9.52	Ø6.35
Dimension (inches)	Ø1-1/2	Ø1-1/4	Ø1-1/8	Ø1	Ø7/8	Ø3/4	Ø5/8	Ø1/2	Ø3/8	Ø1/4

### 4. CZ-P680BH2

Use: For indoor unit (Capacity after distribution joint is greater than 22.4 kW and no more than 68.0 kW.)

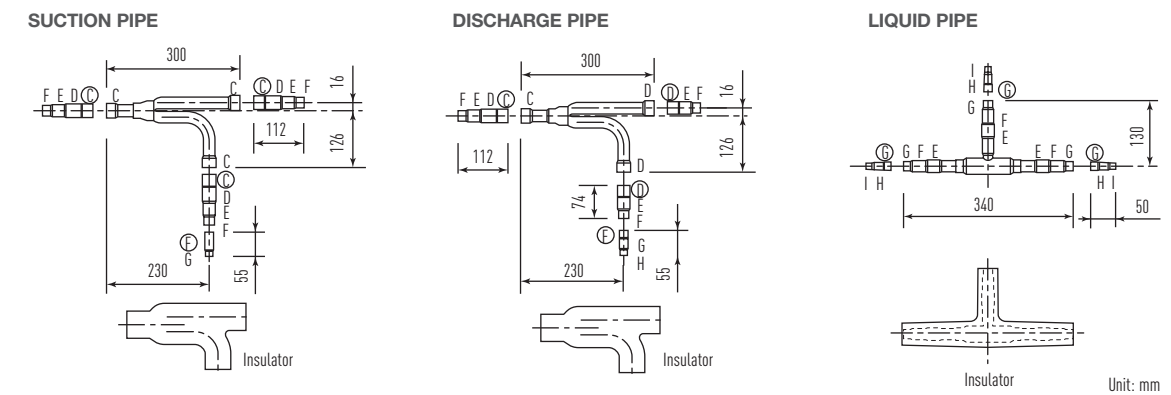

Dimensions for connections of each part										
Position	A	B	C	D	E	F	G	H	I	J
Dimension (mm)	Ø38.10	Ø31.75	Ø28.58	Ø25.40	Ø22.22	Ø19.05	Ø15.88	Ø12.70	Ø9.52	Ø6.35
Dimension (inches)	Ø1-1/2	Ø1-1/4	Ø1-1/8	Ø1	Ø7/8	Ø3/4	Ø5/8	Ø1/2	Ø3/8	Ø1/4

### 5. CZ-P1350BH2

Use: For indoor unit (Capacity after distribution joint is greater than 68.0 kW and no more than 118.0 kW.)

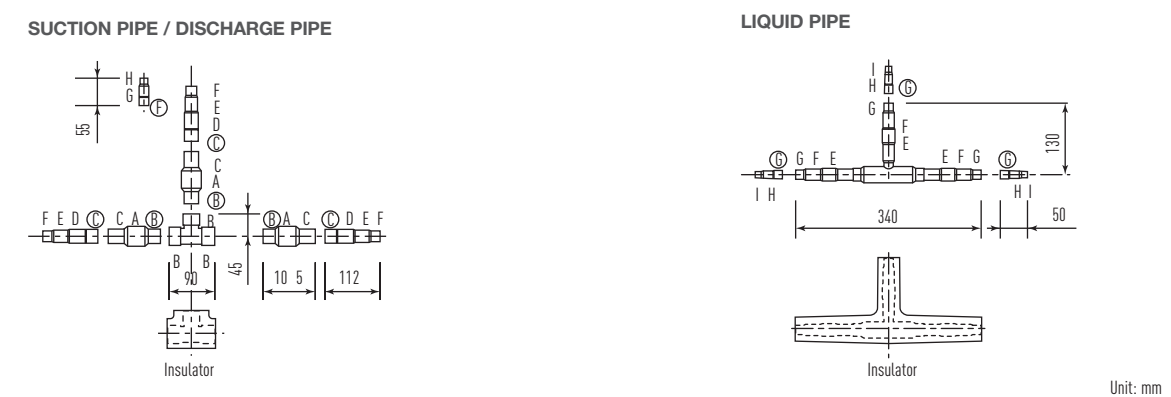

Dimensions for connections of each part										
Position	A	B	C	D	E	F	G	H	I	J
Dimension (mm)	Ø38.10	Ø31.75	Ø28.58	Ø25.40	Ø22.22	Ø19.05	Ø15.88	Ø12.70	Ø9.52	Ø6.35
Dimension (inches)	Ø1-1/2	Ø1-1/4	Ø1-1/8	Ø1	Ø7/8	Ø3/4	Ø5/8	Ø1/2	Ø3/8	Ø1/4

# Indoor Units

Wide choice of models depending on the indoor requirements

## Key Indoor Units Equipped DC motors

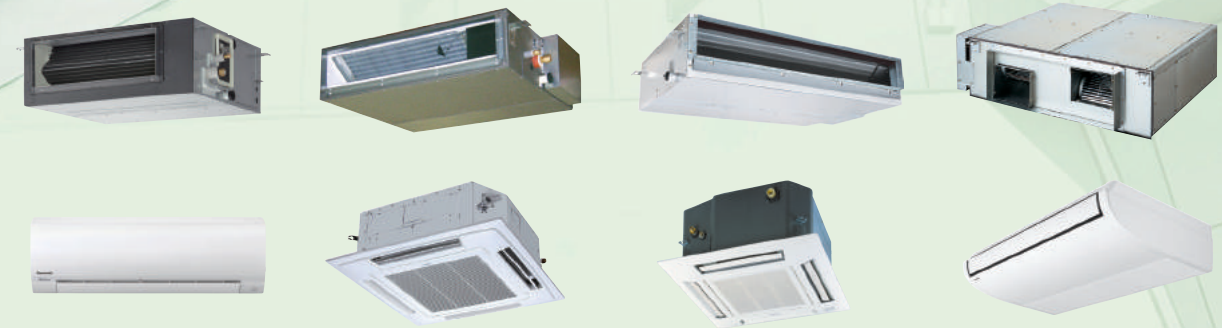

### ECONAVI sensor



Providing outstanding energy-saving performance, Panasonic's inverter VRF System can be connected to ECONAVI to detect when energy is being wasted. ECONAVI senses the presence or absence of people and the level of activity in each area of an office. When unnecessary heating or cooling is detected, indoor units are individually controlled to match office conditions for energy-saving operation.



ECONAVI Sensor CZ-CENSC1

#### Detection of the level of activity enables optimum power saving

Activity or absence of people at their desks and the level of activity in the office are detected in real time. Cooling or heating is automatically adjusted for optimum operation required to lower power consumption.

#### Sensor is remotely located to maximize the energy saving effect

Pillars, walls, cabinets and other fittings obstruct the sensors, reducing the area of detection and lowering the energy-saving effect. Taking into consideration blind spots, Panasonic enables the optimum layout for sensors in any office.

### NEW High-spec Wired Remote Controller



#### Large 3.5" full-dot LCD with white LED backlight

Characters and icons are clearly displayed for improved visibility. The display is also large enough to provide a wide range of information for easy confirmation of operation conditions.



#### Stylish, easy-to-use touch key design

The elegant, flat design features large touch keys in a simple layout enabling easy, intuitive operation.



### All Ducted Series / F2,M1,Z1,E2,E1,H1, type

#### Discharge air temperature control

Smart sensors control discharge air temperature for precise room temperature control. Possible to reduce cold drafts during heating operation.

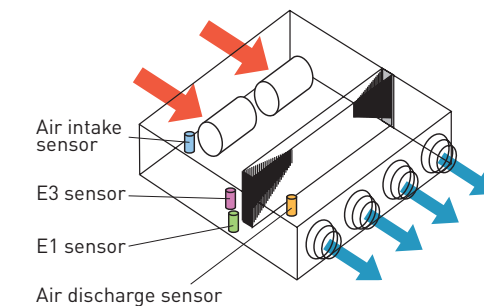

### Wall Mounted / K2,K1 type



Compact design with flat surface enables seamless match with any type of room interior

#### Noise reducing external valve kit

To reduce noise level of expansion valve. (Optional accessory)

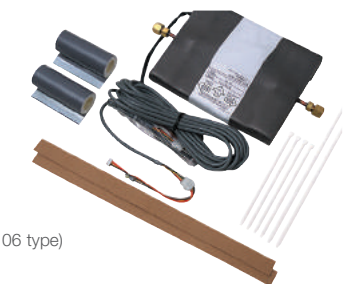

CZ-P56SVK2 (for 22 - 56 type)  
CZ-P160SVK2 (for 73 - 106 type)

### NEW Remote Temperature Sensor



CZ-CSRC3

- This is a remote sensor which can be used with indoor units. Use it to detect the room temperature when no remote controller sensor or body sensor is used (connection to a system without a remote controller is possible).
- For joint use with a remote control switch, use the remote control switch as main remote controller.

# FSV Indoor Units Range

Wide choice of models depending on the indoor requirements

Class	22	28	36	45	56	60	73	90	106	140	160	180	224	280	Wireless remote control	Functions	
	Capacity Type	2.2/2.5 7,500/8,500	2.8/3.2 9,600/11,000	3.6/4.2 12,000/14,000	4.5/5.0 15,000/17,000	5.6/6.3 19,000/21,000	6.0/7.1 20,400/24,200	7.3/8.0 25,000/27,000	9.0/10.0 30,000/34,000	10.6/11.4 36,000/39,000	14.0/16.0 47,800/54,600	16.0/18.0 54,600/61,500	18.0/20.0 61,400/68,200	22.4/25.0 76,400/85,300			28.0/31.5 95,500/107,500
F2 type <b>ECONAVI</b> Mid Static Ducted	S-22MF2E5A	S-28MF2E5A	S-36MF2E5A	S-45MF2E5A	S-56MF2E5A	S-60MF2E5A	S-73MF2E5A	S-90MF2E5A	S-106MF2E5A	S-140MF2E5A	S-160MF2E5A				●	self-diagnosing, Auto fan, DRY, Auto restart, Drain pump, DC motor	
M1 type <b>ECONAVI</b> Slim Low Static Ducted	S-22MM1E5A	S-28MM1E5A	S-36MM1E5A	S-45MM1E5A	S-56MM1E5A										●	self-diagnosing, Auto fan, DRY, Auto restart, Drain pump, DC motor	
Z1 type <b>ECONAVI</b> Slim Low Static Ducted Twenty Series	S-22MZ1H4A	S-28MZ1H4A	S-36MZ1H4A	S-45MZ1H4A	S-56MZ1H4A	S-60MZ1H4A	S-73MZ1H4A								●	self-diagnosing, Auto fan, DRY, Auto restart, DC motor	
E2 type High Static Ducted / Energy Saving High-Fresh Air Ducted												S-180ME2E5 *	S-224ME2E5 High Fresh Air	S-280ME2E5 High Fresh Air		●	self-diagnosing, Auto fan, DRY, Auto restart, DC motor
E1 type High Static Ducted							S-73ME1E5		S-106ME1E5	S-140ME1E5			S-224ME1E5	S-280ME1E5	●	self-diagnosing, Auto fan, DRY, Auto restart	
H1 type High Fresh Air Ducted										S-140MH1H5 High Fresh Air			S-224MH1H5 High Fresh Air	S-280MH1H5 High Fresh Air		self-diagnosing, Auto fan, Auto restart	
K2 type <b>ECONAVI</b> K1 type Wall Mounted	S-22MK2E5A	S-28MK2E5A	S-36MK2E5A	S-45MK1E5A	S-56MK1E5A		S-73MK1E5A		S-106MK1E5A						●	self-diagnosing, Auto fan, DRY, Auto restart, Air swing, DC motor, AUTO flap	
U1 type <b>ECONAVI</b> 4-Way Cassette Panel No. CZ-KPU21	S-22MU1E5A	S-28MU1E5A	S-36MU1E5A	S-45MU1E5A	S-56MU1E5A	S-60MU1E5A	S-73MU1E5A	S-90MU1E5A	S-106MU1E5A	S-140MU1E5A	S-160MU1E5A				●	self-diagnosing, Auto fan, DRY, Auto restart, Air swing, Drain pump, DC motor, AUTO flap	
Y2 type <b>ECONAVI</b> 4-Way Mini Cassette Panel No. CZ-KPY3A	S-22MY2E5A	S-28MY2E5A	S-36MY2E5A	S-45MY2E5A	S-56MY2E5A										●	self-diagnosing, Auto fan, DRY, Auto restart, Air swing, Drain pump, DC motor, AUTO flap	
L1 type 2-Way Cassette Panel No. CZ-02KPL2 Panel No. CZ-03KPL2 (Only for S-73ML1E5)	S-22ML1E5	S-28ML1E5	S-36ML1E5	S-45ML1E5	S-56ML1E5		S-73ML1E5								●	self-diagnosing, Auto fan, DRY, Auto restart, Air swing, Drain pump, AUTO flap	
D1 type 1-Way Cassette Panel No. CZ-KPD2		S-28MD1E5	S-36MD1E5	S-45MD1E5	S-56MD1E5		S-73MD1E5								●	self-diagnosing, Auto fan, DRY, Auto restart, Air swing, Drain pump, AUTO flap	
T2 type <b>ECONAVI</b> Ceiling			S-36MT2E5A	S-45MT2E5A	S-56MT2E5A		S-73MT2E5A		S-106MT2E5A	S-140MT2E5A					●	self-diagnosing, Auto fan, DRY, Auto restart, Air swing, DC motor, AUTO flap	
P1 type Floor Standing	S-22MP1E5	S-28MP1E5	S-36MP1E5	S-45MP1E5	S-56MP1E5		S-71MP1E5								●	self-diagnosing, Auto fan, DRY, Auto restart	
R1 type Concealed Floor Standing	S-22MR1E5	S-28MR1E5	S-36MR1E5	S-45MR1E5	S-56MR1E5		S-71MR1E5								●	self-diagnosing, Auto fan, DRY, Auto restart	

\* Only for High Static Ducted



# F2 TYPE Mid Static Ducted



The new F2 type is designed specifically for applications requiring fixed square ducting. An anti-mould filter is equipped as standard.



S-60MF2E5A / S-73MF2E5A / S-90MF2E5A

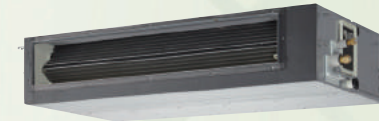

S-106MF2E5A / S-140MF2E5A / S-160MF2E5A



S-22MF2E5A / S-28MF2E5A / S-36MF2E5A / S-45MF2E5A / S-56MF2E5A

**ECONAVI**  
ECONAVI ready



CZ-CENSC1 CZ-RTC5



Self-diagnosing Function



Automatic Fan Operation



Mild dry



Automatic Restart Function



Built-in Drain Pump

## Technical focus

- Variable external static pressure control
- Industry-leading low sound levels from 25 dB(A)
- Built-in drain pump provides 702 mm lift
- Easy to install and maintain
- Air off sensor avoids cold air drafts during heating operation
- Configurable air temperature control
- Anti-mould washable filters included

## Variable external static pressure control

Optimal airflow set-up is possible depending on ducting design and conditions.

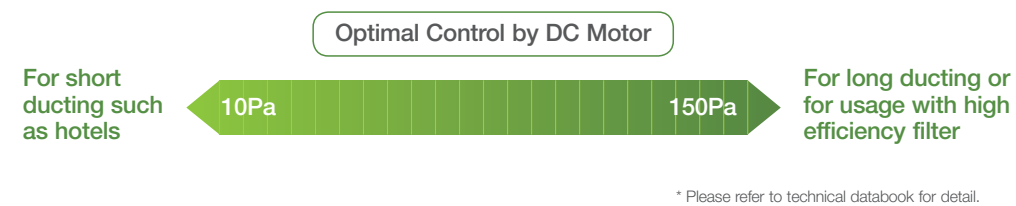

## System example

An inspection port (450 mm x 450 mm or larger) is required at the lower side of the indoor unit body.

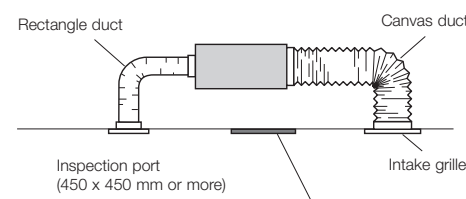

## More powerful drain pump

Using a high-lift drain pump, drain piping can be elevated up to 702 mm from the base of the unit.

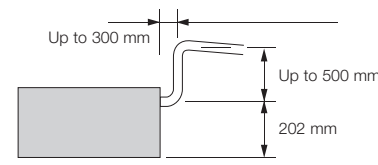

Built-in Drain pump (DC motor pump)

Standardised height of 290 mm for all models

Height standardisation enables easy and uniform installation for models with different capacities.

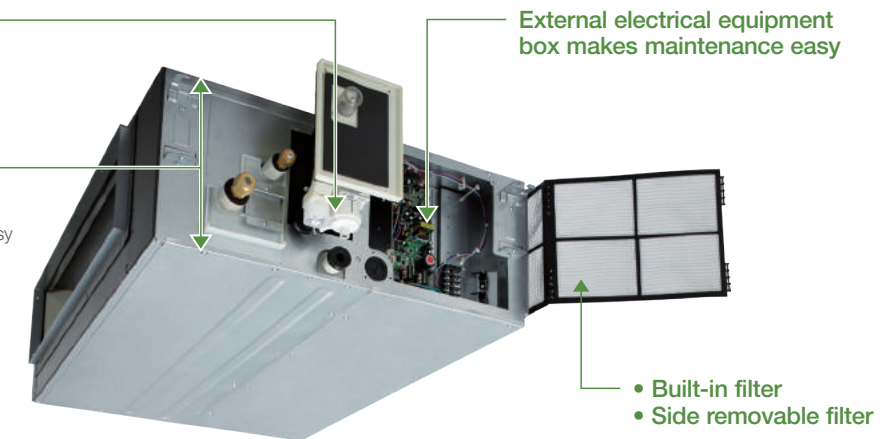

## Discharge air temperature control

- Possible to control discharge air temperature for accurate room temperature control.
  - Possible to reduce cold drafts during heating operation.
- Before spec-in, please consult with an authorised Panasonic dealer.

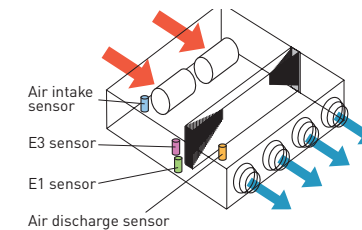

## V-shaped heat exchanger

To improve heat exchange efficiency, an original V-shaped heat exchanger was developed incorporating a conventional high-efficiency slit fan and high-efficiency grooved heat transfer tubes. This increases the heat exchange surface area by about 80%.

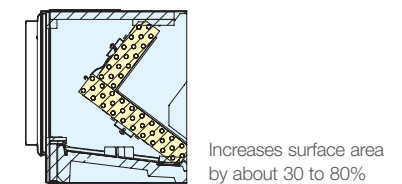

# F2<sub>TYPE</sub> Mid Static Ducted

Model Name		S-22MF2E5A	S-28MF2E5A	S-36MF2E5A	S-45MF2E5A	S-56MF2E5A	S-60MF2E5A	S-73MF2E5A	S-90MF2E5A	S-106MF2E5A	S-140MF2E5A	S-160MF2E5A	
Power source		220/230/240V, 1 phase - 50/60Hz						220/230/240V, 1 phase - 50/60Hz					
Cooling capacity	kW	2.2	2.8	3.6	4.5	5.6	6.0	7.3	9.0	10.6	14.0	16.0	
	BTU/h	7,500	9,600	12,000	15,000	19,000	20,400	25,000	30,000	36,000	47,800	54,600	
Heating capacity	kW	2.5	3.2	4.2	5.0	6.3	7.1	8.0	10.0	11.4	16.0	18.0	
	BTU/h	8,500	11,000	14,000	17,000	21,000	24,200	27,000	34,000	39,000	54,600	61,500	
Power input	Cooling kW	0.070/0.070/0.070	0.070/0.070/0.070	0.070/0.070/0.070	0.070/0.070/0.070	0.100/0.100/0.100	0.120/0.120/0.120	0.120/0.120/0.120	0.135/0.135/0.135	0.195/0.195/0.195	0.215/0.215/0.215	0.225/0.225/0.225	
	Heating kW	0.070/0.070/0.070	0.070/0.070/0.070	0.070/0.070/0.070	0.070/0.070/0.070	0.100/0.100/0.100	0.120/0.120/0.120	0.120/0.120/0.120	0.135/0.135/0.135	0.200/0.200/0.200	0.210/0.210/0.210	0.225/0.225/0.225	
Running amperes	Cooling A	0.60/0.57/0.56	0.60/0.57/0.56	0.60/0.57/0.56	0.60/0.57/0.56	0.77/0.74/0.71	0.91/0.89/0.87	0.91/0.89/0.87	0.99/0.97/0.95	1.35/1.30/1.27	1.48/1.44/1.39	1.55/1.50/1.47	
	Heating A	0.60/0.57/0.56	0.60/0.57/0.56	0.60/0.57/0.56	0.60/0.57/0.56	0.77/0.74/0.71	0.91/0.89/0.87	0.91/0.89/0.87	0.99/0.97/0.95	1.37/1.34/1.29	1.46/1.42/1.38	1.55/1.50/1.46	
Fan motor	Type	Sirocco fan											
	Air flow rate (H/M/L)	Sirocco fan											
	m <sup>3</sup> /h	840/780/600	840/780/600	840/780/600	840/780/600	960/900/720	1,260/1,140/900	1,260/1,140/900	1,500/1,380/1,140	1,920/1,620/1,320	2,040/1,740/1,380	2,160/1,860/1,500	
	L/s	233/217/167	233/217/167	233/217/167	233/217/167	267/250/220	350/317/250	350/317/250	417/383/317	533/450/367	567/483/383	600/517/417	
Output	kW												
		0.119	0.119	0.119	0.119	0.119	0.124	0.124	0.124	0.235	0.235	0.235	
External static pressure	Pa	70(10-150)											
Power sound level (H/M/L)	dB(A)	55/51/47	55/51/47	55/51/47	55/51/47	56/54/50	57/54/48	57/54/48	59/56/50	60/56/53	61/57/54	62/58/55	
Sound pressure sound (H/M/L)	dB(A)	33/29/25	33/29/25	33/29/25	34/32/28	34/32/28	35/32/26	35/32/26	37/34/28	38/34/31	39/35/32	40/36/33	
Dimensions	H x W x D	mm											
		290x800x700	290x800x700	290x800x700	290x800x700	290x800x700	290x1,000x700	290x1,000x700	290x1,000x700	290x1,400x700	290x1,400x700	290x1,400x700	
Pipe connections	Liquid	mm (inches)											
		Ø6.35 (Ø1/4)	Ø6.35 (Ø1/4)	Ø6.35 (Ø1/4)	Ø6.35 (Ø1/4)	Ø6.35 (Ø1/4)	Ø6.35 (Ø1/4)	Ø6.35 (Ø1/4)	Ø9.52 (Ø3/8)	Ø9.52 (Ø3/8)	Ø9.52 (Ø3/8)	Ø9.52 (Ø3/8)	
	Gas	mm (inches)											
		Ø12.7 (Ø1/2)	Ø12.7 (Ø1/2)	Ø12.7 (Ø1/2)	Ø12.7 (Ø1/2)	Ø12.7 (Ø1/2)	Ø12.7 (Ø1/2)	Ø15.88 (Ø5/8)	Ø15.88 (Ø5/8)	Ø15.88 (Ø5/8)	Ø15.88 (Ø5/8)	Ø15.88 (Ø5/8)	
	Drain piping	VP-25											
Net weight	kg	29	29	29	29	29	34	34	34	46	46	46	

GLOBAL REMARKS	Rated conditions:	
	Cooling	Heating
	Indoor air temperature	27°C DB / 19°C WB
Outdoor air temperature	35°C DB / 24°C WB	7°C DB / 6°C WB

Specifications are subject to change without notice.

## F2 TYPE MID STATIC DUCTED Dimensions

### SIZE 22-56 MF2E5A

- 1 Refrigerant piping joint (liquid tube) Ø6.35 Flare
- 2 Refrigerant piping joint (gas tube) Ø12.7 Flare
- 3 Upper drain port VP25 (O.D. Ø32 mm)
- 4 Bottom drain port VP25 (O.D. Ø32 mm)
- 5 Suspension lug (4-12 x 30 mm)
- 6 Power supply outlet
- 7 Fresh air intake port (Ø150 mm)
- 8 Flange for flexible air outlet duct
- 9 Electrical component box

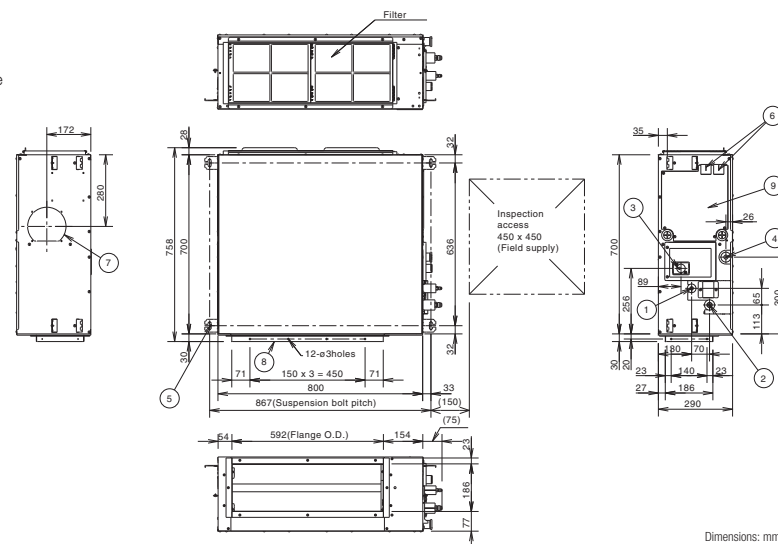

Dimensions: mm

### SIZE 60-90 MF2E5A

- 1 Refrigerant piping joint (liquid tube) Ø9.52 Flare
- 2 Refrigerant piping joint (gas tube) Ø15.88 Flare
- 3 Upper drain port VP25 (O.D. Ø32 mm)
- 4 Bottom drain port VP25 (O.D. Ø32 mm)
- 5 Suspension lug (4-12 x 30 mm)
- 6 Power supply outlet
- 7 Fresh air intake port (Ø150 mm)
- 8 Flange for flexible air outlet duct
- 9 Electrical component box

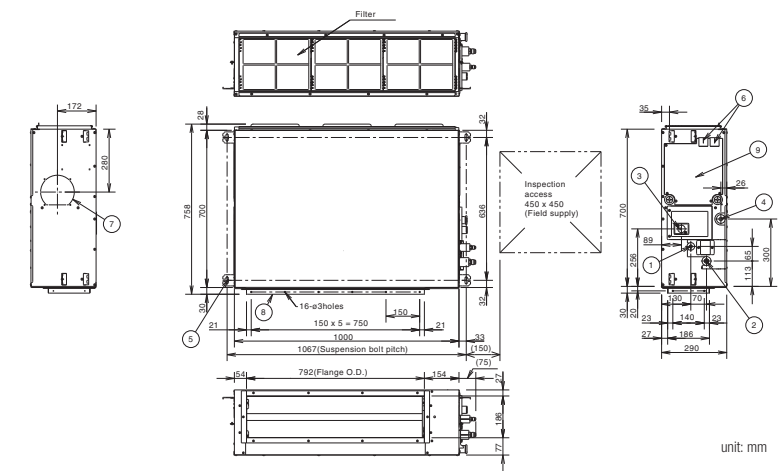

unit: mm

### SIZE 106-160 MF2E5A

- 1 Refrigerant piping joint (liquid tube) Ø9.52 Flare
- 2 Refrigerant piping joint (gas tube) Ø15.88 Flare
- 3 Upper drain port VP25 (O.D. Ø32 mm)
- 4 Bottom drain port VP25 (O.D. Ø32 mm)
- 5 Suspension lug (4-12 x 30 mm)
- 6 Power supply outlet
- 7 Fresh air intake port (Ø150 mm)
- 8 Flange for flexible air outlet duct
- 9 Electrical component box

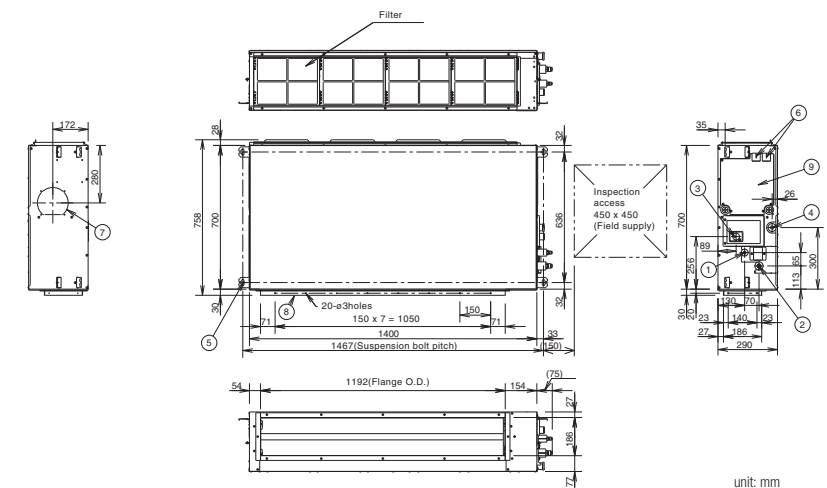

unit: mm

# M1<sub>TYPE</sub> Slim Low Static Ducted Concealed duct



The ultra slim M1 type is one of the leading products of its type in the industry. With a height of only 200 mm, it provides greater flexibility and adaptability for various applications. In addition, high efficiency and extreme low noise level make it highly suitable for hotels and small offices.



S-22MM1E5A / S-28MM1E5A / S-36MM1E5A  
S-45MM1E5A / S-56MM1E5A

**ECONAVI**  
ECONAVI ready



CZ-CENS1 CZ-RTC5



Self-diagnosing Function



Automatic Fan Operation



Mild dry



Automatic Restart Function



Built-in Drain Pump

## Technical focus

- Ultra-slim profile: 200 mm for all models
- DC fan motor greatly reduces power consumption
- Ideal for hotel application with very narrow false ceilings
- Anti-mould washable filters included
- Easy maintenance and service by external electrical box
- 40 Pa static pressure enables ductwork to be fitted.
- Includes drain pump

## Ultra-slim profile for all models

200mm height for all models allows installation in very narrow ceilings.



## Drain pump with increased power!

Using the built-in high-lift drain pump, the drain piping rise height can be increased to 653 mm from the lower surface of the body.

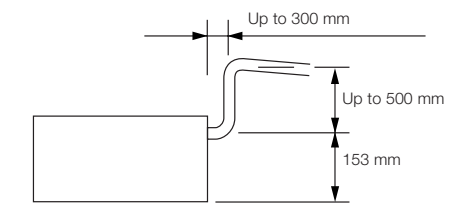

Model Name		S-22MM1E5A	S-28MM1E5A	S-36MM1E5A	S-45MM1E5A	S-56MM1E5A	
Power source		220/230/240 V, 1 phase - 50 / 60 Hz					
Cooling capacity	kW	2.2	2.8	3.6	4.5	5.6	
	BTU/h	7,500	9,600	12,000	15,000	19,000	
Heating capacity	kW	2.5	3.2	4.2	5.0	6.3	
	BTU/h	8,500	11,000	14,000	17,000	21,000	
Power input	Cooling kW	0.036/0.036/0.036	0.040/0.040/0.040	0.042/0.042/0.042	0.049/0.049/0.049	0.064/0.064/0.064	
	Heating kW	0.026/0.026/0.026	0.030/0.030/0.030	0.032/0.032/0.032	0.039/0.039/0.039	0.054/0.054/0.054	
Running current	Cooling A	0.26/0.26/0.26	0.30/0.30/0.30	0.31/0.31/0.31	0.37/0.37/0.37	0.48/0.48/0.48	
	Heating A	0.23/0.23/0.23	0.27/0.27/0.27	0.28/0.28/0.28	0.34/0.34/0.34	0.45/0.45/0.45	
Fan	Type	Sirocco fan					
	Air flow rate (H/M/L)	m <sup>3</sup> /h	480/420/360	510/450/390	540/480/420	630/570/480	750/690/600
		L/s	133/117/100	142/125/108	150/133/117	175/158/133	208/192/167
	Motor output	kW 0.05					
	External static pressure	Pa 10 (30) 15 (30) 15 (40) 15 (40) 15 (40)					
Sound power level (H/M/L)	dB	43/42/40	45/44/42	47/45/43	49/47/45	52/50/48	
Sound pressure level (H/M/L)	dB(A)	28/27/25 (30/29/27)*	30/29/27 (32/31/29)*	32/30/28 (34/32/30)*	34/32/30 (36/34/32)*	35/33/31 (37/35/32)*	
Dimensions	H x W x D	mm 200 x 750 x 640					
		Liquid mm (inches) Ø6.35 (Ø1/4) Ø6.35 (Ø1/4) Ø6.35 (Ø1/4) Ø6.35 (Ø1/4) Ø6.35 (Ø1/4)					
Pipe connections	Gas	mm (inches) Ø12.7 (Ø1/2) Ø12.7 (Ø1/2) Ø12.7 (Ø1/2) Ø12.7 (Ø1/2) Ø12.7 (Ø1/2)					
	Drain piping	VP-20 VP-20 VP-20 VP-20 VP-20					
Net weight	kg	19					

Specifications are subject to change without notice. \* With booster cable.

GLOBAL REMARKS	Rated conditions:	Cooling	Heating
	Indoor air temperature	27°C DB / 19°C WB	20°C DB
	Outdoor air temperature	35°C DB / 24°C WB	7°C DB / 6°C WB

## M1 TYPE SLIM LOW STATIC DUCTED Dimensions

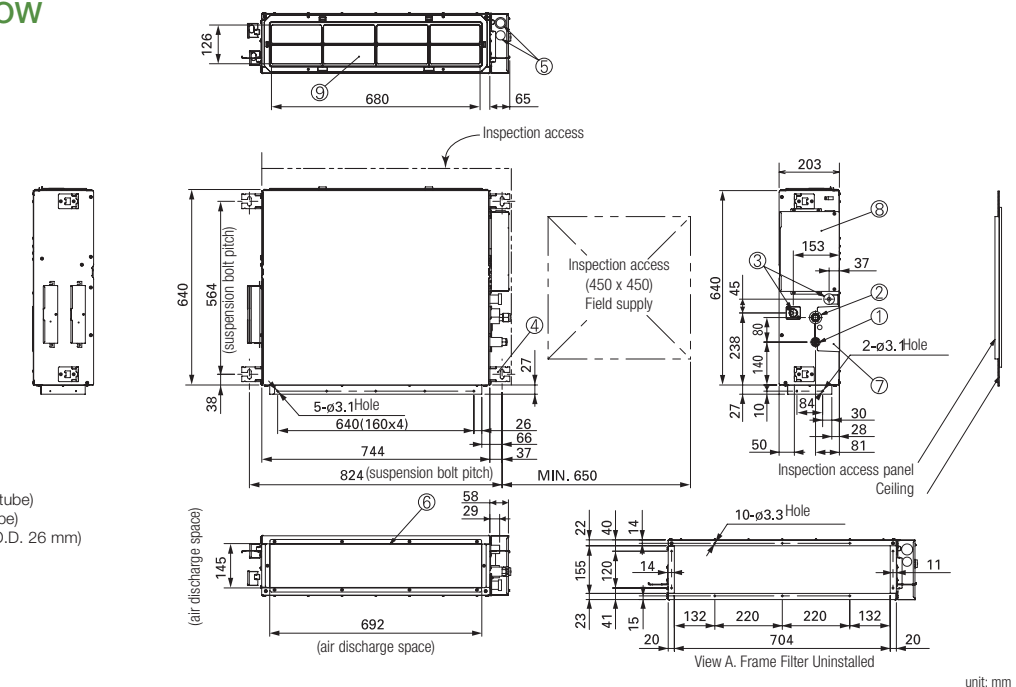

- 1 Refrigerant piping joint (narrow tube)
- 2 Refrigerant piping joint (wide tube)
- 3 Upper and bottom drain port (O.D. 26 mm)
- 4 Suspension lug
- 5 Power supply outlet (2- Ø30)
- 6 Flange for air intake duct
- 7 PI cover
- 8 Electrical component box
- 9 Frame filter

unit: mm

# Z1 TYPE Slim Low Static Ducted Twenty Series Concealed duct

The ultra slim Z1 type is one of the leading products of its type in the industry. With a height of only 200 mm, it provides greater flexibility and adaptability for various applications. In addition, high efficiency and extreme low noise level make it highly suitable for hotels and small offices.

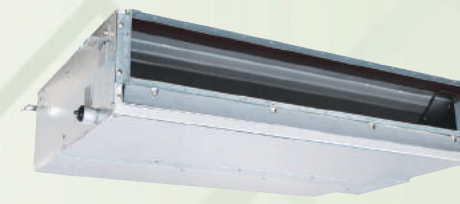

S-22MZ1H4A/ S-28MZ1H4A/ S-36MZ1H4A/  
S-45MZ1H4A/ S-56MZ1H4A/ S-60MZ1H4A

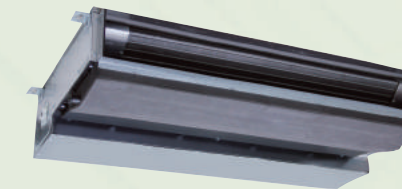

S-73MZ1H4A



CZ-CENSC1 CZ-RTC5



Self-diagnosing Function



Automatic Fan Operation



Mild dry



Automatic Restart Function

## Technical focus

- Ultra-slim profile: 200 mm for all models
- DC fan motor greatly reduces power consumption
- Ideal for hotel application with very narrow false ceilings
- Easy maintenance and service by external electrical box
- 29 Pa static pressure enables ductwork to be fitted.
- Drain pump (optional)

## Ultra-slim profile for all models

200mm height for all models allows installation in very narrow ceilings.

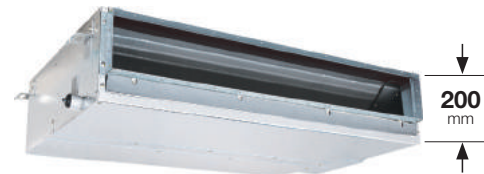

## Drain pump with increased power! (optional)

Using the optional high-lift drain pump, the drain piping rise height can be increased to 700 mm from the drain pipe port.

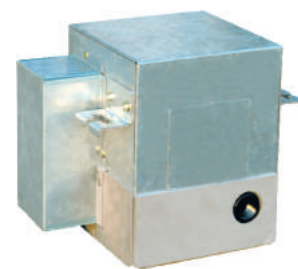

CZ-73DMZ1

Model Name		S-22MZ1H4A	S-28MZ1H4A	S-36MZ1H4A	S-45MZ1H4A	S-56MZ1H4A	S-60MZ1H4A	S-73MZ1H4A	
Power source		220/230/240 V, 1 phase - 50 / 60 Hz							
Cooling capacity	kW	2.2	2.8	3.6	4.5	5.6	6.0	7.3	
	BTU/h	7,500	9,500	12,200	15,300	19,100	20,500	24,900	
Heating capacity	kW	2.5	3.2	4.2	5.1	6.4	7.1	8.0	
	BTU/h	8,500	10,900	14,300	17,400	21,800	24,200	27,300	
Power input	Cooling kW	0.075/0.075/0.075	0.080/0.080/0.080	0.085/0.085/0.085	0.095/0.095/0.095	0.100/0.100/0.100	0.100/0.100/0.100	0.125/0.125/0.125	
	Heating kW	0.075/0.075/0.075	0.080/0.080/0.080	0.085/0.085/0.085	0.095/0.095/0.095	0.100/0.100/0.100	0.100/0.100/0.100	0.125/0.125/0.125	
Running current	Cooling A	0.50/0.47/0.45	0.55/0.52/0.50	0.60/0.57/0.55	0.70/0.68/0.65	0.75/0.72/0.70	0.75/0.72/0.70	0.80/0.78/0.75	
	Heating A	0.50/0.47/0.45	0.55/0.52/0.50	0.60/0.57/0.55	0.70/0.68/0.65	0.75/0.72/0.70	0.75/0.72/0.70	0.80/0.78/0.75	
Fan	Type	Sirroco fan							
	Air flow rate (H/M/L)	m <sup>3</sup> /h	480/420/360	600/540/420	600/540/420	690/630/510	720/660/540	870/750/630	1,080/840/660
		L/s	133/117/100	167/150/117	167/150/117	192/175/142	200/183/150	242/208/175	300/233/183
	Motor output	kW	60	60	60	60	60	60	60
	External static pressure	Pa	10-30	10-30	10-30	10-30	10-30	10-30	10-30
	Sound power level (H/M/L)	dB	50/49/47	52/51/49	54/52/50	56/54/52	57/55/53	60/57/55	62/60/58
Sound pressure level (H/M/L)	dB(A)	28/27/25	30/29/27	32/30/28	34/32/30	35/33/31	38/35/33	40/38/36	
	Dimensions	H x W x D	mm	200x830x500	200x830x500	200x830x500	200x830x500	200x830x500	200x1,050x550
Pipe connections	Liquid	mm (inches)	Ø6.35 (Ø1/4)	Ø6.35 (Ø1/4)	Ø6.35 (Ø1/4)	Ø6.35 (Ø1/4)	Ø6.35 (Ø1/4)	Ø9.52 (Ø3/8)	
	Gas	mm (inches)	Ø12.7 (Ø1/2)	Ø12.7 (Ø1/2)	Ø12.7 (Ø1/2)	Ø12.7 (Ø1/2)	Ø12.7 (Ø1/2)	Ø15.88 (Ø5/8)	
	Drain piping		O.D. Ø20.5 mm / I.D. Ø15.5mm	O.D. Ø20.5 mm / I.D. Ø15.5mm	O.D. Ø20.5 mm / I.D. Ø15.5mm	O.D. Ø20.5 mm / I.D. Ø15.5mm	O.D. Ø20.5 mm / I.D. Ø15.5mm	O.D. Ø20.5 mm / I.D. Ø15.5mm	
Net weight	kg	17	17	18	18	18	18	24	

GLOBAL REMARKS	Rated conditions:	
	Cooling	Heating
	Indoor air temperature 27°C DB / 19°C WB	20°C DB
	Outdoor air temperature 35°C DB / 24°C WB	7°C DB / 6°C WB

Specifications are subject to change without notice.

## Z1 TYPE SLIM LOW STATIC DUCTED TWENTY SERIES Dimensions

### SIZE 22-60MZ1H4A

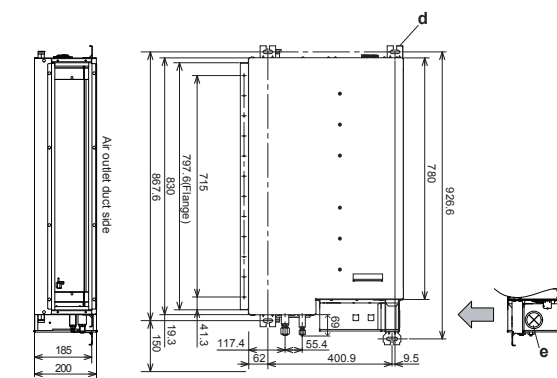

### SIZE 73MZ1H4A

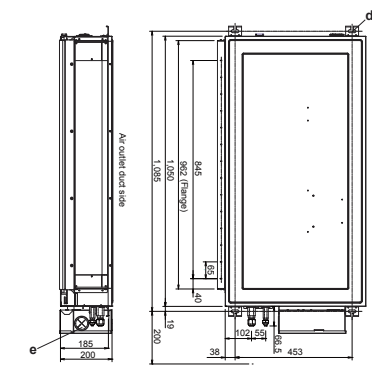

- a) Refrigerant tubing joint (liquid tube)
- b) Refrigerant tubing joint (gas tube)
- c) Bottom drain port O.D.Ø20.5 mm / I.D. Ø15.5mm
- d) Suspension lug (4 – 12 x 30 mm)
- e) Power supply outlet
- f) Flange for flexible air outlet duct
- g) Electrical component box

unit: mm

# E2 TYPE High Static Ducted

## Concealed duct / Air conditioning mode



High static and large airflow ducted for exceptional installation flexibility.



CZ-RTC5

S-180ME2E5 / S-224ME2E5 / S-280ME2E5



Self-diagnosing Function



Automatic Fan Operation



Mild dry



Automatic Restart Function

### Technical focus

- Design flexibility thanks to high static pressure and large air volume
- DC motor equipped
- Power input 45% less (compared to E1 type)
- Discharge air temperature control to reduce cold drafts during heating operation
- Configurable air temperature control
- Available Fresh Air Intake mode (See page 80-81)

### 3-step static pressure set up

You can select between the three Static Pressure modes of 270 Pa/140 Pa/60(72\*) Pa for extra installation flexibility.



\* 28 kW model

### Max. 270 Pa static pressure setting

A maximum static pressure setting of a high 270 Pa enables the use of long ducts for installation in a wide range of spaces. Ideal for large-scale offices, restaurants and other facilities.

### Sensible cooling 5-10% improved

New heat exchanger with  $\phi 7$ mm pipe that increases the heat transfer surface to improve sensible cooling (5-10% improvement)

### No Rap Valve Kit required

Thanks to improved performance, a Rap Valve Kit (CZ-P160RVK2) is no longer required.



### Discharge air temperature control

- Equipped with 4 sensors (Intake/ Discharge)
- Able to control discharge air temperature for accurate room temperature control.
- Possible to reduce cold drafts during heating operation.

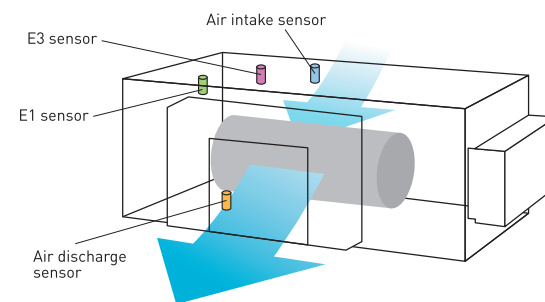

Model Name	S-180ME2E5	S-224ME2E5	S-280ME2E5		
Power source	220/230/240 V, 1 phase - 50/60Hz				
Cooling capacity	kW	18.0	22.4	28.0	
	BTU/h	61,400	76,400	95,500	
Heating capacity	kW	20.0	25.0	31.5	
	BTU/h	68,200	85,300	107,500	
Power input	Cooling kW	0.400	0.440	0.715	
	Heating kW	0.400	0.440	0.715	
Running current	Cooling A	2.40 / 2.30 / 2.20	2.55 / 2.45 / 2.35	3.95 / 3.85 / 3.70	
	Heating A	2.40 / 2.30 / 2.20	2.55 / 2.45 / 2.35	3.95 / 3.85 / 3.70	
Fan	Type	Sirocco fan			
	Air flow rate (H/M/L)	m <sup>3</sup> /h	2,940 / 2,640 / 2,340	3,360 / 3,060 / 2,640	4,320 / 3,780 / 3,180
		L/s	816 / 733 / 650	933 / 850 / 733	1,200 / 1,050 / 883
	External static pressure	Pa	140 (60/270)	140 (60/270)	140 (72/270)
Sound power level (H/M/L)	dB	76 / 74 / 72	77 / 75 / 73	81 / 79 / 75	
Sound pressure level (H/M/L)	dB(A)	44 / 42 / 40	45 / 43 / 41	49 / 47 / 43	
Dimensions	H x W x D	mm 479 x 1,453 x 1,205			
	Pipe connections	Liquid	inches (mm) $\phi 9.52$ (3/8)	$\phi 9.52$ (3/8)	$\phi 9.52$ (3/8)
Pipe connections	Gas	inches (mm)	$\phi 19.05$ (3/4)	$\phi 19.05$ (3/4)	$\phi 22.22$ (7/8)
	Drain piping		VP-25	VP-25	VP-25
Net weight	kg	102	102	106	

GLOBAL REMARKS	Rated conditions:	
	Cooling	Heating
	Indoor air temperature 27°C DB / 19°C WB	20°C DB
Outdoor air temperature 35°C DB / 24°C WB	7°C DB / 6°C WB	

### E2 TYPE HIGH STATIC DUCTED Dimensions

- 1 Refrigerant piping (liquid pipes)  $\phi 9.52$
- 2 Refrigerant piping (gas pipes) 180 & 224 type:  $\phi 19.05$ , 280 type:  $\phi 22.22$
- 3 Power supply outlet ( $\phi 25$  grommet, rubber)
- 4 Power supply outlet (spare) ( $\phi 30$  knock-out)
- 5 Optional outlet for piping
- 6 Drain port 25 A, male thread
- 7 Duct connection for suction
- 8 Duct connection for discharge

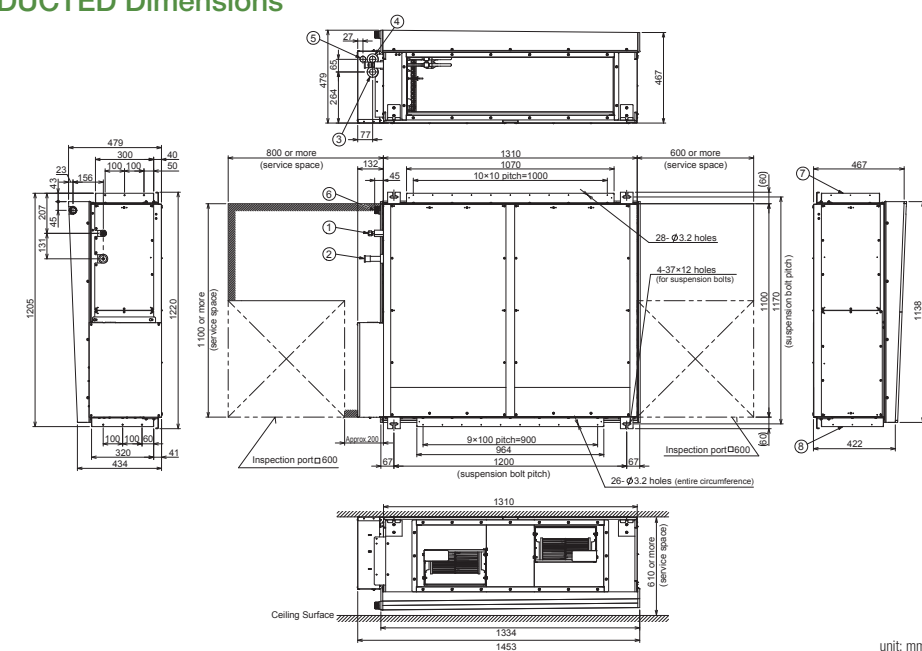

unit: mm



# E2 TYPE Energy Saving High Fresh Air Ducted

## Concealed duct high-static pressure



High static and large airflow ducted for exceptional installation flexibility.



S-224ME2E5 / S-280ME2E5



CZ-RTC5



Self-diagnosing Function



Automatic Fan Operation



Automatic Restart Function

### Technical focus

- 100% fresh air intake for ventilation purpose
- Design flexibility with high static pressure and large air volume
- DC motor equipped
- Power input 45% less (compared to H1 type)
- Discharge air temperature control to reduce cold drafts during heating operation
- Configurable air temperature control

### High Fresh System

High Fresh System enables delivery of fresh outside air at almost the same temperature and humidity as indoor air without putting a burden on air conditioning.

\* Capable of treating outdoor air only. Indoor air conditioner units are required to adjust indoor air temperature.

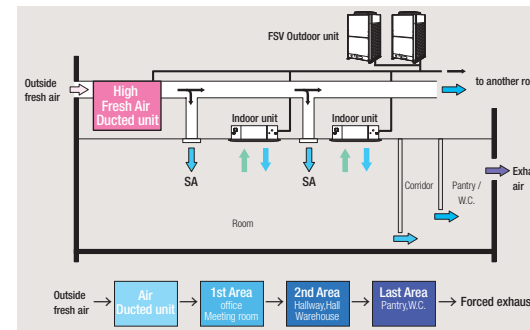

### Mix operation unit with standard indoor units

Possible to combine High Fresh Air ducted indoor unit and standard air ducted indoor units. When other indoor units are connected in same circuit, keep following capacity ratio. E2 type/Outdoor unit < 30%, and Total of indoors(incl. E2)/outdoor < 100%

### Discharge air temperature control

- Equipped with 4 sensors (Intake/ Discharge)
- Able to control discharge air temperature for accurate room temperature control.
- Possible to reduce cold drafts during heating operation.

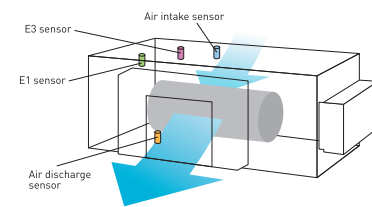

### Remark For High Static Ducted Series

Model	Operation	Rap valve kit CZ-P160RVK2	3way control PCB CZ-CAPE2	3way valve kit CZ-P160HR3	Distribution Joint kit <2pipes> CZ-P160BK2 for 22.4kW unit	Distribution Joint kit <3pipes> CZ-P224BH2 for 22.4kW unit CZ-P680BH2 for 28.0kW unit
E2 Type Energy Saving High-Fresh Air Ducted	Cooling Only	-	-	-	-	-
	Cool or Heat	2pcs	2pcs	-	2pcs	-
	Heat Recovery	-	2pcs	2pcs	1pc	1pc

Model Name	S-224ME2E5		S-280ME2E5	
Power source	220/230/240 V, 1 phase - 50/60Hz			
Outdoor temperature condition	Cooling:22°C~46°C, Heating:-5°C~16°C, Cooling & Heating:-5°C~-24°C			
Cooling capacity	kW	22.4	28.0	
	BTU/h	76,400	95,500	
Heating capacity	kW	21.2	26.5	
	BTU/h	72,200	90,400	
Power input	Cooling kW	0.290	0.350	
	Heating kW	0.290	0.350	
Running current	Cooling A	1.80	2.10	
	Heating A	1.80	2.10	
Fan	Type	Sirocco fan		Sirocco fan
	Air flow rate	m³/h	1,700	2,100
		L/s	472	583
	Motor output	kW	-	-
	External static pressure	Pa	200	200
Sound power level	dB	75	76	
Sound pressure level	dB(A)	43	44	
Dimensions	H x W x D	mm	479 x 1,453 x 1,205	479 x 1,453 x 1,205
	Liquid	inches (mm)	Ø9.52 (Ø3/8)	Ø9.52 (Ø3/8)
Pipe connections	Gas	inches (mm)	Ø19.05 (Ø3/4)	Ø22.22 (Ø7/8)
	Drain piping		VP-25	VP-25
Net weight	kg	102	106	

GLOBAL REMARKS: Rated conditions: Cooling 33°C DB / 28°C WB, Heating 0°C DB / -2.9°C WB. Specifications are subject to change without notice.

### E2 TYPE HIGH STATIC DUCTED Dimensions

- 1 Refrigerant piping (liquid pipes) Ø9.52
- 2 Refrigerant piping (gas pipes) 224 type: Ø19.05, 280 type: Ø22.22
- 3 Power supply outlet (Ø25 grommet, rubber)
- 4 Power supply outlet (spare) (Ø30 knock-out)
- 5 Optional outlet for piping
- 6 Drain port 25 A, male thread
- 7 Duct connection for suction
- 8 Duct connection for discharge

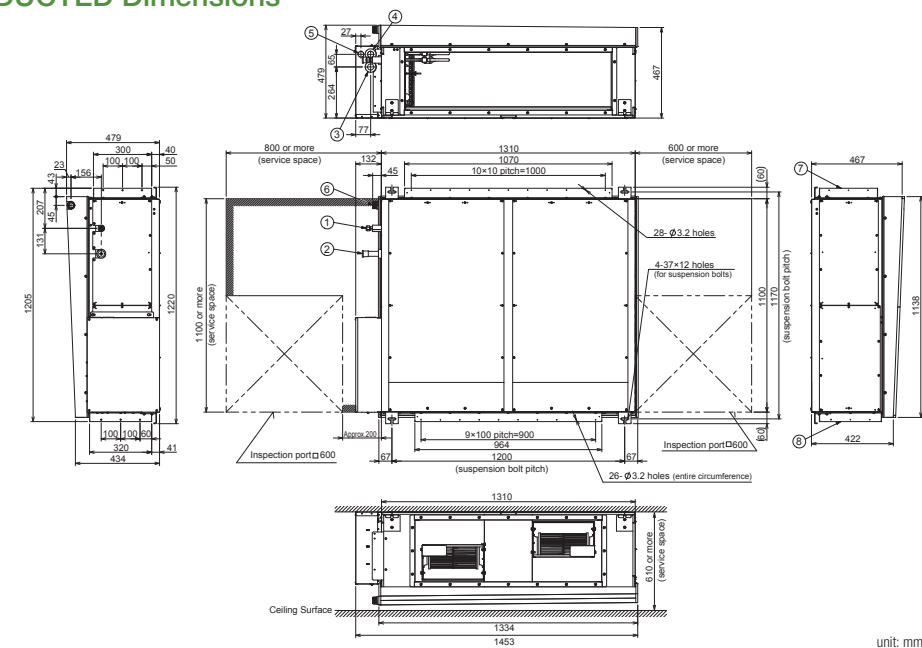

# E1 TYPE High Static Ducted

## Concealed duct high-static pressure

The E1 range of ducted units offers improved design flexibility for extended duct layouts as a result of their increased external static pressures.

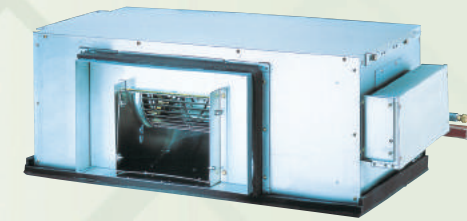

S-73ME1E5/  
S106ME1E5/  
S-140MH1E5



S-224ME1E5 /  
S-280ME1E5



CZ-RTCS



Self-diagnosing Function



Automatic Fan Operation



Mild dry



Automatic Restart Function

### Technical focus

- Complete flexibility for ductwork design
- Can be located into a weatherproof housing for external installation
- Discharge air temperature control to reduce cold drafts during heating operation
- Configurable air temperature control

### System example

An inspection port (450 x 450 mm or more) is required at the lower side of the indoor unit body (field supply).

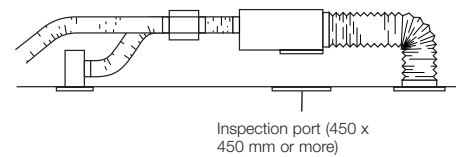

### Discharge air temperature control

- Equipped with 4 sensors (Intake/ Discharge)
- Able to control discharge air temperature for accurate room temperature control.
- Possible to reduce cold drafts during heating operation.

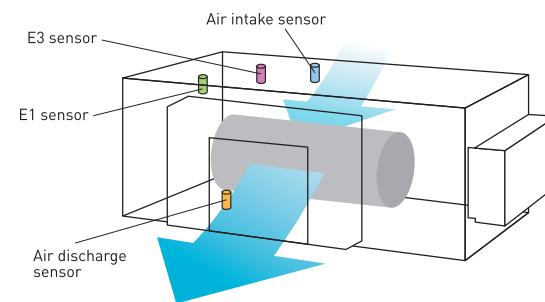

### Remark For High Static Ducted Series

Model	Operation	Rap valve kit CZ-P160RVK2	3way control PCB CZ-CAPE2	3way valve kit CZ-P160HR3	Distribution Joint kit <2pipes> CZ-P160BK2 for 22.4kW unit	Distribution Joint kit <3pipes> CZ-P224BH2 for 22.4kW unit CZ-P680BH2 for 28.0kW unit
E1 Type High Static Ducted (Only for S-224,S-280)	Cooling Only	-	-	-	-	-
	Cool or Heat	2pcs	-	-	2pcs	-
	Heat Recovery	-	-	2pcs	1pc	1pc

Model Name		S-73ME1E5	S-106ME1E5	S-140ME1E5	S-224ME1E5	S-280ME1E5
Power source		220/230/240 V, 1 phase - 50 / 60 Hz				220/230/240 V, 1 phase - 50 Hz
Cooling capacity	kW	7.3	10.6	14.0	22.4	28.0
	BTU/h	25,000	36,000	47,800	76,400	95,500
Heating capacity	kW	8.0	11.4	16.0	25.0	31.5
	BTU/h	27,000	39,000	54,600	85,300	107,500
Power input	Cooling kW	0.480/0.505/0.530	0.520/0.545/0.570	0.600/0.660/0.710	0.870/0.900/0.930	1.270/1.330/1.390
	Heating kW	0.480/0.505/0.530	0.520/0.545/0.570	0.600/0.660/0.710	0.870/0.900/0.930	1.270/1.330/1.390
Running current	Cooling A	2.29/2.30/2.31	2.46/2.46/2.47	2.80/2.90/3.00	4.05/4.06/4.07	6.04/6.06/6.07
	Heating A	2.29/2.30/2.31	2.46/2.46/2.47	2.80/2.90/3.00	4.05/4.06/4.07	6.04/6.06/6.07
Fan	Type	Sirocco fan	Sirocco fan	Sirocco fan	Sirocco fan	Sirocco fan
	Air flow rate (H/M/L)	m³/h 1,380/1,320/1,260	1,800/1,680/1,500	2,160/2,100/1,980	3,360/3,190/2,980	4,320/4,200/3,960
	L/s	383/367/350	500/467/417	600/583/550	933/886/828	1,200/1,167/1,100
	Motor output kW	0.2	0.2	0.35	0.2	0.4
External static pressure	Pa	186	176	167	176	216 (235)*
Sound power level (H/M/L)	dB	55/54/53	56/55/53	58/57/55	59/58/57	62/61/60
Sound pressure level (H/M/L)	dB(A)	44/43/42	45/44/42	47/46/44	48/47/46	51/50/49 (52/51/50)*
Dimensions H x W x D	mm	420 x 1,065 x 620	420 x 1,065 x 620	450 x 1,065 x 620	479 x 1,428 x 1,230	479 x 1,428 x 1,230
	Liquid mm (inches)	Ø9.52 (Ø3/8)	Ø9.52 (Ø3/8)	Ø9.52 (Ø3/8)	Ø9.52 (Ø3/8)	Ø9.52 (Ø3/8)
Pipe connections	Gas mm (inches)	Ø15.88 (Ø5/8)	Ø15.88 (Ø5/8)	Ø15.88 (Ø5/8)	Ø19.05 (Ø3/4)	Ø22.22 (Ø7/8)
	Drain piping	VP-25	VP-25	VP-25	VP-25	VP-25
Net weight	kg	47	50	54	110	120

GLOBAL REMARKS	Rated conditions:		Specifications are subject to be changed without notice. * Via Jumper setting.
	Cooling	Heating	
	Indoor air temperature	27°C DB / 19°C WB	
Outdoor air temperature	35°C DB / 24°C WB	7°C DB / 6°C WB	

### E1 TYPE HIGH STATIC DUCTED Dimensions

#### SIZE 73-140

- 1 Refrigerant liquid line (ø9.52)
- 2 Refrigerant gas line (ø15.88)
- 3 Power supply entry
- 4 Drain connection (20A / VP25)
- 5 Duct connection for suction
- 6 Duct connection for discharge

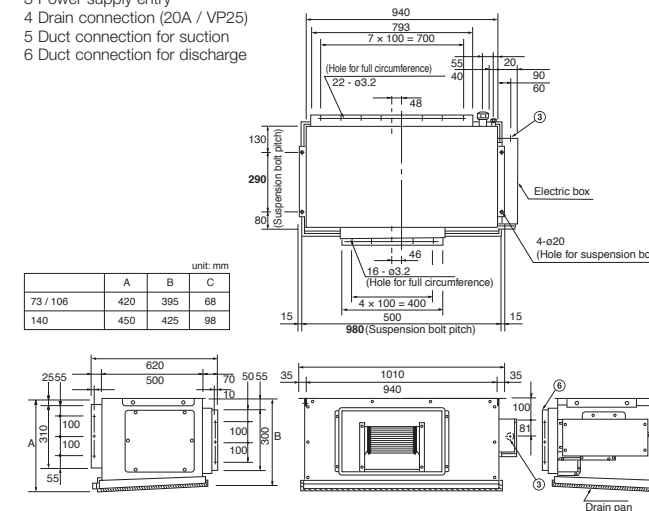

#### SIZE 224-280

- 1 Refrigerant piping (liquid pipes) Ø9.52
- 2 Refrigerant piping (gas pipes) 224 type: Ø19.05, 280 type: Ø22.22
- 3 Power supply outlet (Ø25 grommet, rubber)
- 4 Power supply outlet (spare) (Ø30 knock-out)
- 5 Drain port 25 A, male thread
- 6 Duct connection for suction
- 7 Duct connection for discharge

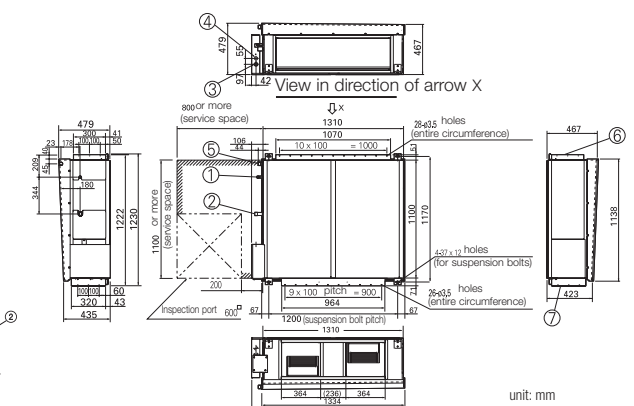

# H1 TYPE High-Fresh Air Ducted Concealed duct

High static and large airflow ducted for exceptional installation flexibility.

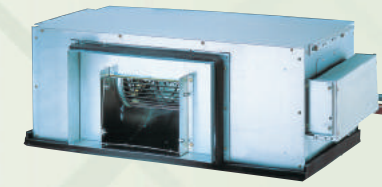

S-140MH1H5



S-224MH1H5  
S-280MH1H5



CZ-RTC5



Self-diagnosing Function



Automatic Fan Operation



Automatic Restart Function

## Technical focus

- 100% fresh Air intake for ventilation purpose
- Design flexibility thanks to high static pressure and large air volume
- Discharge air temperature control to reduce cold drafts during heating operation
- Configurable air temperature control

## High Fresh System

High Fresh system enables delivery of fresh outside air at almost the same temperature and humidity as indoor air without putting a burden on air conditioning.

\* Capable of treating outdoor air only. Indoor air conditioner units are required to adjust indoor air temperature.

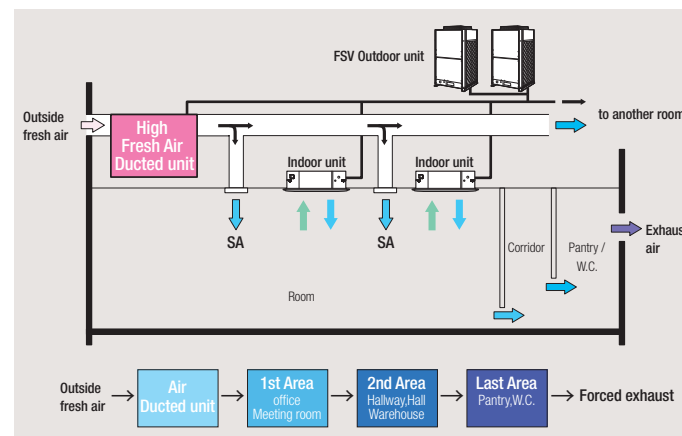

## Mix operation unit with standard indoor units

Possible to combine High Fresh Air ducted indoor unit and standard air ducted indoor units.

When other indoor units are connected in same circuit, keep following capacity ratio.  
H1 type/Outdoor unit < 30%, and Total of indoors(incl. H1)/outdoor < 100%

## Remark For High Static Ducted Series

Model	Operation	Rap valve kit CZ-P160RVK2	3way control PCB CZ-CAPE2	3way valve kit CZ-P160HR3	Distribution Joint kit <2pipes> CZ-P160BK2 for 22.4kW unit	Distribution Joint kit <3pipes> CZ-P224BH2 for 22.4kW unit CZ-P680BH2 for 28.0kW unit
H1 Type High-Fresh Air Ducted	Cooling Only	-	-	-	-	-
	Cool or Heat	2pcs	-	-	2pcs	-
	Heat Recovery	-	-	2pcs	1pc	1pc

Model Name	S-140MH1H5	S-224MH1H5	S-280MH1H5		
Power source	220/230/240 V, 1 phase - 50Hz				
Cooling capacity	kW	14.0	22.4	28.0	
	BTU/h	47,800	76,400	95,500	
Heating capacity	kW	13.2	21.2	26.5	
	BTU/h	45,000	72,300	90,400	
Power input	Cooling kW	0.430/0.430/0.430	0.670/0.670/0.670	0.730/0.730/0.730	
	Heating kW	0.430/0.430/0.430	0.670/0.670/0.670	0.730/0.730/0.730	
Running current	Cooling A	2.0/1.9/1.9	3.2/3.1/3.0	3.6/3.4/3.3	
	Heating A	2.0/1.9/1.9	3.2/3.1/3.0	3.6/3.4/3.3	
Fan	Type	Sirocco fan			
	Air flow rate m³/h	1,560	1,800	2,100	
	L/s	433	500	583	
	Motor output kW	0.2	0.4	0.4	
Sound power level (H/M/L)	dB	75/76/76	78/79/79	79/80/80	
	Sound pressure level (H/M/L) dB(A)	43/44/44	46/47/47	47/48/48	
Dimensions H x W x D mm	420 x 1,065 x 620			479 x 1,428 x 1,230	479 x 1,428 x 1,230
	Liquid mm (inches)	Ø9.52 (Ø3/8)	Ø12.7 (Ø1/2)	Ø12.7 (Ø1/2)	
Pipe connections	Gas mm (inches)	Ø15.88 (Ø5/8)	Ø25.4 (Ø1)	Ø25.4 (Ø1)	
	Drain piping	VP-25	VP-25	VP-25	
Net weight kg	50	110	110		

GLOBAL REMARKS Rated conditions: Cooling Heating Specifications are subject to change without notice.  
Outdoor air temperature 33°C DB / 28°C WB 0°C DB / -2.9°C WB

## H1TYPE HIGH-FRESH AIR DUCTED Dimensions

- 1 Refrigerant liquid line
- 2 Refrigerant gas line
- 3 Power supply entry
- 4 Drain connection
- 5 Duct connection for suction
- 6 Duct connection for discharge

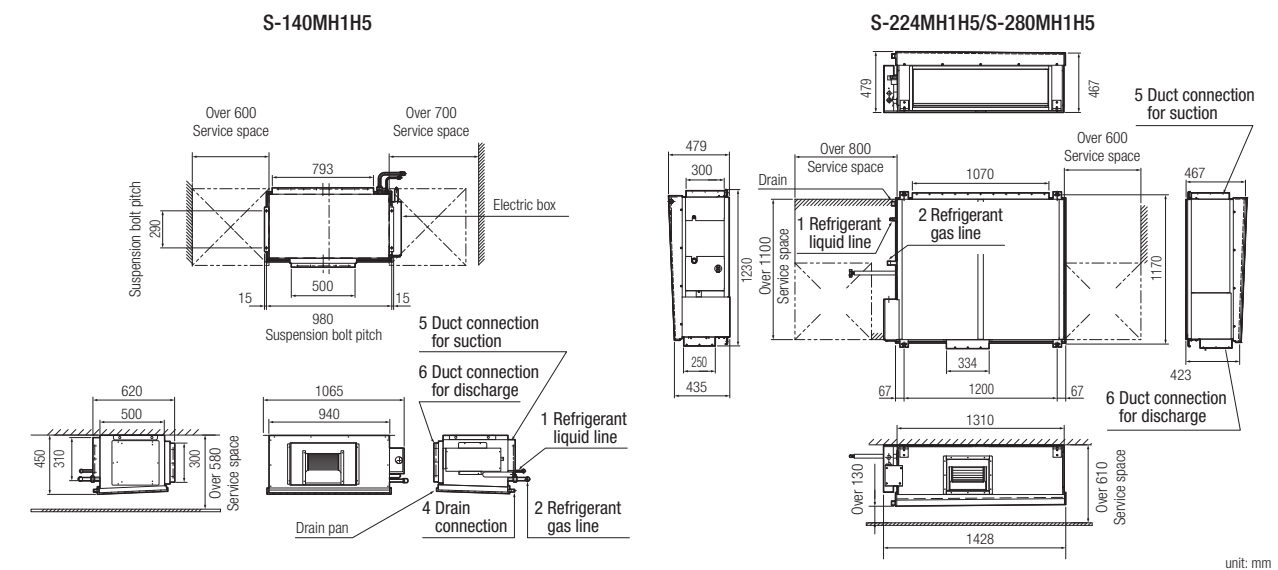

unit: mm

# K2<sub>TYPE</sub> K1<sub>TYPE</sub> Wall Mounted



**ECONAVI**  
ECONAVI ready



CZ-CENSC1 CZ-RTC5

The K2/K1 type wall mounted unit has a stylish smooth design with a washable front panel. Small, lightweight and low noise level makes it ideal for small offices and other commercial applications.



S-22MK2E5A / S-28MK2E5A / S-36MK2E5A

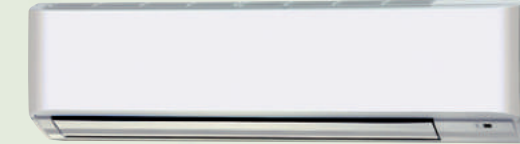

S-45MK1E5A / S-56MK1E5A / S-73MK1E5A / S-106MK1E5A



Self-diagnosing Function



Automatic Fan Operation



Mild dry



Intelligent Auto Swing



Automatic Restart Function



Auto Swing (Auto Flap Control)

## Technical focus

- Closed discharge port when not in use
- Lighter and smaller units make installation easy
- Quiet operation
- Smooth and durable design
- Piping outlet in six directions
- Washable front panel
- Air distribution is automatically altered depending on the operational mode of the unit
- Anti-mould washable filters are included

## Noise reducing external valve kit

To reduce noise level of expansion valve. (Optional accessory)



CZ-P56SVK2 (for 22 - 56 type)  
CZ-P160SVK2 (for 73 - 106 type)

## Closed discharge port

When the unit is turned off, the flap closes completely to prevent entry of dust into the unit and to keep the equipment clean.

## Compact indoor units make the installation easy

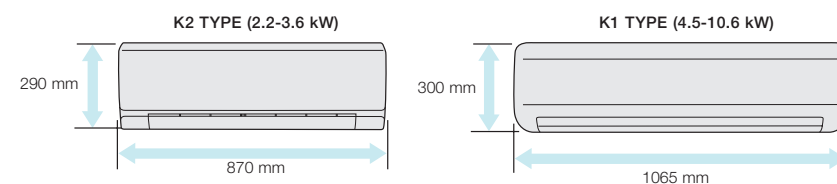

## Quiet operation

Low operating noise level makes these units ideal for hotels and hospital applications.

## Smooth and durable design

The smooth cover means these units match most modern interiors. Their compact size enables them to blend in, even in small spaces.

## Piping outlet in six directions

Piping outlet is possible in the six directions of right, right rear, right bottom, left, left rear, left bottom, making installation easier.

## Washable front panel

The indoor unit's front panel can be easily removed and washed for trouble-free maintenance.



## Air distribution is automatically adjusted depending on the operational mode of the unit

Air outlet angle is automatically adjusted for cooling and heating operation.

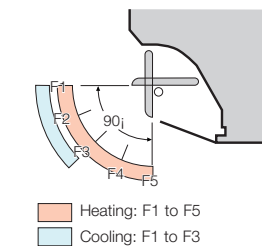

**K2** TYPE  
**K1** TYPE Wall Mounted

Model Name		S-22MK2E5A	S-28MK2E5A	S-36MK2E5A	S-45MK1E5A	S-56MK1E5A	S-73MK1E5A	S-106MK1E5A	
Power source		220/230/240 V, 1 phase - 50 / 60 Hz				220/230/240 V, 1 phase - 50 / 60 Hz			
Cooling capacity	kW	2.20	2.80	3.60	4.5	5.6	7.3	10.6	
	BTU/h	7,500	9,600	12,000	15,000	19,000	25,000	36,000	
Heating capacity	kW	2.50	3.20	4.20	5.0	6.3	8.0	11.4	
	BTU/h	8,500	11,000	14,000	17,000	21,000	27,000	39,000	
Power input	Cooling kW	0.025/0.025/0.025	0.025/-/-	0.03/0.03/0.03	0.020/0.020/0.021	0.029/0.030/0.030	0.056/0.057/0.057	0.059/0.060/0.060	
	Heating kW	0.025/0.025/0.025	0.025/-/-	0.03/0.03/0.03	0.020/0.020/0.021	0.029/0.030/0.030	0.056/0.057/0.057	0.067/0.068/0.068	
Running current	Cooling A	0.21	0.23	0.25	0.27/0.26/0.23	0.36/0.35/0.32	0.59/0.58/0.52	0.63/0.62/0.55	
	Heating A	0.21	0.23	0.25	0.27/0.26/0.23	0.36/0.35/0.32	0.59/0.58/0.52	0.70/0.70/0.62	
Fan	Type	Cross-flow fan	Cross-flow fan	Cross-flow fan	Cross-flow fan	Cross-flow fan	Cross-flow fan	Cross-flow fan	
	Air flow rate (H/M/L)	m³/h	540/450/390	570/500/390	655/540/390	720/630/510	840/720/630	1,080/870/690	1,140/990/780
		L/s	150/125/108	158/139/108	182/150/108	200/175/142	233/200/175	300/242/192	317/275/217
	Motor output	kW	0.03	0.03	0.03	0.047	0.047	0.047	0.047
Sound power level (H/M/L)	dB	51/48/44	52/49/44	55/51/44	49/45/41	58/55/51	58/55/51	60/56/53	
Sound pressure level (H/M/L)	dB(A)	36/33/29	37/34/29	40/36/29	38/34/30	40/36/32	47/44/40	49/45/42	
Dimensions	H x W x D	mm	290 x 870 x 214	290 x 870 x 214	290 x 870 x 214	300 x 1,065 x 230	300 x 1,065 x 230	300 x 1,065 x 230	
	Liquid	mm (inches)	Ø6.35 (Ø1/4)	Ø6.35 (Ø1/4)	Ø6.35 (Ø1/4)	Ø6.35 (Ø1/4)	Ø9.52 (Ø3/8)	Ø9.52 (Ø3/8)	
Pipe connections	Gas	mm (inches)	Ø12.7 (Ø1/2)	Ø12.7 (Ø1/2)	Ø12.7 (Ø1/2)	Ø12.7 (Ø1/2)	Ø15.88 (Ø5/8)	Ø15.88 (Ø5/8)	
	Drain piping	mm	Ø16	Ø16	Ø16	Ø18	Ø18	Ø18	
Net weight	kg	9	9	9	13	13	14.5	14.5	

GLOBAL REMARKS	Rated conditions:	Cooling	Heating
	Indoor air temperature	27°C DB / 19°C WB	20°C DB
	Outdoor air temperature	35°C DB / 24°C WB	7°C DB / 6°C WB

Specifications are subject to change without notice.

**K2 TYPE WALL MOUNTED Dimensions**

S-22MK2E5A / S-28MK2E5A / S-36MK2E5A

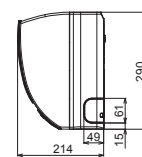
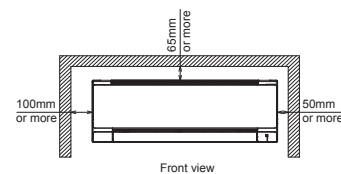
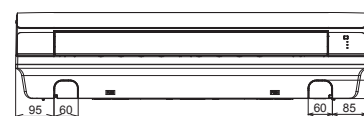
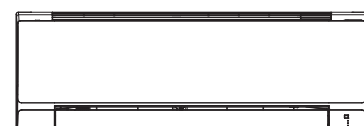
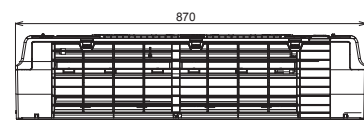

- 1 Refrigerant tubing (liquid tube) ø6.35(flared)
- 2 Refrigerant tubing (gas tube) ø12.7(flared)
- 3 Drain hose (outer dia. ø16)
- 4 Rear panel (PL BACK)
- 5 Rear panel fixing holes (ø5 holes or 5X13 oval holes)
- 6 Tubing and wiring holes (ø70)

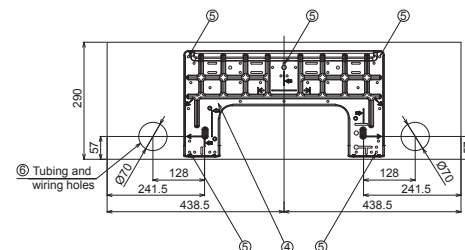
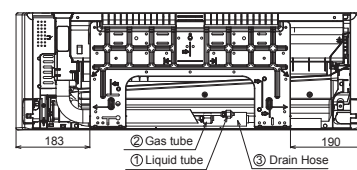

unit: mm

**K1 TYPE WALL MOUNTED Dimensions**

S-45MK1E5A / 56MK1E5A / 73MK1E5A / 106MK1E5A

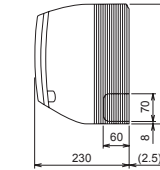
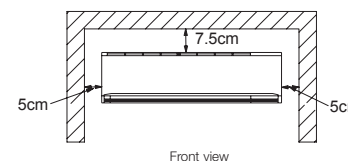
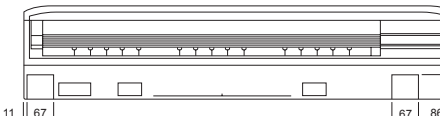
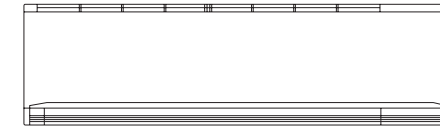
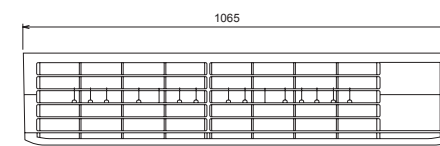

- 1 Refrigerant piping (liquid tube) 45-56 / 73-106 type ø6.35 / ø9.52 (flared)
- 2 Refrigerant piping (gas tube) 45-56 / 73-106 type ø12.7 / ø15.88 (flared)
- 3 Drain hose VP13 (outer dia. ø18)
- 4 Rear panel (PL BACK)
- 5 Tubing and wiring holes (ø80)

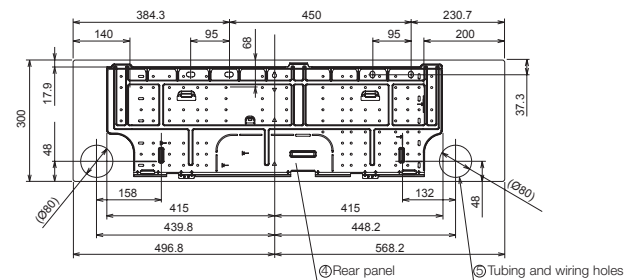
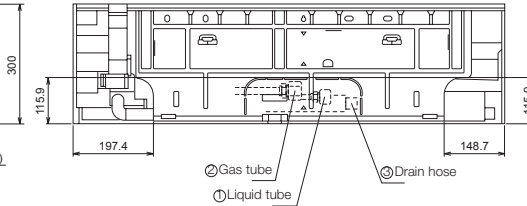

unit: mm

# U1 TYPE 4-WAY Cassette

## Semi concealed cassette



Our best selling U1 Type cassettes are made smaller, slimmer, lighter and come with a standard 950 x 950mm panel for the entire product range.

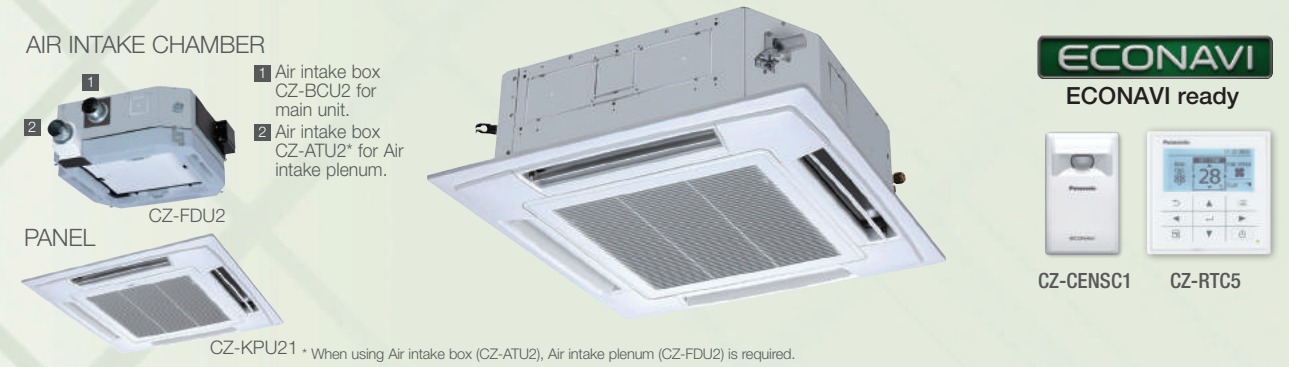

CZ-KPU21 \* When using Air intake box (CZ-ATU2), Air intake plenum (CZ-FDU2) is required.

- Self-diagnosing Function
- Automatic Fan Operation
- Mild dry
- Intelligent Auto Swing
- Automatic Restart Function
- Auto Swing (Auto Flap Control)
- Built-in Drain Pump

### Technical focus

- Compact design
- Lightweight design
- Reduced sound levels (from previous models)
- Fresh air knockout
- DC fan motor for increased efficiency
- Branch duct connection
- Powerful drain pump gives 850 mm lift
- Optional air-intake plenum CZ-FDU2

### Lighter and slimmer, easier installation

A lightweight unit at 24 kg, the unit is also very slim with a height of only 256 mm, making installation possible even in narrow ceilings. \* For 2.2 - 9.2kW type

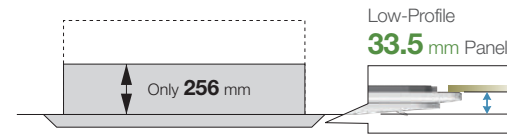

### Drain pump of up to 850 mm from the ceiling surface

Built in drain pump allows flexible install and design options with up to 850mm lift. Long horizontal piping is also possible.

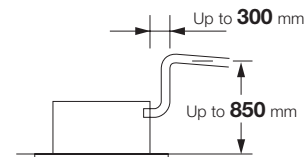

### Easy fine adjustment of the body suspension height!

The four corners of the ceiling panel have adopted removable corner pockets.

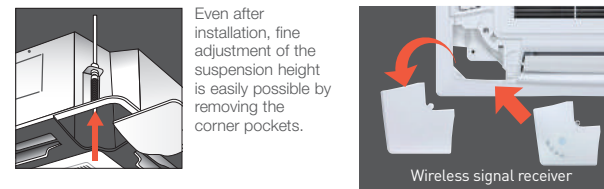

### Easy to clean suction grille & flap



It is easy to remove a washable flaps by hand.

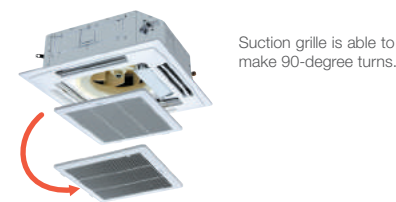

Suction grille is able to make 90-degree turns.

### Air flow directed to avoid ceiling marks

The condensation and dirt appearing near the discharge ports for conventional ceiling cassettes has been reduced.

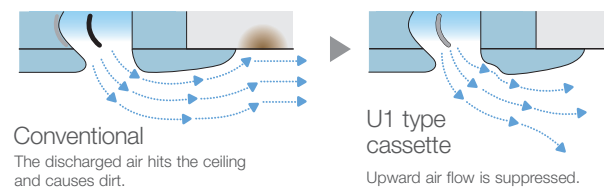

Conventional  
The discharged air hits the ceiling and causes dirt.

U1 type cassette  
Upward air flow is suppressed.

### Individual flap control

Flexible air flow direction control by individual flap control is possible. 4 Flaps can be controlled individually by setting on wired timer remote controller. This can allow flexible air-flow control to be matched to several demands in a room.

\* It needs pre-setting for this function at system test-run procedure.

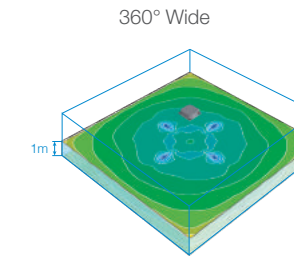
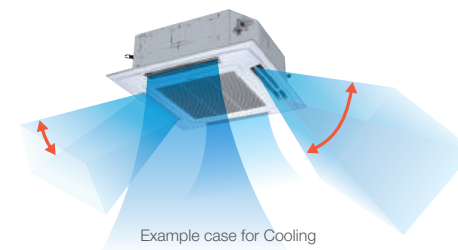

### Temperature distribution by thermograph (cooling operation)

Simulation conditions:  
140M 4-way ceiling-mounted cassette type in cooling mode  
/ Floor area of 225 m<sup>2</sup>  
/ Ceiling height of 3 m

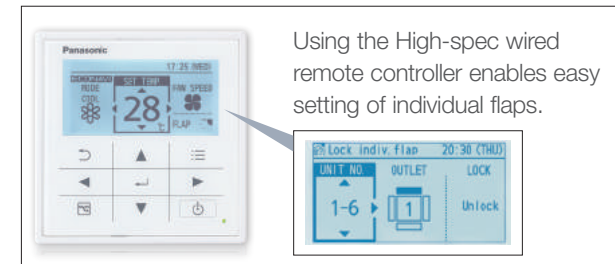

Using the High-spec wired remote controller enables easy setting of individual flaps.

### High-ceiling installation (Up to 5 m for 10.6 kW and higher capacity models)

The units can be installed in rooms with high ceilings, where they provide ample floor-level heating in the winter. (See ceiling height guidelines below.)

#### High Ceiling (Factory settings)

New model	2.7m	3.0m	3.6m
	Capacity	2.2-5.6kW	6.0-9.0kW

10.6-16.0kW	4.5m	4.7m	5m
	Capacity	4-way discharge high ceiling setting 2	3-way discharge with the optional air-blocking materials

### Ceiling height guidelines

Indoor unit	4-way discharge			3-way discharge (optional air-blocking materials)	2-way discharge (optional air-blocking materials) *2
	*1 settings	Factory setting 1	High ceiling setting 1		
2.2-5.6kW		2.7	3.2	3.5	3.8
6.0-9.0kW		3.0	3.3	3.6	3.8
10.6-16.0kW		3.6	3.9	4.5	4.7

\*1 When using the unit in a configuration other than the factory settings, it is necessary to make settings on site to increase airflow.  
\*2 Use air-blocking materials (CZ-CFU2) to completely block two discharge outlets for 2-way airflow.

**U1**<sub>TYPE</sub> 4-WAY Cassette

Model Name	S-22MU1E5A	S-28MU1E5A	S-36MU1E5A	S-45MU1E5A	S-56MU1E5A	S-60MU1E5A	S-73MU1E5A	S-90MU1E5A	S-106MU1E5A	S-140MU1E5A	S-160MU1E5A		
Power source	220/230/240 V, 1 phase - 50Hz/60Hz					220/230/240 V, 1 phase - 50Hz							
Cooling capacity	kW	2.2	2.8	3.6	4.5	5.6	6.0	7.3	9.0	10.6	14.0	16.0	
	BTU/h	7,500	9,600	12,300	15,400	19,100	20,500	24,900	30,700	36,200	47,800	54,600	
Heating capacity	kW	2.5	3.2	4.2	5.0	6.3	7.10	8.0	10.00	11.4	16.0	18.0	
	BTU/h	8,500	10,900	14,300	17,100	21,500	24,200	27,300	34,100	38,900	54,600	61,400	
Power input	Cooling kW	0.020/0.020/0.020	0.020/0.020/0.020	0.020/0.020/0.020	0.020/0.020/0.020	0.025/0.025/0.025	0.035/0.035/0.035	0.040/0.040/0.040	0.040/0.040/0.040	0.095/0.095/0.095	0.100/0.100/0.100	0.115/0.115/0.115	
	Heating kW	0.020/0.020/0.020	0.020/0.020/0.020	0.020/0.020/0.020	0.020/0.020/0.020	0.025/0.025/0.025	0.035/0.035/0.035	0.040/0.040/0.040	0.040/0.040/0.040	0.085/0.085/0.085	0.100/0.100/0.100	0.105/0.105/0.105	
Running current	Cooling A	0.19/0.19/0.18	0.19/0.19/0.18	0.19/0.19/0.18	0.19/0.19/0.19	0.22/0.22/0.21	0.32/0.31/0.30	0.36/0.33/0.32	0.39/0.36/0.35	0.73/0.71/0.71	0.77/0.76/0.73	0.90/0.89/0.87	
	Heating A	0.17/0.17/0.16	0.17/0.17/0.16	0.17/0.17/0.16	0.17/0.17/0.17	0.20/0.20/0.19	0.30/0.30/0.29	0.35/0.32/0.31	0.37/0.34/0.33	0.66/0.65/0.64	0.75/0.73/0.73	0.83/0.80/0.79	
Fan	Type	Turbo fan	Turbo fan	Turbo fan	Turbo fan	Turbo fan	Turbo fan	Turbo fan	Turbo fan	Turbo fan	Turbo fan		
	Air flow rate (H/M/L)	m <sup>3</sup> /h	840/720/660	840/720/660	840/720/660	900/780/720	960/810/720	1,260/1,020/840	1,320/1,020/840	1,380/1,140/900	1,980/1,620/1,260	2,100/1,680/1,320	2,160/1,740/1,380
	L/s	233/200/183	233/200/183	233/200/183	250/217/200	267/250/200	350/283/233	367/283/233	383/317/250	550/450/350	583/467/367	600/483/383	
Motor output	kW	0.06	0.06	0.06	0.06	0.06	0.06	0.06	0.09	0.09	0.09		
Sound power level (H/M/L)	dB	47/46/45	47/46/45	47/46/45	48/46/45	50/47/45	53/49/46	54/49/46	55/52/49	61/55/51	62/55/51	63/56/53	
Sound pressure level (H/M/L)	dB(A)	30/29/28	30/29/28	30/29/28	31/29/28	33/30/28	36/32/29	37/32/29	38/35/32	44/38/34	45/39/35	46/40/38	
Dimensions	H x W x D	mm 256+(33.5) x 840 (950) x 840 (950)					mm 319+(33.5) x 840 (950) x 840 (950)						
	Liquid	mm (inches)	Ø6.35 (Ø1/4)	Ø6.35 (Ø1/4)	Ø6.35 (Ø1/4)	Ø6.35 (Ø1/4)	Ø6.35 (Ø1/4)	Ø9.52 (Ø3/8)	Ø9.52 (Ø3/8)	Ø9.52 (Ø3/8)	Ø9.52 (Ø3/8)	Ø9.52 (Ø3/8)	Ø9.52 (Ø3/8)
Pipe connections	Gas	mm (inches)	Ø12.7 (Ø1/2)	Ø12.7 (Ø1/2)	Ø12.7 (Ø1/2)	Ø12.7 (Ø1/2)	Ø12.7 (Ø1/2)	Ø15.88 (Ø5/8)	Ø15.88 (Ø5/8)	Ø15.88 (Ø5/8)	Ø15.88 (Ø5/8)	Ø15.88 (Ø5/8)	
	Drain piping		VP-25	VP-25	VP-25	VP-25	VP-25	VP-25	VP-25	VP-25	VP-25	VP-25	
Net weight (Panel)	kg	23 (+4)	23 (+4)	23 (+4)	23 (+4)	23 (+4)	24 (+4)	24 (+4)	24 (+4)	27 (+4)	27 (+4)	27 (+4)	

GLOBAL REMARKS	Rated conditions:	
	Cooling	Heating
	Indoor air temperature	27°C DB / 19°C WB
Outdoor air temperature	35°C DB / 24°C WB	7°C DB / 6°C WB

Specifications are subject to change without notice.



**U1 TYPE 4-WAY CASSETTE Dimensions**

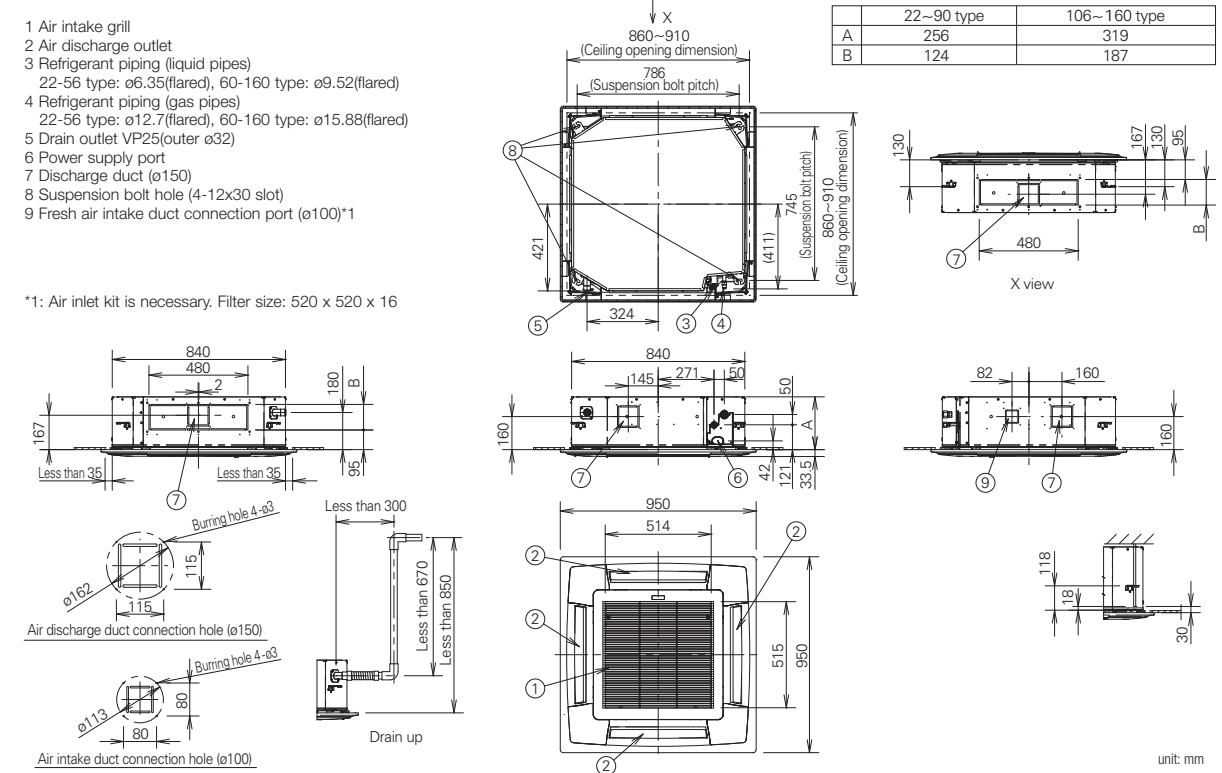

\* Adjust the suspension bolt length so that the gap from the lower ceiling surface becomes 30 mm or more (18 mm or more from the lower surface of the body) as shown in the figure. When the suspension bolt length is too long, it hits the ceiling panel and installation is not possible.

# Y2 TYPE 4-WAY Mini Cassette

## Mini semi concealed cassette



Designed to fit perfectly into a 60 x 60 cm ceiling grid without the need to alter the bar configuration, the Y2 is ideal for small commercial and retrofit applications. In addition, improvements to the Y2's efficiency make this model one of the most advanced units in the industry.

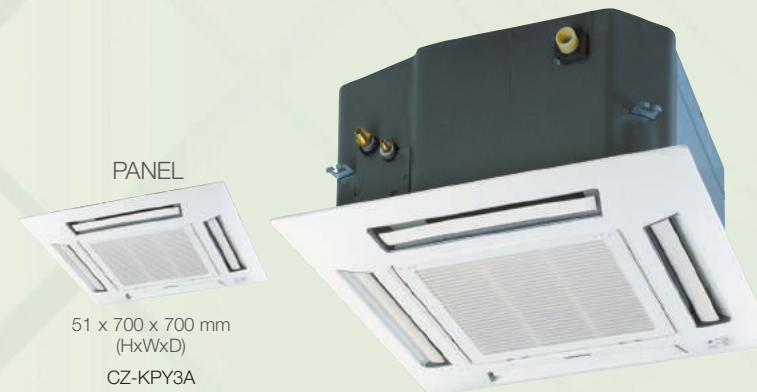

### Technical focus

- Mini cassette fits into a 60 x 60 cm ceiling grid
- Anti-mould and anti-bacteria washable filters
- Powerful drain pump gives 750 mm lift
- DC fan motor with variable speed and a new heat exchanger ensures efficient power consumption
- Fresh air knock out
- Multi directional air flow

### Compact design

The panel is a compact (70x70 cm) so it can be installed even in a small room where space is limited.

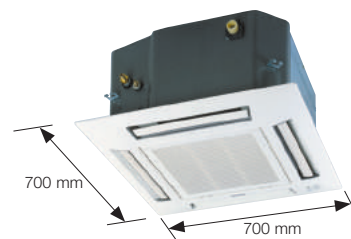

### Lighter and slimmer, easier installation

When only 260mm of indoor body height, it can easily fit in limited spaces and tight spots. (Required 288mm from bottom of panel to top of the unit)

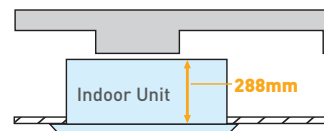

### A drain height of up to 750 mm from the ceiling surface

The internal pump allows the drain pipe to be elevated up to 750mm above the base of the unit.

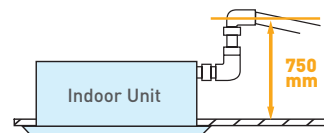

### Anti-Mould Long-Life Air Filter

Anti-mould and anti-bacteria washable filter ensures clean, healthy air.



Model Name		S-22MY2E5A	S-28MY2E5A	S-36MY2E5A	S-45MY2E5A	S-56MY2E5A
Power source		220/230/240 V, 1 phase - 50, 60 Hz				
Cooling capacity	kW	2.2	2.8	3.6	4.5	5.6
	BTU/h	7,500	9,600	12,300	15,400	19,100
Heating capacity	kW	2.5	3.2	4.2	5.0	6.3
	BTU/h	8,500	10,900	14,300	17,100	21,500
Power input	Cooling kW	0.035	0.035	0.040	0.040	0.045
	Heating kW	0.030	0.030	0.035	0.035	0.040
Running amperes	Cooling A	0.30	0.30	0.30	0.32	0.35
	Heating A	0.25	0.30	0.30	0.30	0.35
Fan motor	Type	Turbo fan				
	Airflow rate (H/M/L) m³/h	546	558	582	600	624
	L/s	152	155	162	167	173
	Output kW	0.04	0.04	0.04	0.04	0.04
Power sound level (H/M/L) dB	Cooling	50/48/46	50/48/46	51/49/47	53/51/48	55/52/49
	Heating	50/48/44	50/48/44	51/49/45	53/51/47	55/52/49
Sound pressure level (H/M/L) dB(A)	Cooling	35/33/31	35/33/31	36/34/32	38/36/33	40/37/34
	Heating	35/33/29	35/33/29	36/34/30	38/36/32	40/37/34
Dimensions* H x W x D mm		288 (+31) x 575 (700) x 575 (700)	288 (+31) x 575 (700) x 575 (700)	288 (+31) x 575 (700) x 575 (700)	288 (+31) x 575 (700) x 575 (700)	288 (+31) x 575 (700) x 575 (700)
	Liquid mm (inches)	Ø6.35 (Ø1/4)	Ø6.35 (Ø1/4)	Ø6.35 (Ø1/4)	Ø6.35 (Ø1/4)	Ø6.35 (Ø1/4)
Pipe connections	Gas mm (inches)	Ø12.7 (Ø1/2)	Ø12.7 (Ø1/2)	Ø12.7 (Ø1/2)	Ø12.7 (Ø1/2)	Ø12.7 (Ø1/2)
	Drain piping	VP-25	VP-25	VP-25	VP-25	VP-25
Net weight* kg		18 (+2.4)	18 (+2.4)	18 (+2.4)	18 (+2.4)	18 (+2.4)
GLOBAL REMARKS	Rated conditions:	Cooling	Heating			
	Indoor air temperature	27°C DB / 19°C WB	20°C DB			
	Outdoor air temperature	35°C DB / 24°C WB	7°C DB / 6°C WB			

\* The values in ( ) for external dimensions and Net weight are the values for the optional ceiling panel. Specifications are subject to change without notice.

### Y2 TYPE 4-WAY CASSETTE Dimensions

- 1 Air intake grill
- 2 Air outlet
- 3 Refrigerant piping (liquid pipe) ø6.35 (flared)
- 4 Refrigerant piping (gas pipe) ø12.7 (flared)
- 5 Drain tube connection port VP25 (outer ø32)
- 6 Power supply entry
- 7 Suspension bolt hole (4-11 x 26 slot)
- 8 Fresh air intake duct connection port (ø80)

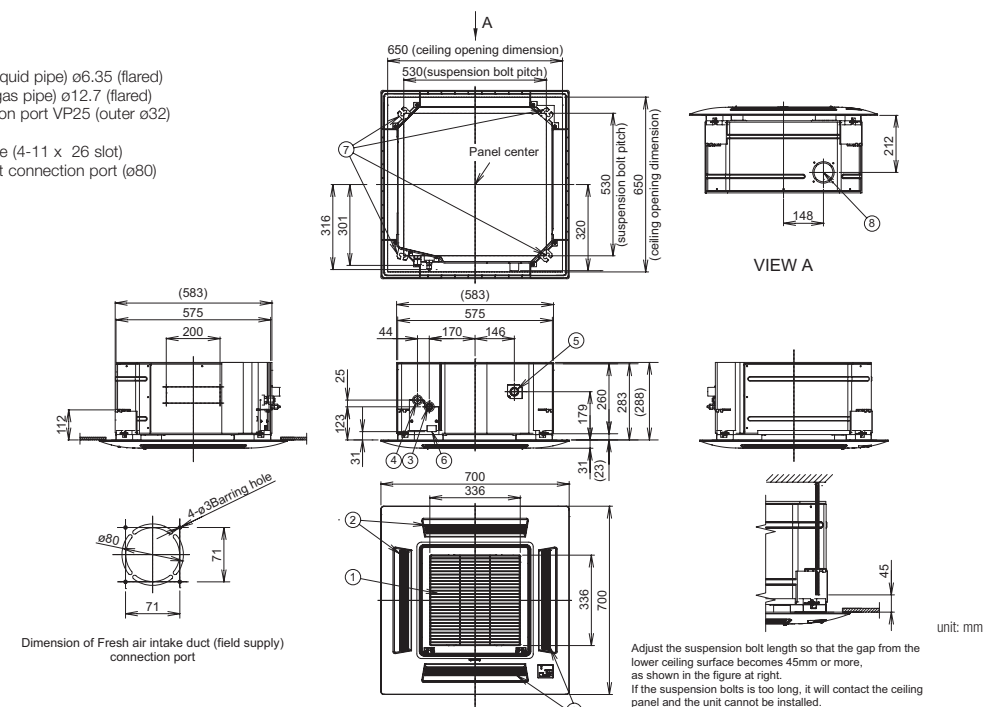



# L1 TYPE 2-WAY Cassette

The L1 is very thin, compact and light, allowing flexible install options. A redesigned fan has been used to achieve this size and weight reduction.

PANEL



CZ-02KPL2  
Big size panel (for S-73ML1E5)  
CZ-03KPL2



CZ-RTC5



Self-diagnosing Function



Automatic Fan Operation



Mild dry



Intelligent Auto Swing



Automatic Restart Function



Auto Swing (Auto Flap Control)



Built-in Drain Pump

## Technical focus

- Airflow and distribution is automatically altered depending on the operational mode of the unit
- Drain up is possible up to 500 mm via the built-in drain pump
- Simple maintenance

## Auto flap control

Airflow and distribution is automatically altered depending on the operational mode (cooling or heating) of the unit.

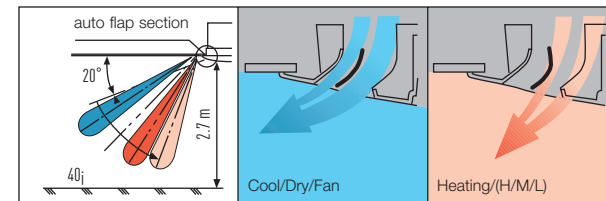

## Drain up is possible up to 500 mm via the built-in drain pump.

Maintenance of the drain pump is possible from both sides, from the left side (piping side) and from the inside of the unit.

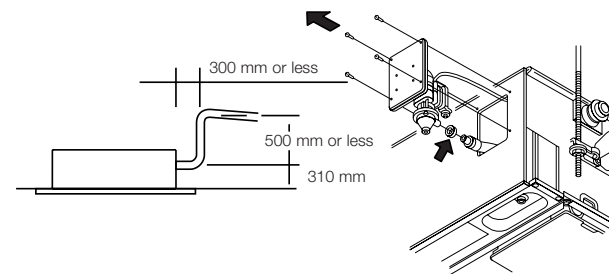

## Simple maintenance

The drain pan is equipped with site wiring and can be removed. The fan case has a split construction, and the fan motor can be removed easily when the lower case is removed.

Model Name		S-22ML1E5	S-28ML1E5	S-36ML1E5	S-45ML1E5	S-56ML1E5	S-73ML1E5	
Power source		220/230/240V, 1 phase - 50 / 60Hz						
Cooling capacity	kW	2.2	2.8	3.6	4.5	5.6	7.3	
	BTU/h	7,500	9,600	12,000	15,000	19,000	25,000	
Heating capacity	kW	2.5	3.2	4.2	5.0	6.3	8.0	
	BTU/h	8,500	11,000	14,000	17,000	21,000	27,000	
Power input	Cooling kW	0.086/0.090/0.095	0.086/0.092/0.097	0.088/0.093/0.099	0.091/0.097/0.103	0.091/0.097/0.103	0.135/0.145/0.154	
	Heating kW	0.055/0.058/0.062	0.055/0.060/0.064	0.057/0.061/0.066	0.060/0.065/0.070	0.060/0.065/0.070	0.100/0.109/0.117	
Running current	Cooling A	0.45/0.45/0.45	0.44/0.45/0.45	0.44/0.45/0.45	0.45/0.45/0.45	0.45/0.45/0.45	0.64/0.65/0.66	
	Heating A	0.29/0.29/0.30	0.28/0.29/0.30	0.28/0.29/0.30	0.29/0.29/0.30	0.29/0.29/0.30	0.46/0.48/0.49	
Fan	Type	Sirocco fan						
	Air flow rate (H/M/L)	m <sup>3</sup> /h	480/420/360	540/480/420	580/520/460	660/540/480	660/540/480	1,140/960/840
		L/s	133/117/100	150/133/117	161/144/128	183/150/133	183/150/133	317/267/233
	Motor output	kW						
			0.03	0.03	0.03	0.03	0.05	
Sound power level (H/M/L)	dB	40/38/35	44/40/37	45/42/39	46/44/40	46/44/40	49/46/44	
Sound pressure level (H/M/L)	dB(A)	30/27/24	33/29/26	34/31/28	35/33/29	35/33/29	38/35/33	
Dimensions * H x W x D	mm	350(8)x440(1,060)x600(880)	350(8)x440(1,060)x600(880)	350(8)x440(1,060)x600(880)	350(8)x440(1,060)x600(880)	350(8)x440(1,060)x600(880)	350(8)x1,140(1,360)x600(880)	
		Liquid	mm (inches)	Ø6.35 (Ø1/4)	Ø6.35 (Ø1/4)	Ø6.35 (Ø1/4)	Ø6.35 (Ø1/4)	Ø9.52 (Ø3/8)
Pipe connections	Gas	mm (inches)	Ø12.7 (Ø1/2)	Ø12.7 (Ø1/2)	Ø12.7 (Ø1/2)	Ø12.7 (Ø1/2)	Ø15.88 (Ø5/8)	
	Drain piping		VP-25	VP-25	VP-25	VP-25	VP-25	
Net weight *	kg	23 (+5.5)	23 (+5.5)	23 (+5.5)	23 (+5.5)	23 (+5.5)	30 (+9)	

GLOBAL REMARKS	Rated conditions:	
	Cooling	Heating
	Indoor air temperature 27°C DB / 19°C WB	20°C DB
	Outdoor air temperature 35°C DB / 24°C WB	7°C DB / 6°C WB

\* The values in ( ) for external dimensions and Net weight are the values for the optional ceiling panel. Specifications are subject to change without notice.

## L1 TYPE 2-WAY CASSETTE Dimensions

- 1 Air intake
- 2 Air outlet
- 3 Ceiling opening dimensions
- 4 Suspension fitting (notch: 12 mm)
- 5 Refrigerant piping (liquid pipes)
- 6 Refrigerant piping (gas pipes)
- 7 Drain connection VP25 (outer diameter ø 32)
- 8 Inlet for option cord between power supply and unit
- 9 Drain pan, drain pump inspection lid
- 10 Drain pump inspection lid
- 11 Round flange (field supply) mounting part (fresh air inlet ø 125)
- 12 Discharge duct (field supply) mounting part (installation possible only on the right side)
- 13 Wireless remote controller (option) signal receiver installation part

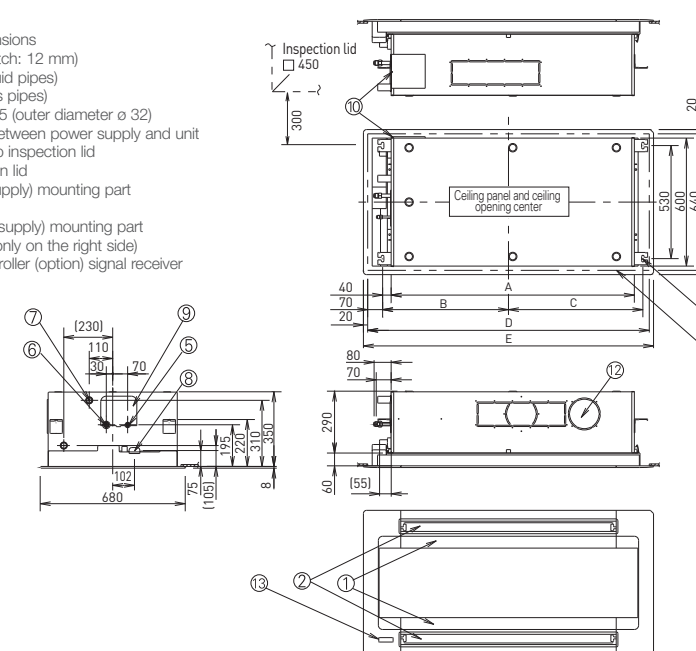

	22-56 type	73 type
A	840	1,140
B	440	590
C	480	630
D	1,020	1,320
E	1,060	1,360
③ Ceiling opening dimensions	1,020x640	1,320x640
⑤ Refrigerant piping (liquid pipes)	ø6.35	ø9.52
⑥ Refrigerant piping (gas pipes)	ø12.7	ø15.88
⑦ Duct connection port (only on the right side)	ø x 1 pc.	ø x 2 pc.

unit: mm

# D1 TYPE 1-WAY Cassette

## Semi concealed slim cassette



Designed for installation within the ceiling void, the D1 range of slimline 1 way cassettes feature a quiet yet powerful fan that can reach the floor up 4.2 m from ceiling height.



### Technical focus

- Ultra-Slim profile
- Suitable for standard and high ceilings
- Built-in drain pump provides 590 mm lift from ceiling
- Easy to install and maintain
- Hanging height can be easily adjusted
- Uses a DC fan motor to improve energy-efficiency

### Drain height

A built-in drain pump provides up to 590mm lift from ceiling height for flexible install options.

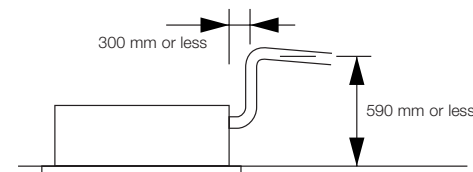

With 3 types of air-blow systems, the units can be used in various ways.



#### (1) One-direction "down-blow" system

Powerful one-direction "down-blow" system reaches the floor even from high ceilings (up to 4.2 m).



#### (2) Two-direction ceiling-mounted system

"Down-blow" and "front-blow" systems are combined in a ceiling-mounted unit to blow air over a wide area.



#### (3) One-direction ceiling-mounted system

This powerful ceiling-mounted "front-blow" system efficiently air-conditions the space in front of the unit. (Additional accessories required)

Model Name	S-28MD1E5	S-36MD1E5	S-45MD1E5	S-56MD1E5	S-73MD1E5	
Power source	220/230/240 V, 1 phase - 50 / 60 Hz					
Cooling capacity	kW	2.8	3.6	4.5	5.6	7.3
	BTU/h	9,600	12,000	15,000	19,000	25,000
Heating capacity	kW	3.2	4.2	5.0	6.3	8.0
	BTU/h	11,000	14,000	17,000	21,000	27,000
Power input	Cooling kW	0.050/0.051/0.052	0.050/0.051/0.052	0.050/0.051/0.052	0.058/0.060/0.061	0.086/0.087/0.089
	Heating kW	0.039/0.040/0.042	0.039/0.040/0.042	0.039/0.040/0.042	0.046/0.048/0.049	0.075/0.076/0.077
Running current	Cooling A	0.40/0.39/0.39	0.40/0.39/0.39	0.40/0.39/0.39	0.46/0.46/0.46	0.71/0.70/0.69
	Heating A	0.36/0.35/0.35	0.36/0.35/0.35	0.36/0.35/0.35	0.42/0.41/0.41	0.66/0.65/0.63
Fan	Type	Sirocco fan				
	Air flow rate (H/M/L) m <sup>3</sup> /h	720/600/540	720/600/540	720/660/600	780/690/600	1,080/900/780
	L/s	200/167/150	200/167/150	200/183/167	217/192/167	300/250/217
	Motor output kW	0.05				
Sound power level (H/M/L) dB	47/45/44	47/45/44	47/46/45	49/47/45	56/51/47	
Sound pressure level (H/M/L) dB(A)	36/34/33	36/34/33	36/35/34	38/36/34	45/40/36	
Dimensions * H x W x D mm	200+(20) x 1,000 (1,230) x 710 (800)	200+(20) x 1,000 (1,230) x 710 (800)	200+(20) x 1,000 (1,230) x 710 (800)	200+(20) x 1,000 (1,230) x 710 (800)	200+(20) x 1,000 (1,230) x 710 (800)	
	Liquid mm (inches)	Ø6.35 (Ø1/4)	Ø6.35 (Ø1/4)	Ø6.35 (Ø1/4)	Ø6.35 (Ø1/4)	Ø9.52 (Ø3/8)
Pipe connections	Gas mm (inches)	Ø12.7 (Ø1/2)	Ø12.7 (Ø1/2)	Ø12.7 (Ø1/2)	Ø12.7 (Ø1/2)	Ø15.88 (Ø5/8)
	Drain piping	VP-25	VP-25	VP-25	VP-25	VP-25
Net weight * kg	21 (+5.5)	21 (+5.5)	21 (+5.5)	21 (+5.5)	22 (+5.5)	
GLOBAL REMARKS	Rated conditions:	Cooling	Heating			
	Indoor air temperature	27°C DB / 19°C WB	20°C DB			
	Outdoor air temperature	35°C DB / 24°C WB	7°C DB / 6°C WB			

\* The values in ( ) for external dimensions and Net weight are the values for the optional ceiling panel. Specifications are subject to change without notice.

### D1 TYPE 1-WAY CASSETTE Dimensions

- 1 Air intake grille
- 2 Air outlet
- 3 Refrigerant piping (liquid pipes)  
Size 28 to 56: Ø6.35 (flared)  
Size 73: Ø9.52 (flared)
- 4 Refrigerant piping (gas pipes)  
Size 28 to 56: Ø12.7 (flared)  
Size 73: Ø15.88 (flared)
- 5 Drain connection VP25 (outer Ø32)
- 6 Power supply entry
- 7 Discharge duct connection port (for descending ceiling)
- 8 Wireless remote control receiver (option)
- 9 Suspension mounting (4-12 x 30 slot)
- 10 Fresh air intake (Ø100)

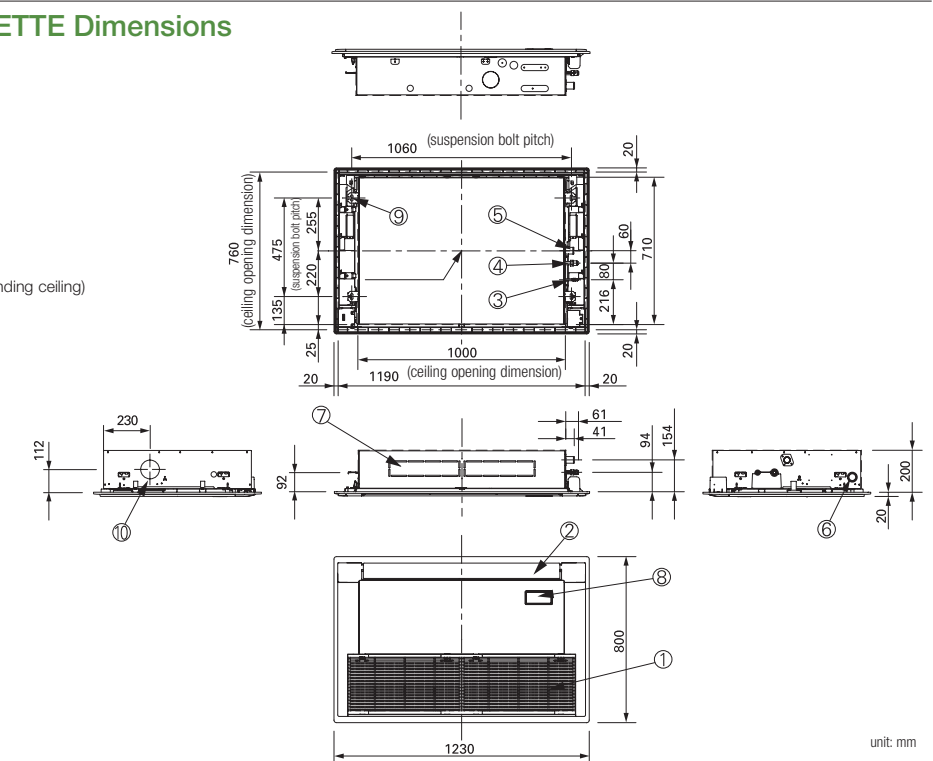

# T2 TYPE Ceiling Ceiling mounted



Providing outstanding energy-saving performance and comfortable, long-distance air flow distribution, it's recommended for stores and schools.



**ECONAVI**  
ECONAVI ready

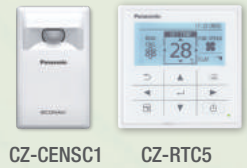

### Technical focus

- Lower sound levels
- Standardised height and depth for all models
- Long and wide air distribution
- Easy to install and maintain
- Fresh air knockout

### Compact Looking, Stylish, One-Motion Design

With its streamlined, one-motion form, the unit looks slim and compact when installed for a neat appearance in any room. When not operating, the louver closes to provide an elegant look while keeping the unit clean.



### Energy-Saving Technology Delivering Top-Class Efficiency

Optimization of the shape of the casing and fan assures bigger air flow and higher efficiency. Energy-saving performance is top class in the industry.

### Top Class Energy Saving

Large Diagonal Air Flow Fan

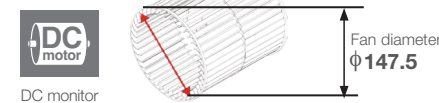

### Comfortable, Long-Distance Air Flow Distribution

The shape of the outlet has been optimized to provide long-distance air flow distribution. Even in deep spaces, air flow reaches every corner for exceptionally comfortable air conditioning.

High Ceiling Setting <small>*Setting by remote control</small>	Air flow distance		
	112	140	160
4.3m	12m	13m	13m

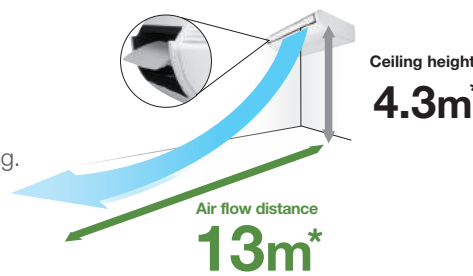

\*Results are based on specific testing conditions.

### Multiple Piping Directions For Flexible Installation

The 5-directional drain pipe and 3-directional refrigerant pipe make installation much easier. And the neat fit with walls and ceilings assures more installation flexibility.

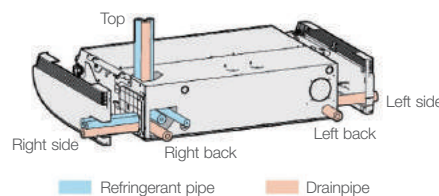

Model Name		S-36MT2E5A	S-45MT2E5A	S-56MT2E5A	S-73MT2E5A	S-106MT2E5A	S-140MT2E5A	
Power source		220 / 230 / 240 V, 1 phase - 50 / 60 Hz						
Cooling capacity	kW	3.6	4.5	5.6	7.3	10.6	14.0	
	BTU/h	12,300	15,400	19,100	24,900	36,200	47,800	
Heating capacity	kW	4.2	5.0	6.3	8.0	11.4	16.0	
	BTU/h	14,300	17,100	21,500	27,300	38,900	54,600	
Power input	Cooling kW	0.035/0.035/0.035	0.040/0.040/0.040	0.040/0.040/0.040	0.055/0.055/0.055	0.080/0.080/0.080	0.100/0.100/0.100	
	Heating kW	0.035/0.035/0.035	0.040/0.040/0.040	0.040/0.040/0.040	0.055/0.055/0.055	0.080/0.080/0.080	0.100/0.100/0.100	
Running current	Cooling A	0.37/0.36/0.35	0.39/0.38/0.37	0.39/0.38/0.37	0.45/0.44/0.43	0.69/0.67/0.65	0.82/0.79/0.77	
	Heating A	0.37/0.36/0.35	0.39/0.38/0.37	0.39/0.38/0.37	0.45/0.44/0.43	0.69/0.67/0.65	0.82/0.79/0.77	
Fan	Type	Sirocco fan						
	Air flow rate (H/M/L)	m³/h	840/720/630	900/750/630	900/750/630	1,260/1,080/930	1,800/1,500/1,380	1,920/1,680/1,440
		L/s	233/200/175	250/208/175	250/208/175	350/300/258	500/417/383	533/467/400
	Motor output	kW	0.043	0.043	0.043	0.074	0.111	0.111
Sound power level (H/M/L)		dB	54/50/48	55/51/48	55/51/48	57/53/51	60/55/54	62/58/55
	Sound pressure level (H/M/L)	dB(A)	36/32/30	37/33/30	37/33/30	39/35/33	42/37/36	44/40/37
Dimensions	H x W x D	mm	235 x 960 x 690	235 x 960 x 690	235 x 960 x 690	235 x 1,275 x 690	235 x 1,590 x 690	235 x 1,590 x 690
	Liquid	mm (inches)	Ø6.35 (Ø1/4)	Ø6.35 (Ø1/4)	Ø6.35 (Ø1/4)	Ø9.52 (Ø3/8)	Ø9.52 (Ø3/8)	Ø9.52 (Ø3/8)
Pipe connections	Gas	mm (inches)	Ø12.7 (Ø1/2)	Ø12.7 (Ø1/2)	Ø12.7 (Ø1/2)	Ø15.88 (Ø5/8)	Ø15.88 (Ø5/8)	Ø15.88 (Ø5/8)
	Drain piping		VP-20	VP-20	VP-20	VP-20	VP-20	VP-20
Net weight	kg	27	27	27	33	40	40	

GLOBAL REMARKS	Rated conditions:	
	Cooling	Heating
	Indoor air temperature 27°C DB / 19°C WB	20°C DB
Outdoor air temperature	35°C DB / 24°C WB	7°C DB / 6°C WB

Specifications are subject to change without notice.

### T2 TYPE CEILING Dimensions

S-36MT2E5A // S-45MT2E5A // S-56MT2E5A

1   Drain port VP20	Inside diameter ø26mm, drain hose supplied
2   Left drain position	
3   Refrigerant liquid tubing	Ø6.35mm for 36-56type, Ø9.52mm for 73-140type
4   Refrigerant gas tubing	Ø12.7mm for 36-56type, Ø15.88mm for 73-140type
5   Left side drain hose outlet part (cutout)	
6   Tubing hole on wall surface	Ø100mm
7   Upper side tubing part	
8   Right side drain hose outlet part (cutout)	
9   Wireless remote controller receiver installation location	

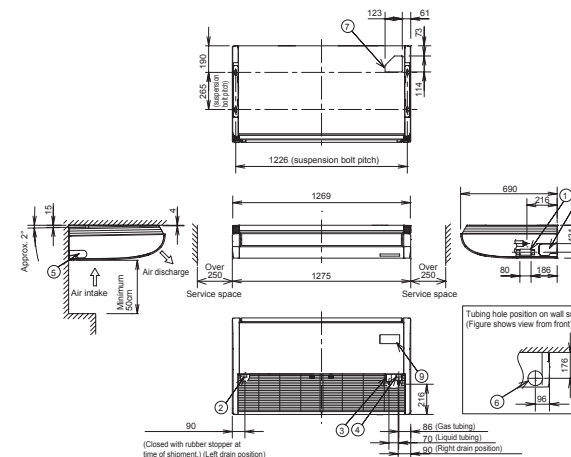

unit: mm

S-73MT2E5A // S-106MT2E5A // S-140MT2E5A

	A	B	C	D	E
106-140 type	1,590	235	690	1,584	1,541
73 type	1,275	235	690	1,269	1,226

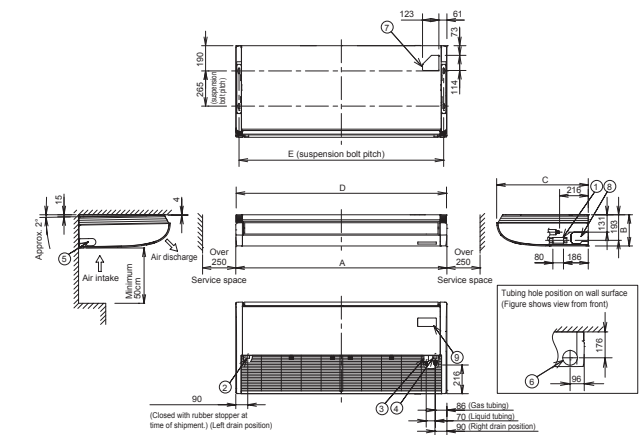

unit: mm

# P1 TYPE Floor Standing

The compact floor standing P1 units are the ideal solution for providing perimeter air conditioning. A standard wired controller can be incorporated into the body of the unit.



-   
 Self-diagnosing Function
-   
 Automatic Fan Operation
-   
 Automatic Restart Function

## Technical focus

- Pipes can be connected to either side of the unit from the bottom or rear
- Easy to install
- Front panel opens fully for easy maintenance
- Removable air discharge grille gives flexible air flow

## Effective perimeter air conditioning

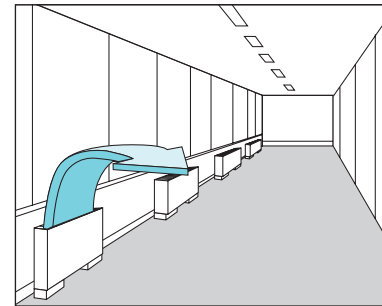

A standard wired remote control can be installed in the body

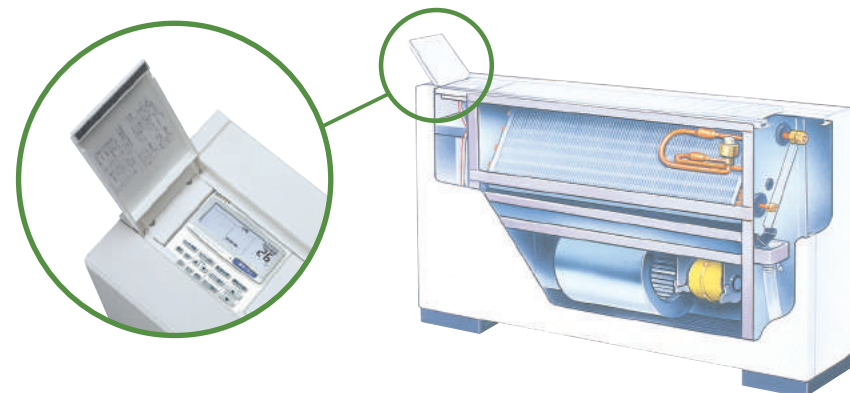

Model Name	S-22MP1E5	S-28MP1E5	S-36MP1E5	S-45MP1E5	S-56MP1E5	S-71MP1E5	
Power source	220/230/240 V, 1 phase - 50 / 60 Hz						
Cooling capacity	kW	2.2	2.8	3.6	4.5	7.1	
	BTU/h	7,500	9,600	12,000	15,000	24,000	
Heating capacity	kW	2.5	3.2	4.2	5.0	8.0	
	BTU/h	8,500	11,000	14,000	17,000	27,000	
Power input	Cooling kW	0.051/0.056/0.061	0.051/0.056/0.061	0.079/0.085/0.091	0.116/0.126/0.136	0.150/0.160/0.170	
	Heating kW	0.036/0.040/0.045	0.036/0.040/0.045	0.064/0.070/0.076	0.079/0.091/0.101	0.110/0.120/0.130	
Running current	Cooling A	0.24/0.25/0.26	0.24/0.25/0.26	0.37/0.38/0.39	0.54/0.56/0.58	0.70/0.72/0.73	
	Heating A	0.17/0.18/0.19	0.17/0.18/0.19	0.30/0.31/0.32	0.37/0.41/0.43	0.52/0.54/0.56	
Fan	Type	Sirocco fan	Sirocco fan	Sirocco fan	Sirocco fan	Sirocco fan	
	Air flow rate (H/M/L)	m³/h	420/360/300	420/360/300	540/420/360	720/540/480	900/780/660
		L/s	117/100/83	117/100/83	150/117/100	200/150/133	250/217/183
	Motor output kW	0.01	0.01	0.02	0.02	0.03	0.06
Sound power level (H/M/L)	dB	44/41/39	44/41/39	50/46/40	49/46/42	50/47/42	52/49/46
Sound pressure level (H/M/L)	dB(A)	33/30/28	33/30/28	39/35/29	38/35/31	39/36/31	41/38/35
Dimensions H x W x D	mm	615 x 1,065 x 230	615 x 1,065 x 230	615 x 1,065 x 230	615 x 1,380 x 230	615 x 1,380 x 230	615 x 1,380 x 230
	Liquid mm (inches)	Ø6.35 (Ø1/4)	Ø6.35 (Ø1/4)	Ø6.35 (Ø1/4)	Ø6.35 (Ø1/4)	Ø6.35 (Ø1/4)	Ø9.52 (Ø3/8)
	Gas mm (inches)	Ø12.7 (Ø1/2)	Ø12.7 (Ø1/2)	Ø12.7 (Ø1/2)	Ø12.7 (Ø1/2)	Ø12.7 (Ø1/2)	Ø15.88 (Ø5/8)
Pipe connections	Drain piping	VP-20	VP-20	VP-20	VP-20	VP-20	
	Net weight kg	29	29	29	39	39	39

GLOBAL REMARKS	Rated conditions:		Cooling	Heating
	Indoor air temperature	27°C DB / 19°C WB	27°C DB	20°C DB
	Outdoor air temperature	35°C DB / 24°C WB	35°C DB	7°C DB / 6°C WB

Specifications are subject to change without notice.

## P1 TYPE FLOOR STANDING Dimensions

- 1 4 x Ø12 holes (for floor fixing)
- 2 Power supply outlet
- 3 Air filter
- 4 Refrigerant piping (liquid pipes)
- 5 Refrigerant piping (gas pipes)
- 6 Level adjustment bolt
- 7 Drain outlet VP20 (with vinyl hose)
- 8 Refrigerant piping connection port (bottom or rear)
- 9 Operation switch (remote controller RCS-SH80AG) mounting part
- 10 Electric equipment box
- 11 Accessory copper pipe for gas pipe connection

Indoor unit	A	B	C	Liquid pipes	Gas pipes
22 to 36 type	1,065	665	632	Ø6.35	Ø12.7
45 type					
56 type	1,380	980	947	Ø9.52	Ø15.88
71 type					

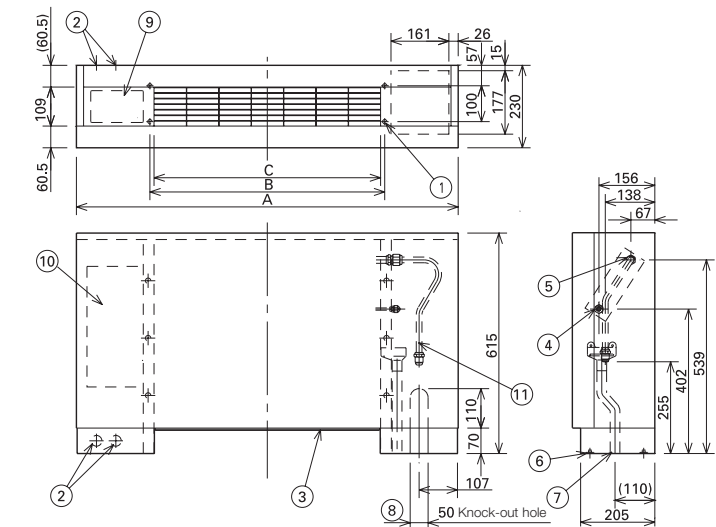

unit: mm

# R1 TYPE Concealed Floor Standing

At just 229 mm deep, the R1 unit can be easily concealed in perimeter areas to provide powerful and effective air conditioning.

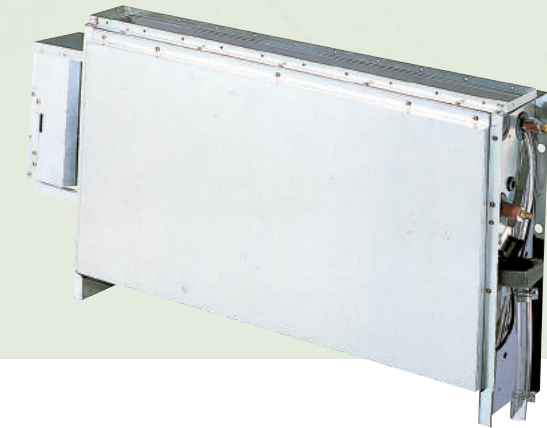

## Technical focus

- Chassis unit for discrete customisable installation
- Complete with removable filters
- Pipes can be connected to the unit either from the bottom or rear
- Easy to install

## Perimeter air conditioning with high interior quality

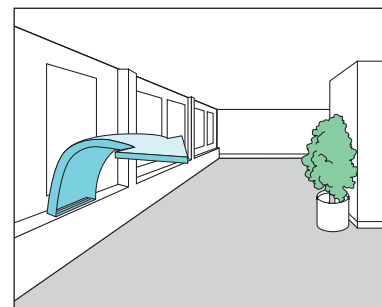

Model Name	S-22MR1E5	S-28MR1E5	S-36MR1E5	S-45MR1E5	S-56MR1E5	S-71MR1E5		
Power source	220/230/240 V, 1 phase - 50, 60 Hz							
Cooling capacity	kW	2.2	2.8	3.6	4.5	7.1		
	BTU/h	7,500	9,600	12,000	15,000	24,000		
Heating capacity	kW	2.5	3.2	4.2	5.0	8.0		
	BTU/h	8,500	11,000	14,000	17,000	27,000		
Power input	Cooling kW	0.051/0.056/0.061	0.051/0.056/0.061	0.079/0.085/0.091	0.116/0.126/0.136	0.116/0.126/0.136	0.150/0.160/0.170	
	Heating kW	0.036/0.040/0.045	0.036/0.040/0.045	0.064/0.070/0.076	0.079/0.091/0.101	0.079/0.091/0.101	0.110/0.120/0.130	
Running current	Cooling A	0.24/0.25/0.26	0.24/0.25/0.26	0.37/0.38/0.39	0.54/0.56/0.58	0.54/0.56/0.58	0.70/0.72/0.73	
	Heating A	0.17/0.18/0.19	0.17/0.18/0.19	0.30/0.31/0.32	0.37/0.41/0.43	0.37/0.41/0.43	0.52/0.54/0.56	
Fan	Type	Sirocco fan						
	Air flow rate (H/M/L)	m³/h	420/360/300	420/360/300	540/420/360	720/540/480	900/780/660	1,020/840/720
	L/s		117/100/183	117/100/183	150/117/100	200/150/133	250/217/183	283/233/200
	Motor output kW		0.01	0.01	0.02	0.02	0.03	0.06
Sound power level (H/M/L)	dB	44/41/39	44/41/39	50/46/40	49/46/42	49/46/42	52/49/46	
Sound pressure level (H/M/L)	dB(A)	33/30/28	33/30/28	39/35/29	38/35/31	39/36/31	41/38/35	
Dimensions	H x W x D	mm	616 x 904 x 229	616 x 904 x 229	616 x 904 x 229	616 x 1,219 x 229	616 x 1,219 x 229	616 x 1,219 x 229
	Liquid	mm (inches)	Ø6.35 (Ø1/4)	Ø6.35 (Ø1/4)	Ø6.35 (Ø1/4)	Ø6.35 (Ø1/4)	Ø6.35 (Ø1/4)	Ø9.52 (Ø3/8)
	Gas 410 A	mm (inches)	Ø12.7 (Ø1/2)	Ø12.7 (Ø1/2)	Ø12.7 (Ø1/2)	Ø12.7 (Ø1/2)	Ø12.7 (Ø1/2)	Ø15.88 (Ø5/8)
	Drain piping		VP-20	VP-20	VP-20	VP-20	VP-20	VP-20
Net weight	kg	21	21	21	28	28	28	

GLOBAL REMARKS	Rated conditions:		Specifications are subject to change without notice.
	Indoor air temperature	Cooling 27°C DB / 19°C WB	Heating 20°C DB
	Outdoor air temperature	35°C DB / 24°C WB	7°C DB / 6°C WB

## R1 TYPE CONCEALED FLOOR STANDING Dimensions

- 1 4 x Ø12 holes (for floor fixing)
- 2 Electric equipment box
- 3 Power supply outlet
- 4 Air filter
- 5 Discharge duct connection flange
- 6 Refrigerant connection outlet (liquid pipes)
- 7 Refrigerant connection outlet (gas pipes)
- 8 Drain filter
- 9 Drain pan
- 10 Level adjustment bolt
- 11 Drain outlet VP20 (with vinyl hose)

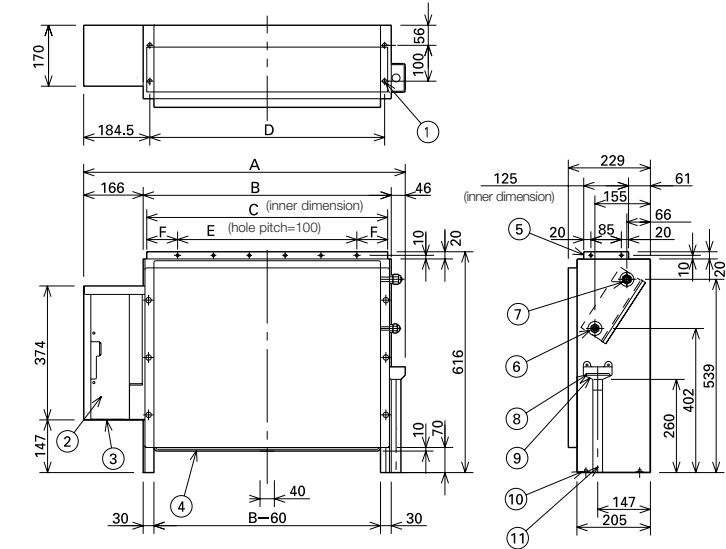

Indoor unit	A	B	C	D	E	F	Liquid pipes	Gas pipes
22 to 36 type	904	692	672	665	500	86		
45 type							Ø6.35	Ø12.7
56 type	1,219	1,007	1,002	980	900	51		
71 type							Ø9.52	Ø15.88

unit: mm

## Remark For High Static Ducted Series



E2 type  
High Static Ducted



E2 type  
Energy Saving  
High-Fresh Air Ducted



E1 type  
High Static Ducted

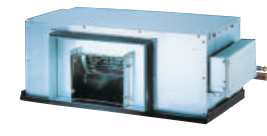

H1 type  
High-Fresh Air Ducted



Model	Operation	Rap valve kit CZ-P160RVK2	3-way control PCB CZ-CAPE2	3-way valve kit CZ-P160HR3	3-way valve kit multiple connection port type 4 port CZ-P4160HR3 (160 type) X 4pcs	Distribution Joint kit <2pipes> CZ-P160BK2 for 22.4kW unit	Distribution Joint kit <3pipes> CZ-P224BH2 for 22.4kW unit CZ-P680BH2 for 28.0kW unit
E2 Type High Static Ducted	Cooling Only	-	-	-	-	-	-
	Cool or Heat	-	-	-	-	-	-
	Heat Recovery	-	2pcs	2pcs	use 2ports	1pc	1pc
E2 Type Energy Saving High-Fresh Air Ducted	Cooling Only	-	-	-	-	-	-
	Cool or Heat	2pcs	2pcs	-	-	2pcs	-
	Heat Recovery	-	2pcs	2pcs	use 2ports	1pc	1pc
E1 Type High Static Ducted (Only for S-224,S-280)	Cooling Only	-	-	-	-	-	-
	Cool or Heat	2pcs	-	-	-	2pcs	-
	Heat Recovery	-	-	2pcs	use 2ports	1pc	1pc
H1 Type High-Fresh Air Ducted	Cooling Only	-	-	-	-	-	-
	Cool or Heat	2pcs	-	-	-	2pcs	-
	Heat Recovery	-	-	2pcs	use 2ports	1pc	1pc



# FSV Controllers

A wide variety of control options to meet the requirements of different applications.

**ECONAVI**  
**ECONAVI Sensor**  
 CZ-CENSC1



Utilises ECONAVI Sensor and Control Program technologies to detect where energy is normally wasted and self-adjusts cooling power to reduce energy waste.

- Activity detection
- Absence detection

OPERATION SYSTEM	INDIVIDUAL CONTROL SYSTEMS				TIMER OPERATION	CENTRALISED CONTROL SYSTEMS			BMS System PC Base	Connection with 3rd Party Controller
Requirements	High-spec operation	Normal operation	Operation from anywhere in the room	Quick and easy operation	Daily and weekly program	Operation with various functions from a central location	Only ON/OFF operation from a central location	Simplified load distribution ratio (LDR) for each tenant Touch screen panel		
External appearance									<b>P-AIMS Software</b> Up to 1024 units 	<b>Seri-Para I/O unit for outdoor unit</b> 
Type, model name	CZ-RTC5	CZ-RTC4	CZ-RWSU2N CZ-RWSD2 CZ-RWST3N CZ-RWSC3 CZ-RWSK2	CZ-RE2C2	CZ-ESWC2	CZ-64ESMC3	CZ-ANC2	CZ-256ESMC2 (CZ-CFUNC2)	<b>Optional software</b> 	<b>Interface Adaptor</b> 
Built-in thermostat	●	●	●	●	—	—	—	—		
ECONAVI ON/OFF control	●	●	—	—	—	●	—	—		
Number of indoor units which can be controlled	1 group, 8 units	1 group, 8 units	1 group, 8 units	1 group, 8 units	64 groups, max. 64 units	64 groups, max. 64 units	16 groups, max. 64 units	64 units x 4 links, max. 256 units		<b>Seri-Para I/O unit for each indoor unit</b> 
Use limitations	· Up to 2 controllers can be connected per group (When using ECONAVI sensor, only one remote controller is possible to connect at indoor unit)	· Up to 2 controllers can be connected per group (When using ECONAVI sensor, only one remote controller is possible to connect at indoor unit)	· Up to 2 controllers can be connected per group.	· Up to 2 controllers can be connected per group.	· Required power supply from the system controller · When there is no system controller, connection is possible to the T10 terminal of an indoor unit.	· Up to 10 controllers, can be connected to one system. · Main unit/sub unit (1 main unit + 1 sub unit) connection is possible. · Use without remote controller is possible.	· Up to 8 controllers (4 main units + 4 sub units) can be connected to one system. · Use without remote controller is impossible.	· A communication adaptor (CZ-CFUNC2) must be installed for three or more links.	<b>Communication Adaptor</b> 	
Function ON/OFF	●	●	●	●	—	●	●	●		
Mode setting	●	●	●	●	—	●	—	●		
Fan speed setting	●	●	●	●	—	●	—	●		
Temperature setting	●	●	●	●	—	●	—	●		
Air flow direction	●	●	●	●	—	●	—	●		
Permit/Prohibit switching	●	—	—	—	—	●	●	●		
Weekly program	●	●	—	—	●	●	—	●		

All specifications are subject to change without notice.

**Web Interface Systems**

CZ-CWIBC2  
 \*PC required (field supply)

**LonWorks Interface**

CZ-CLNC2

## Individual Control Systems

Control contents	Part name, model No.	Quantity
<b>Standard Control</b> <ul style="list-style-type: none"> <li>Control of the various operations of the indoor unit by wired or wireless remote controller.</li> <li>Cooling or heating mode of the outdoor unit is decided by the first priority of the remote controller.</li> <li>Switching between remote controller sensor and body sensor is possible.</li> </ul>	Timer remote controller CZ-RTC4 / CZ-RTC5 Simplified remote controller CZ-RE2C2 Wireless remote controller CZ-RWSU2N / CZ-RWSL2N / CZ-RWSC3 / CZ-RWSK2 / CZ-RWST3N / CZ-RWSD2	1 unit each
<b>(1) Group control</b> <ul style="list-style-type: none"> <li>Batch remote control on all indoor units.</li> <li>Operation of all indoor units in the same mode.</li> <li>Up to 8 units can be connected.</li> <li>The sensor is the body sensor, and thermostat ON/OFF setting in regard to the temperature set by the remote controller is possible for each indoor unit.</li> </ul>	Timer remote controller CZ-RTC4 / CZ-RTC5 Simplified remote controller CZ-RE2C2 Wireless remote controller CZ-RWSU2N / CZ-RWSL2N / CZ-RWSC3 / CZ-RWSK2 / CZ-RWST3N / CZ-RWSD2	1 unit
<b>(2) Main/sub remote control</b> <ul style="list-style-type: none"> <li>Max 2 remote controllers per indoor unit. (Main remote controller can be connected)</li> <li>The button pressed last has priority.</li> <li>Timer setting is possible even with the sub remote controller. (When using ECONAVI sensor, only one remote controller is possible to connect at indoor unit)</li> </ul>	Main or sub Timer remote controller CZ-RTC4 / CZ-RTC5 Simplified remote controller CZ-RE2C2 Wireless remote controller CZ-RWSU2N / CZ-RWSL2N / CZ-RWSC3 / CZ-RWSK2 / CZ-RWST3N / CZ-RWSD2	As required

### SYSTEM EXAMPLE FSV

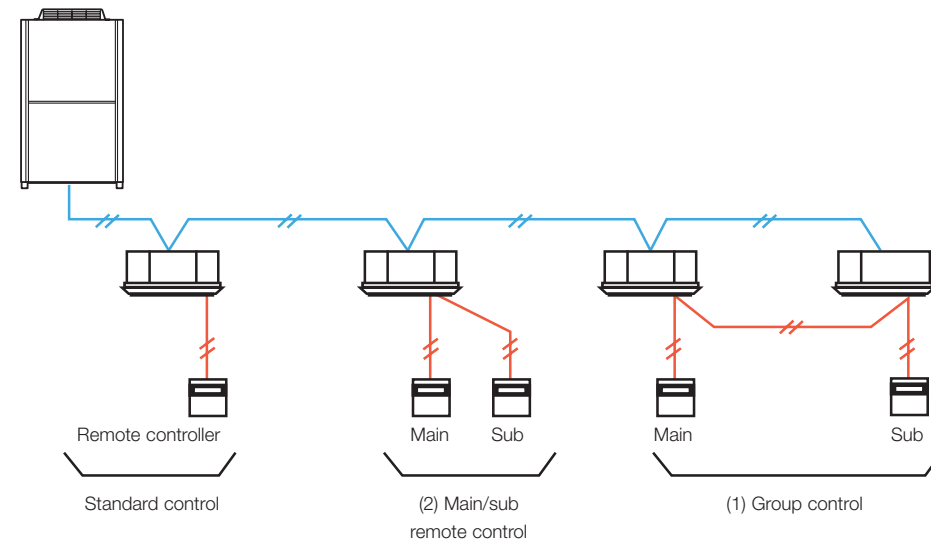

### High-spec wired remote controller (CZ-RTC5)

**NEW**



Dimensions  
H 120 x W 120 x  
D 16 mm

#### Basic Operation

- Individual Louver Control (Lock individual flap only for 4-way cassette U1 type)
- ON/ OFF timer
- Weekly Timer
- Filter information\*
- Outing function
- Quiet operation mode\*
- Energy saving
- Initial settings
- Ventilation

#### Maintenance Function

- Outdoor unit error data
- Service Contact address
- RC setting mode
- Test Run
- Sensor Information
- Service check
- Simple/ Detailed Settings
- Auto address

\* Depending on the model, some menus cannot be used.

#### Energy Saving

- ECONAVI on/ off\*
- Temperature Auto Return
- Temperature Setting Range
- Auto Shutoff
- Schedule peak cut
- Repeat off timer

### Timer remote controller (CZ-RTC4)

**NEW**

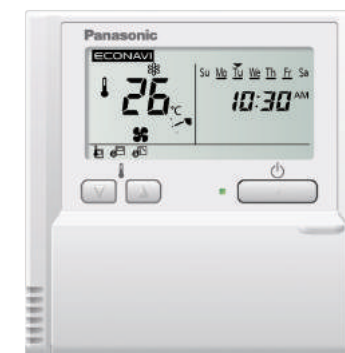

Dimensions  
H 120 x W 120 x  
D 20 mm

#### Weekly Programme Function

- A maximum of 6 settings/day and 42 settings/week can be programmed.

#### Outing Function

- This function can prevent the room temperature from dropping or rising when the occupants are out for a long time.

#### Sleeping Function

- This function controls the room temperature for comfortable sleeping.

#### Max. 8 indoor units can be controlled from one remote controller

#### Remote control by main remote controller and sub controller is possible

Max. 2 remote controllers (main remote controller and sub controller) can be installed for one indoor unit.

\* Depending on the model, some menus cannot be used.

#### Basic remote controller ON/OFF

- Operation mode changeover (Cooling, Heating, Dry, Auto, Fan).
- Temperature setting (Cooling/Dry: 18-30 deg Heating: 16-30 deg).
- Fan speed setting H/ M/ L and Auto.
- Air flow direction adjustment.
- ECONAVI on/ off\*

#### Time Function 24 hours real time clock

- Day of the week indicator.



Wireless remote controller

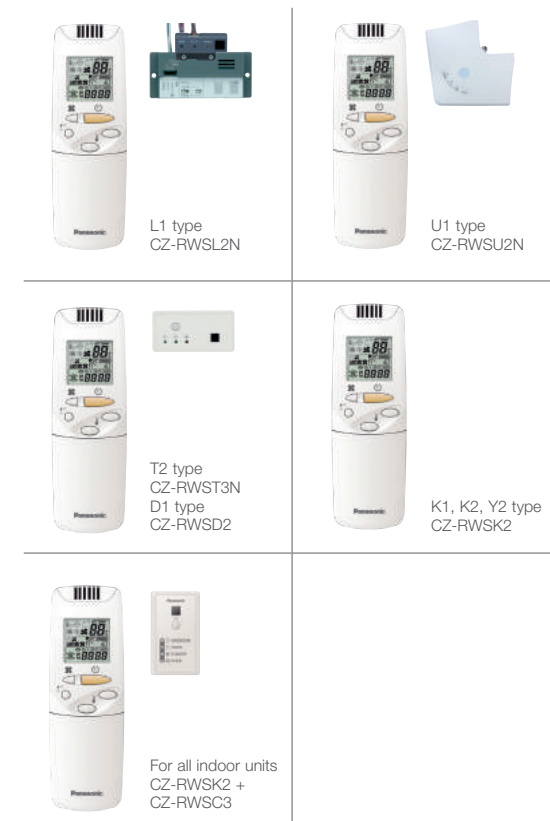

Remote control by main remote controller and sub controller is possible

- Max. 2 remote controllers (main remote controller and sub controller) can be installed for one indoor unit.

When CZ-RWSC3 is used, wireless control becomes possible for all indoor units

- When a separate receiver is set up in a different room, control from that room also becomes possible.
- Automatic operation by means of the emergency operation button is possible even when the remote controller has been lost or the batteries have been exhausted.

In addition, there are other functions such as temperature setting, operation switching, airflow direction/fan speed setting, etc

Ventilation independent operation is possible

When commercial ventilation fans or heat-exchange ventilation fans have been installed, they can be operated with this remote control (interlocked operation with the indoor unit or independent ventilation ON/OFF).

Simplified remote controller (CZ-RE2C2)



Dimensions  
H 120 x W 70 x D 17 mm

A remote controller with simple functions and basic operation

- Suitable for open rooms or hotels where detailed functions are not required.
- ON/OFF, operation mode switching, temperature setting, airflow velocity switching, airflow direction setting, alarm display, and remote controller self-diagnosis can be performed.
- Batch group control for up to 8 indoor units.
- Remote control by main remote controller and sub controller is possible with a simplified remote controller or a wired remote controller (up to two units).
- Built-in temperature sensor

Timer Operation

Schedule timer (CZ-ESWC2)



Dimensions  
H 120 x W 120 x D 16 mm

• A function for pausing the timer in case of national holidays has been added, and timer operation also can be stopped for a long time

- By setting holidays or operation stop within one week, the timer can be paused just for that week.
- All timer settings can be stopped with the timer "ON/OFF effective" button. (Return to timer operation is made by pressing the button again.)

Up to 64 groups (max 64 indoor units) can be controlled divided into 8 timer groups

• Six program operations (Operation/Stop/Local permission/ Local prohibition) per day can be set in a program for one week

- Only operation or stop, remote controller local permission or remote controller local prohibition, and their respective combinations are possible. (Operation + local permission, stop + local prohibition, only local permission, etc.)
- Local prohibition and the combination of the three items of temperature setting, mode change, and operation/stop can be set at the time of installation.

The power supply for the schedule timer is taken from one of the following.

1. Control circuit board (T10) of a nearby indoor unit (power supply wiring length: within 200m from the indoor unit).
2. System controller (power supply wiring length: within 100 m from the indoor unit).

When the power supply for the schedule timer is taken from the control circuit board of the indoor unit, that indoor unit cannot be used with other control devices using the T10 terminal.

As operation mode and temperature settings are not possible with the schedule timer, it must be used together with a remote controller, a system controller, an intelligent controller, etc. Also, as it does not have an address setting function, the control function of a system controller etc. must be used for address setting.

Connection example 1 (POWER SUPPLY FROM THE INDOOR UNIT)

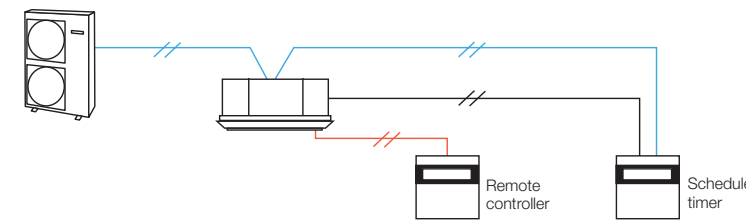

Connection example 2 (POWER SUPPLY FROM THE SYSTEM CONTROLLER AND ON/OFF CONTROLLER)

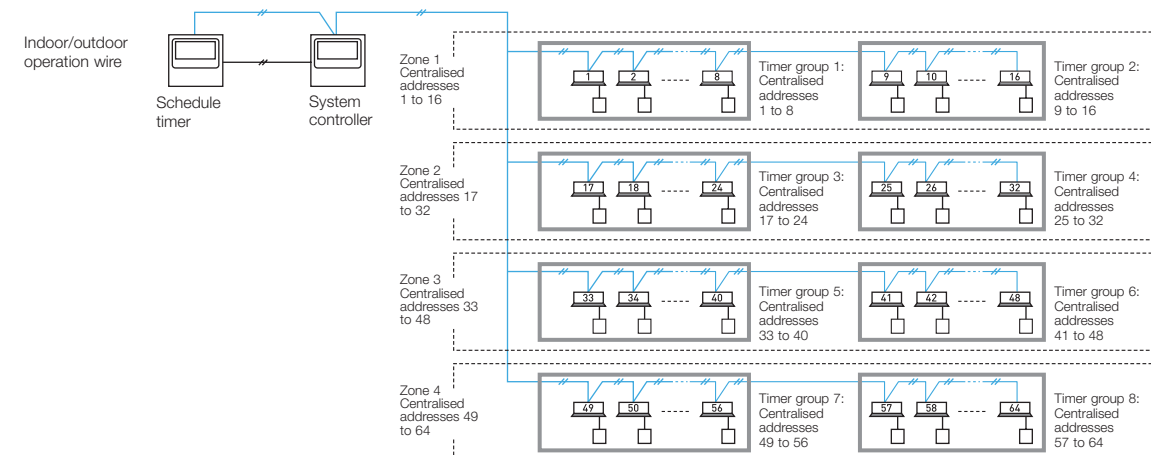

# Centralised Control Systems

## System controller (CZ-64ESMC3)

**NEW**

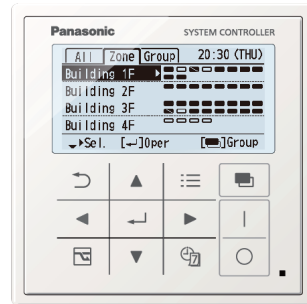

Dimensions  
H 120 x W 120 x D 16 + 52  
(embedding dimension mm)

Power supply: AC 100 to 240 V  
I/O part:  
Remote input part (effective voltage:DC24V) All operation,All stop,Demand 1,Demand 2  
Remote output part (non voltage contact) Operation, Alarm (external power supply within DC 30V, max 0.5A)  
Total wiring length : 1 km

Individual control is possible for max 64 groups, 64 indoor units.

- Control of 64 indoor units divided into 4 zones. (One zone can have up to 16 groups, and one group can have up to 8 units.)
- Control is possible for ON/OFF, operation mode, fan speed, air flow direction, operation monitoring, alarm monitoring, ventilation, remote controller local operation prohibition, etc.

### Prohibition setting for Remote controller operation

Setting mode	ON/OFF	Mode	Temperature	Fan speed	Flap
Permit	●	●	●	●	●
Prohibit 1	—	●	●	●	●
Prohibit 2	—	—	—	●	●
Prohibit 3	●	—	—	●	●
Prohibit 4	●	—	●	●	●

In case of joint use with a wireless remote controller, there are limitations for the control mode. Please use only with setting "Permit" and "Prohibit1 (prohibition for ON/OFF)".

\*Contents for Prohibit 1~4 can be modified.  
● : Operation from the remote controller is possible.  
— : Operation from the remote controller is prohibited.

- Joint use with a remote controller, an intelligent controller, etc. is possible  
(The maximum number of connectable system controllers is 10, including other central controllers on the same circuit.)  
(In case of joint use with a wireless remote controller, there are limitations for the control mode. Please use only with setting "Permit" and "Prohibit1 (prohibition for ON/OFF)".)
- Control of systems without a remote controller and of main/sub systems (a total of up to 2 units) is possible
- Weekly timer function
  - 8 programs per day (with ON/OFF/Mode/Temperature/Central control setting items) for 1week (7days) can be set.
  - Special holiday setting can ignore the timer operation temporary by keeping original timer setting. (Special holiday setting can be removed by same setting display.)
- 5 types of Energy saving function  
Set temperature automatic return / Set temperature range limitation / Off remind / Off timer operation / Demand control timer

- A control mode corresponding to the use condition can be selected from 10 patterns

A : Operation mode: Central control mode or remote control mode can be selected  
Central control mode: The system controller is used as centralised control device. (Setting from a remote controller can be prohibited by prohibiting local operation from the system controller.)  
Remote control mode: The system controller is used as a remote controller. (Setting from the system controller can be prohibited by prohibiting local operation from another central control unit.)

B : Controlled unit number mode: All mode or zone 1, 2, 3, 4 mode can be selected  
All mode: All, zone, or group unit can be selected.  
Zone 1, 2, 3, 4 mode: Setting is possible only for the indoor units of zone 1, 2, 3, or 4.

Connection example		A Operation mode	
		Central control mode	Remote control mode
B Controlled unit number mode	All mode	All central control Example 1	All remote control
	Zone 1 mode	Zone 1 central control Example 2	Zone 1 remote control
	Zone 2 mode	Zone 2 central control	Zone 2 remote control Example 3
	Zone 3 mode	Zone 3 central control Example 4	Zone 3 remote control
	Zone 4 mode	Zone 4 central control	Zone 4 remote control Example 5

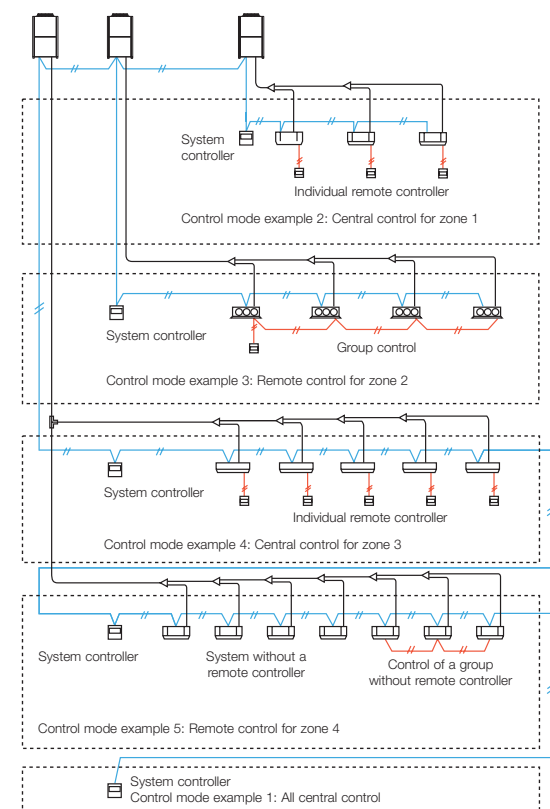

## ON/OFF controller (CZ-ANC2)

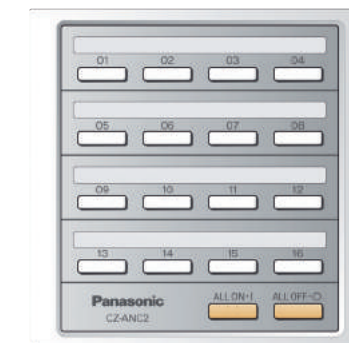

Dimensions  
H 121 x W 122 x D 14 + 52  
(embedding dimension mm)

Power supply: AC 220 to 240 V  
I/O part: Remote input (effective voltage: within DC 24 V): All ON/OFF  
Remote output (allowable voltage: within DC 30 V): All ON, All alarm

- 16 groups of indoor units can be controlled.
- Collective control and individual group (unit) control can also be performed.
- Up to 8 ON/OFF controller (4 main, 4 sub) can be installed in one link system.
- The operation status can be determined immediately.

Note: As operation mode and temperature settings are not possible with the ON/OFF controller, it must be used together with a remote controller, a system controller etc.

# Web Interface Systems

## Web Interface (CZ-CWIBC2)



(Dimensions: H 248 x W 185 x D 80 mm)  
AC 100 to 240 V (50/60Hz), 17 W

### Functions

- Access and operation by Web browser
- Icon display
- Language codes available in English, French, German, Italian, Portuguese, Spanish
- Individual control possible (max. 64 indoor units) ON/OFF operation mode, set temperature, fan speed, Flap set, timer on/off, alarm code monitoring, prohibit Remote Control
- All Units control
- Alarm Log
- Mail Sent Log
- Program Timer set 50 daily timers with 50 actions each day, 50 weekly timers, 1 holiday timer, 5 special day timers, for each tenant
- Prohibit Remote Control set
- IP ADDRESS could be changed via Internet

Note: It is recommended to install a remote controller or a system controller on site to enable local control if the network experiences a problem.

**Easy to set to every room by recognisable icon and user-friendly remote control window**  
If any of the indoor units is selected, the remote control window shown will be displayed for detailed setting modifications.

**Easy to manage and monitor each tenant use \***  
Each indoor unit or tenant otherwise all indoor units can be displayed and controlled. All unit statuses can also be displayed on one screen.

**Program Timer set**  
50 daily timers with 50 actions each day, 50 weekly timers, holiday timer, 5 special day timers, for each tenant.

Web Interface (CZ-CWIBC2)  
Indoor/outdoor control wire (non-polar)  
Link system  
LAN (10/100BASE-T)  
Internet  
PC (field supply)

Maximum number of connections:  
Indoor units: 64  
Outdoor units: 30  
Link system (Indoor/outdoor control wire) : 1

## Intelligent controller (CZ-256ESMC2)



Touch panel

Dimensions  
H 240 x W 280 x D 138 mm  
Power supply AC 100 to 240 V (50 Hz), 20 W (separate power supply)  
I/O part Remote input (voltage-free contact): All ON/OFF  
Remote output (voltage-free contact): All ON, All alarm (external power supply within DC 30 V, 0.5 A)  
Total wiring length: 1 km for each system  
Only for embedding in the panel

- Max 256 indoor units (4 systems x 64 units) can be controlled. In case of three or more systems (more than 128 units), a communication adapter CZ-CFUNC2 must be installed
- Operation is possible as batch, in zone units, in tenant and in group units
- ON/OFF, operation mode setting, temperature setting, for fan speed setting, air flow direction setting (when used without a remote controller), and remote controller local operation prohibition (prohibition 1, 2, 3, 4) can be done
- A system without a remote controller is possible. Joint use with a remote controller or a system controller is also possible
- Use of a schedule timer and holiday setting also can be done
- Proportional distribution of the air conditioning energy is possible. Including csv-file export via CF-card (supplementary accessory)
- Pulse signal input from electric/gas consumption meter

In case of joint use with a wireless remote control system, there are limitations for the control mode. Please use only with "Permission" and "Prohibition 1".

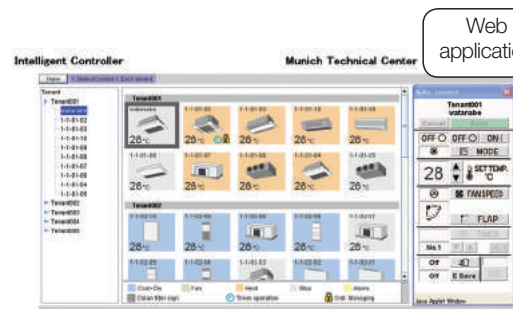

Web application

### • Limitation contents for prohibited operation

Prohibition means limitation of the operation contents from the remote controller. It is also possible to change the prohibition items.

#### Limitation contents (Limitations can be user defined)

- |               |  |
|---------------|--|
| Individual    | There is no limitation for the operation of the remote controller. However, the contents will be changed to the contents of the controller operated last. (Last-pressed priority.) |
| Prohibition 1 | The remote controller cannot be used for ON/OFF. (All other operations are possible from the remote controller.)   |
| Prohibition 2 | The remote controller cannot be used for ON/OFF, operation mode change and temperature setting. (All other operations are possible from the remote controller.)                    |
| Prohibition 3 | The remote controller cannot be used for operation mode change and temperature setting. (All other operations are possible from the remote controller.)                            |
| Prohibition 4 | The remote controller cannot be used for operation mode change. (All other operations are possible from the remote controller.)  |

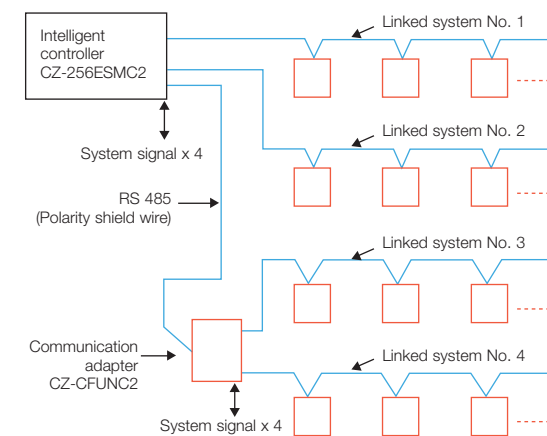

Display sample Max. 4 links can be connected for the indoor/outdoor operation line = Max. 64 indoor units x 4 (256 units) Max. 30 outdoor units x 4 (120 units)

### Communication adaptor (CZ-CFUNC2)

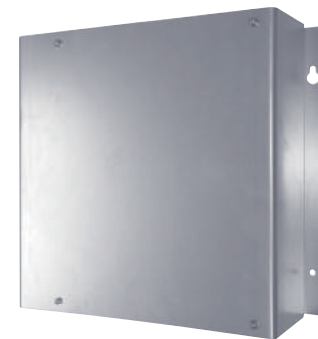

\* Required when more than 129 indoor units are connected.



# Panasonic total air conditioning management system P-AIMS

## P-AIMS Basic software / CZ-CSWKC2

Up to 1024 indoor units can be controlled by one PC

Functions of basic software

- Standard remote control for all indoor units
- Many timer schedule programs can be set on the calendar
- Detailed information display for alarms
- CSV file output with alarm history, operating status.
- Automatic data backup to HDD

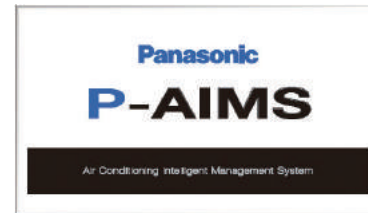

With 4 upgrade packages the basic software can be upgraded to suit individual requirements

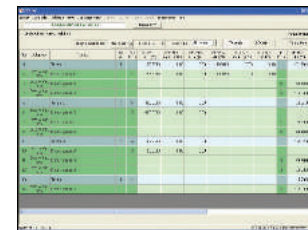
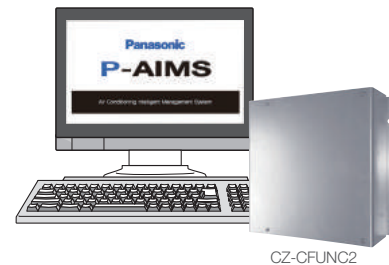

The P-AIMS is ideal for large areas/buildings such as shopping centers, universities and office buildings.

Up to eight Communication Adaptors (C/A) can be connected to a P-AIMS to enable control of 1024 indoor units with one "P-AIMS" PC.

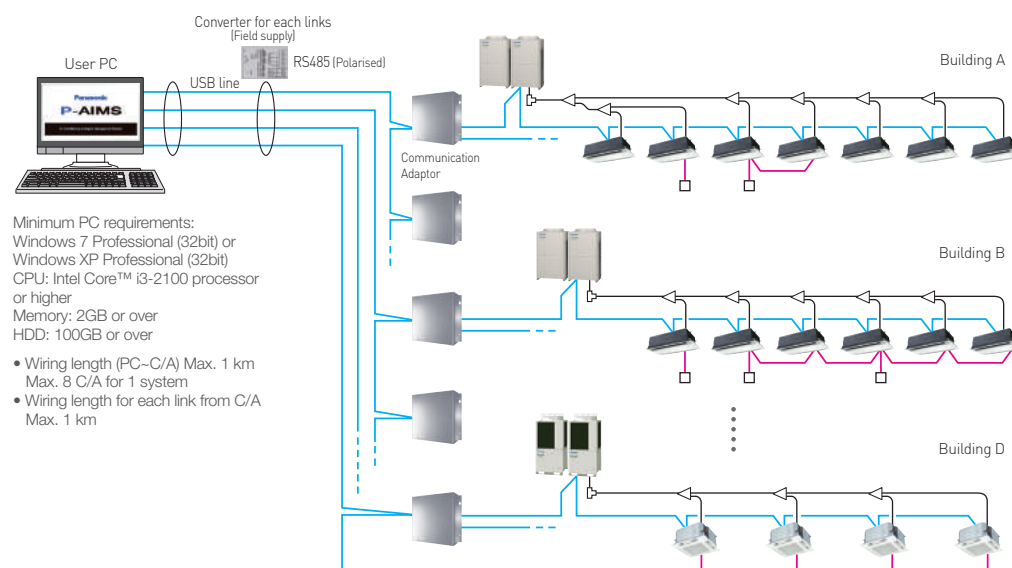

## P-AIMS optional software CZ-CSWAC2 for Load distribution

Load distribution calculation for each tenant

- Air-conditioner load distribution ratio is calculated for each unit (tenant) with used energy consumption data (m3, kWh).
- Calculated data is stored with CSV type file.
- Data of last 365 days is stored

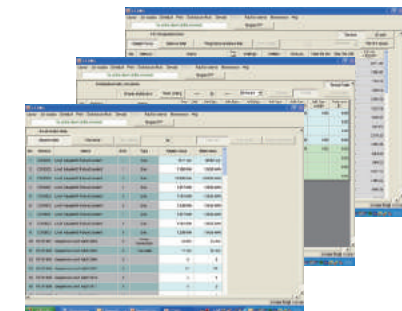

## P-AIMS optional software CZ-CSWWC2 for Web application

Web access & control from remote station

- Accessing P-AIMS software from remote PC.
- You can monitor/operate FSV systems by using Web browser (Internet Explorer).



## P-AIMS optional software CZ-CSWGC2 for Object layout display

Whole system can be controlled visually

- Operating status monitor is available on the layout display.
- Object's layout and indoor unit's location can be checked at once.
- Each unit can be controlled by virtual remote controller on the display.
- Max 4 layout screens are shown at once.

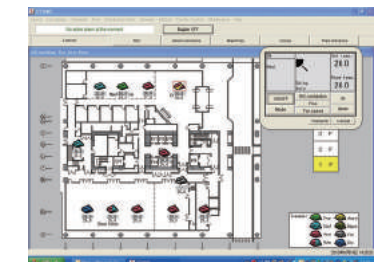

## P-AIMS optional software CZ-CSWBC2 for BACnet software interface

Connectable to BMS system

- Can communicate with other equipment by BACnet protocol.
- FSV systems can be controlled by both BMS and P-AIMS.
- Max 255 indoor units can be connected to 1 PC (that has P-AIMS basic & BACnet software).

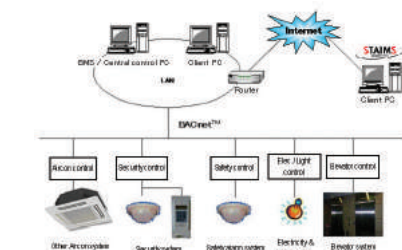

# T10 Terminal for External Control (Digital Connection)

Connecting an FSV indoor unit to an external device is easy. The T10 Terminal featured in the electronic circuit board of all indoor units enables digital connection to external devices.



## 1. T10 Terminal Specification (T10:CN061 at indoor unit PCB)

- Control items:
  - Start/stop input (eg hotel key card, push button operation)
  - Remote controller prohibit input
  - Operation status output (eg fresh air fan)
  - Fault status output

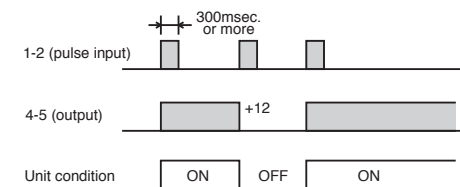

NOTE: The wire length from indoor unit to the Relay must be within 2.0m. Pulse signal changeable to static with JP cutting. (Refer to JP001)

## 2. Usage Example

### Forced OFF control

- Condition: 1-2 (Static input): Close/ Operation with Remote is permitted. (Normal condition) Open/ Unit is forcibly OFF and Remote controller operation is prohibited.

### Example of wiring

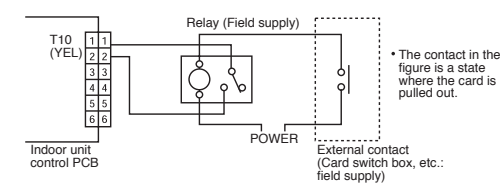

NOTE: The wire length from indoor unit to the Relay must be within 2.0m

### Example of wiring

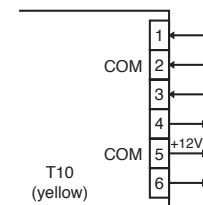

### Condition

- 1-2 (Pulse input): Unit ON/OFF condition switching with a pulse signal. (1 pulse signal: shortage status more than 300msec. or more)
- 2-3 (Static input): Oper/ Operation with Remote is permitted. (Normal condition) Close/ Remote controller is prohibited.
- 4-5 (Static output): 12V output during the unit ON. / No output at OFF.
- 5-6 (Static output): 12V output when some errors occur / No output at normal.

### Operation ON/OFF signal output

- Condition: 4-5 (Static output): 12V output during the unit ON / No output at OFF

### Example of wiring

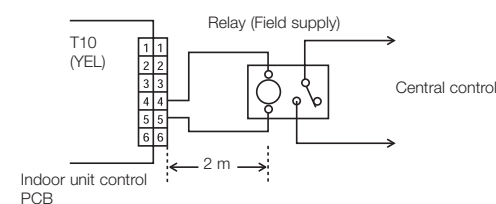

NOTE: The wire length from indoor unit to the Relay must be within 2.0m. Pulse signal changeable to static with JP cutting. (Refer to JP001)

# Interfaces for External Control (Digital Connection)

## Seri-Para I/O unit for each indoor unit (CZ-CAPBC2)



### System example

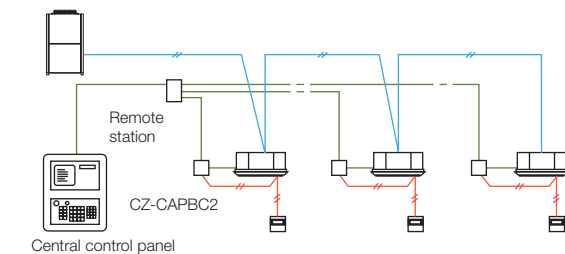

- Control and status monitoring is possible for individual indoor unit (1 group).
- In addition to operation and stop, there is a digital input function for air speed and operation mode.
- Temperature setting and measuring of the indoor suction temperature can be performed from central monitoring.
- The analog input for temperature setting is 0 to 10 V, or 0 to 140 Ohm.
- Power is supplied from the T10 terminal of the indoor units.
- Separate power supply also is possible (in case of suction temperature measuring).

## Interface adaptor (CZ-CAPC2)



### System example

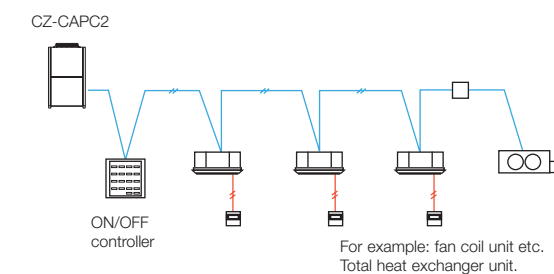

- Control and status monitoring is possible for individual indoor unit (or any external electrical device up to 250 V AC, 10 A) by contact signal.

## Seri-Para I/O unit for outdoor unit (CZ-CAPDC2)



### System example

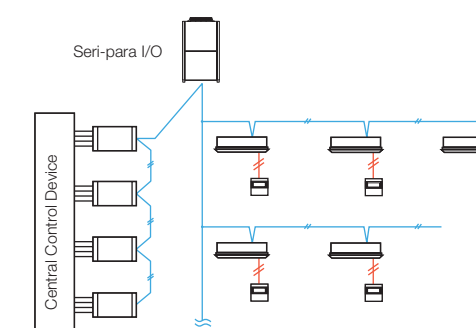

- Dimensions: H 80 x W 290 x D 260 mm
- Power supply: Single phase 110-120/220-240 V (50/60 Hz), 18 W
- Input: Batch operation/Batch stop (non-voltage contact/DC 24 V, pulse signal). Cooling/Heating (non-voltage contact/static signal). Demand 1/2 (non-voltage contact/static signal) (Local stop by switching)
- Output: Operation output (non-voltage contact). Alarm output (non-voltage contact)
- Wiring length: Indoor/Outdoor operation lines: Total length 1 km. Digital signal: 100 m or shorter

- This unit can control up to 4 outdoor units.
- From the centre control device, mode changing and batch operation/batch stop are possible.
- Required for demand control.

## Serial Interface for 3rd Party External Controller

Example of 3rd party BMS connection with CZ-CFUNC2  
(For the detail please consult to authorized dealer)

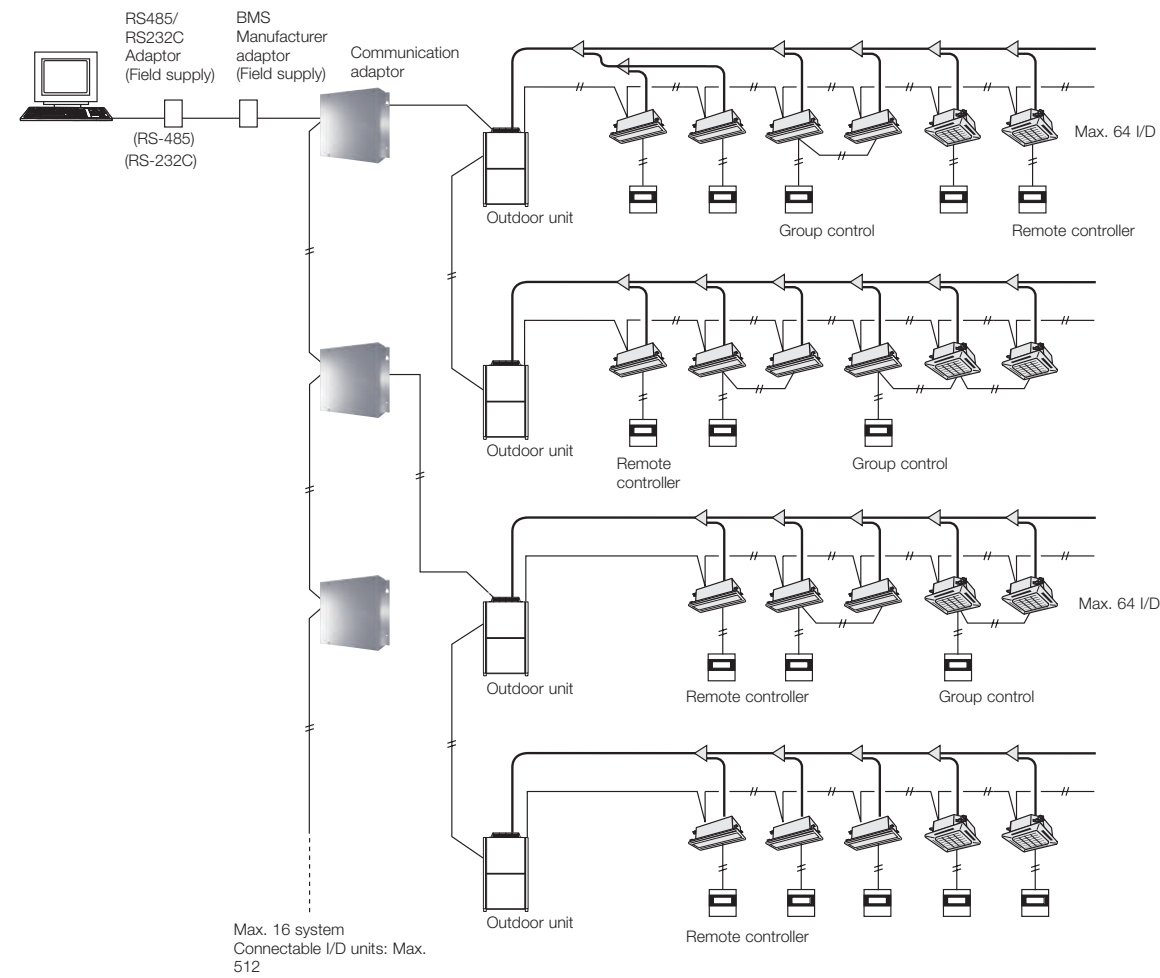

Functions via communication adaptor [CZ-CFUNC2]	
A/C unit settings	Unit ON/OFF
	Mode-change
	Room temperature setting
	Fan speed setting
	Flap setting
	Central control setting
	Filter-sign clear
	Alarm reset
	Unit ON/OFF status
	Operation mode
A/C unit status	Setting temperature
	Fan speed status
	Flap status
	Central control setting
	Filter-sign situation
	Correct/incorrect status
	Alarm code

### Communication Adaptor (CZ-CFUNC2)

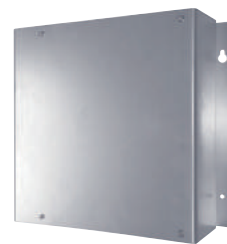

Up to 128 indoor units can be connected to one Communication Adaptor.

## Serial Interface for LonWorks Network

### LonWorks Interface (CZ-CLNC2)

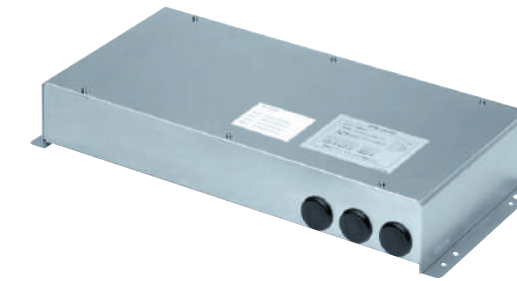

- This interface is a communications converter for connecting LonWorks to the control network of FSV.
- From the host connected to LonWorks, basic settings and status monitoring is possible for up to 16 groups of indoor units.

### System example

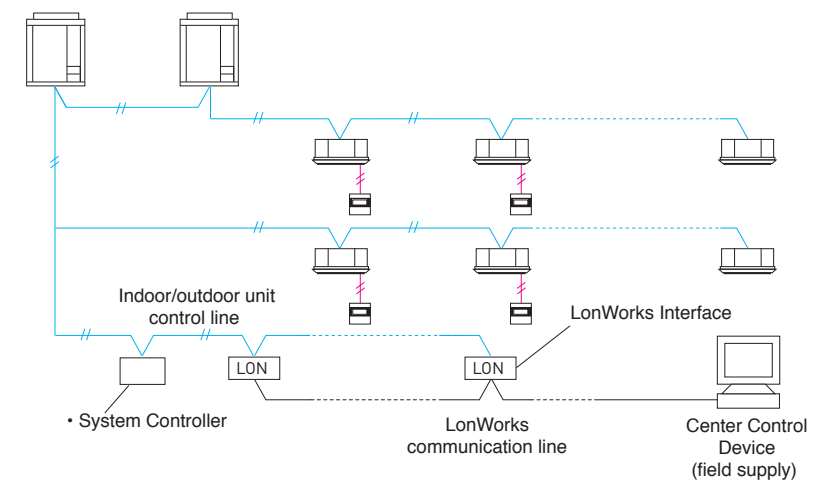

### Functions

A/C unit settings from the LonWorks communicator	Settings for each group of indoor units	Start/stop
	Settings for all units	Temp. setting
		Operation mode
	A/C unit status notifications made to the LonWorks communicator	Option 1 settings
Option 2 settings		Option 2 settings
Emergency stop		Emergency stop
Start/stop		Start/stop
Temp setting		Temp setting
Operation mode		Operation mode
Option 1 settings		Option 1 settings
Option 2 settings		Option 2 settings
Alarm status		Alarm status
Indoor units with active alarms		Indoor units with active alarms
Configuration properties	Room temp.	Room temp.
	A/C unit status	A/C unit status
	Transmission intervals settings	Transmission intervals settings
	Minimum time secured for transmission	Minimum time secured for transmission

# FSV Controller External Dimensions

HIGH-SPEC WIRED REMOTE CONTROLLER (CZ-RTC5)

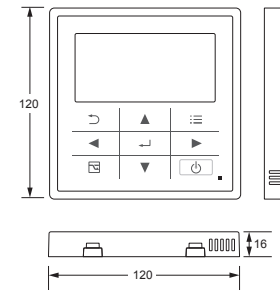

TIMER REMOTE CONTROLLER (CZ-RTC4)

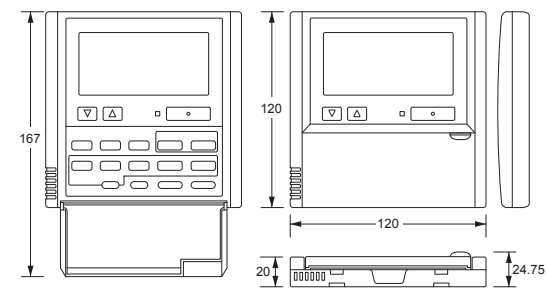

COMMUNICATION ADAPTOR (CZ-CFUNC2)

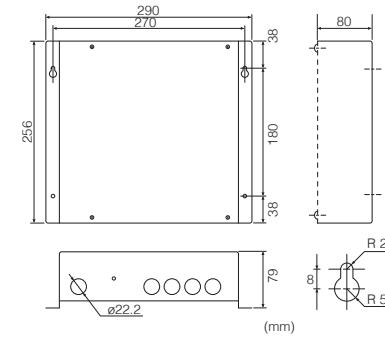

INTELLIGENT CONTROLLER (CZ-256ESMC2)

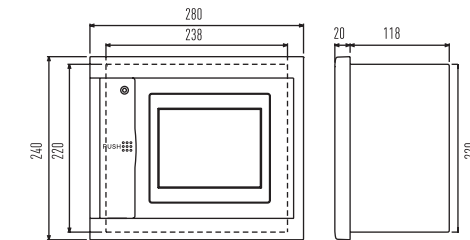

WIRELESS REMOTE CONTROLLER

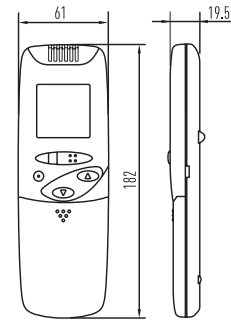

SEPARATE RECEIVER FOR WIRELESS REMOTE CONTROLLER (CZ-RWSC3)

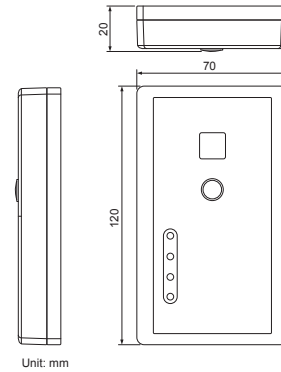

ON/OFF CONTROLLER (CZ-ANC2)

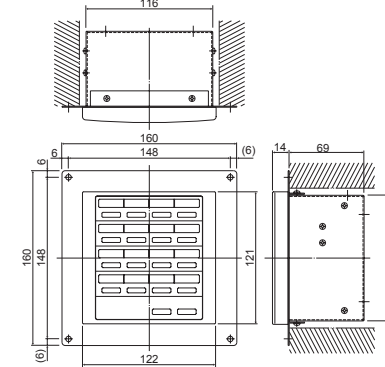

SERI-PARA I/O UNIT FOR EACH INDOOR UNIT (CZ-CAPBC2)

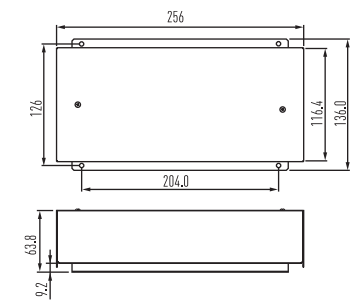

SIMPLIFIED REMOTE CONTROLLER (CZ-RE2C2)

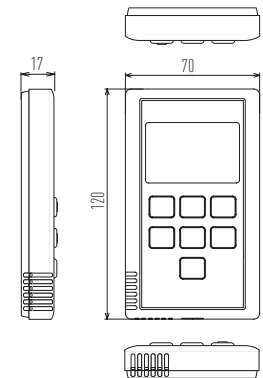

SYSTEM CONTROLLER (CZ-64ESMC2)

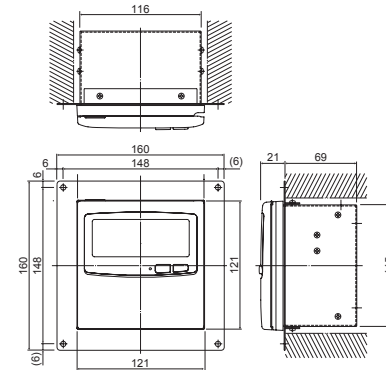

LONWORKS INTERFACE (CZ-CLNC2)

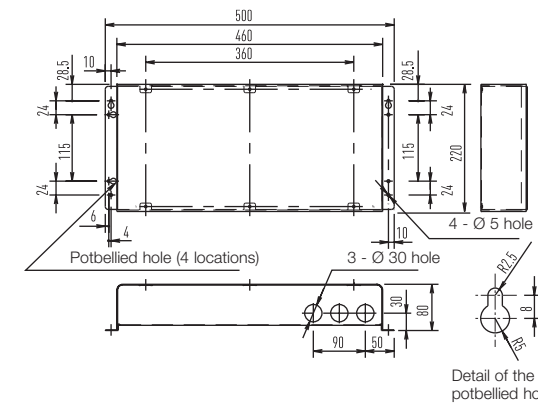

SERI-PARA I/O UNIT FOR OUTDOOR UNIT (CZ-CAPDC2)

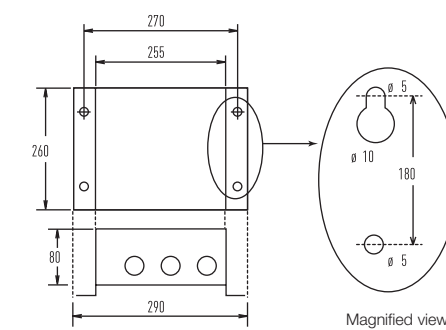

ECONAVI SENSOR (CZ-CENSC1)

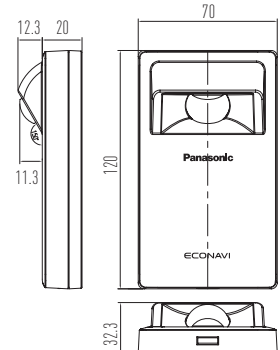

REMOTE SENSOR (CZ-CSRC3)

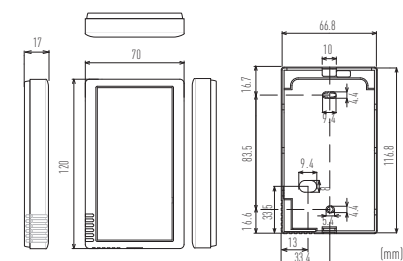

# VRF Renewal

An important drive to further reduce the potential damage to our ozone



R22 is a HCFC and classified as an ozone depleting substance banned under the Montreal Protocol. Many existing R22 VRF Systems will need to be replaced over the coming years by more modern and efficient R410A VRF Systems.

## Panasonic takes proactive action to switch to R410A refrigerant

Recognising consumers' anxiety and financial difficulties to adapt to the new R22 regulations, Panasonic developed a new cost-effective and simple solution to switch to R410A refrigerant.

### What is Panasonic VRF Renewal?

Panasonic VRF Renewal enables reuse of good quality existing R22 pipe work to be installed with a new high efficiency R410A system.

### What's so unique about Panasonic's solution?

By enabling reuse of existing R22 piping, consumers get to save substantially from reduced installation cost, and without any sacrifices to warranty or performance.

Ozone Depletion Potential		
R22	HCFCs	0.055
R410A	HFC	0
R407C	HFC	0

R22 - The reduction of Chlorine critical for a cleaner future

Before renewing piping, be sure to contact an authorised Panasonic dealer for advice.

## VRF Renewal

Panasonic's Renewal system allows a completely new VRF system, indoor and outdoor units, to be installed using the existing systems pipe work. Panasonic's advanced technology enables the system to work with previously installed pipe work by managing the working pressure within the system down to R22 (3.3 bar) levels. This ensures the system works safely and efficiently without loss of capacity.

The new equipment has potential to increase COP/EER by using state of the art inverter compressor and heat exchanger technology.

Having contacted your Panasonic supplier regarding pipe work restrictions and gained approval to use the Panasonic Renewal System there are three main tests that have to be carried out to ensure that the system can be used effectively.

Firstly a thorough inspection of the pipe work must be carried out and any damage must be repaired.

Secondly an oil test has to be carried out to ensure that the system has not been subject to a compressor burnout during its lifetime.

Lastly a VRF Renewal Kit (CZ-SLK2) has to be installed within the pipe work to ensure that the system is cleaned of any oil residue.

## VRF Renewal Kit (CZ-SLK2) and Sight Glass

The following shows an overview of the VRF Renewal Kit (CZ-SLK2) that is required when existing tubing is reused. If the exact tube length and tube size of the existing tubing are uncertain, attach a sight glass in accordance with the figure below. It will be used for checking the amount of additional refrigerant charge (calculating the amount in Judgment 4 see page 122).

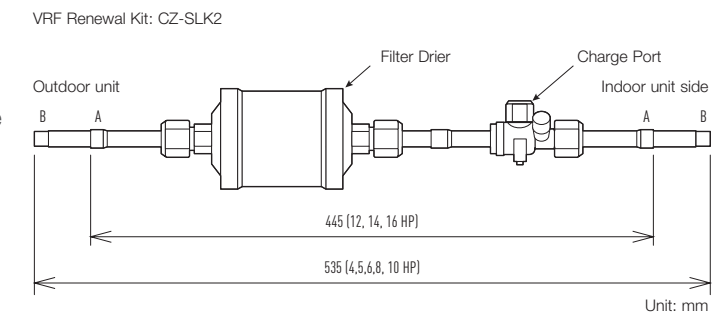

## Attaching the Renewal Kit and sight glass

- To adjust the limited pressure level into 3.3 MPa, special setting is necessary on site.
- A filter drier shall be attached to the liquid tubing of each outdoor unit.
- Do not need to remove Renewal Kit after a test run is performed as it can be retained for normal operation.
- When attaching Renewal Kit, be extra careful with regards to installation location and orientation of the filter drier and ball valve. Any mistakes will complicate maintenance work.
- Thermal insulation material (field supply: heat resistance of 80°C or higher and thickness of 10 mm or greater) shall be applied to the Renewal Kit.
- The filter drier of the Renewal Kit may need to be replaced depending on the condition of the existing unit. Use a Danfoss DMB 164 as the replacement filter drier (field supply).

## Connecting tube dimensions (Inch mm)

- A Ø 1/2 (12.7) (12,14,16 HP)
- B Ø 3/8 (9.52) (8,10 HP)

Note: If the tube size does not match that of the existing tubing, use a reducer (field supply) to adjust the tube diameter.

## Sight glass (field supply)

If the exact tube length and tube size of the existing tubing are uncertain, attach a sight glass to the liquid tubing, and use it to check whether there is an appropriate amount of additional refrigerant charge.

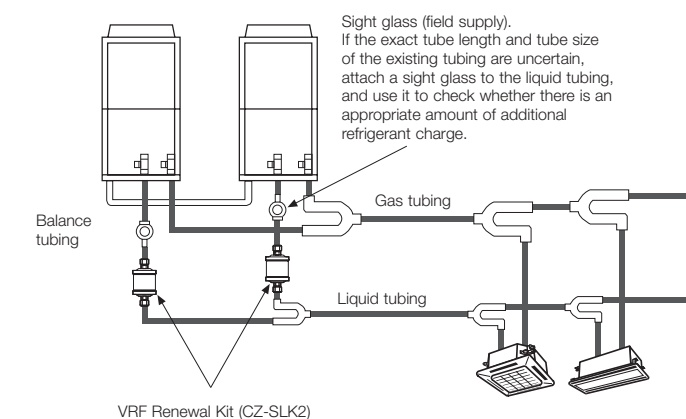



# Procedure for VRF Renewal

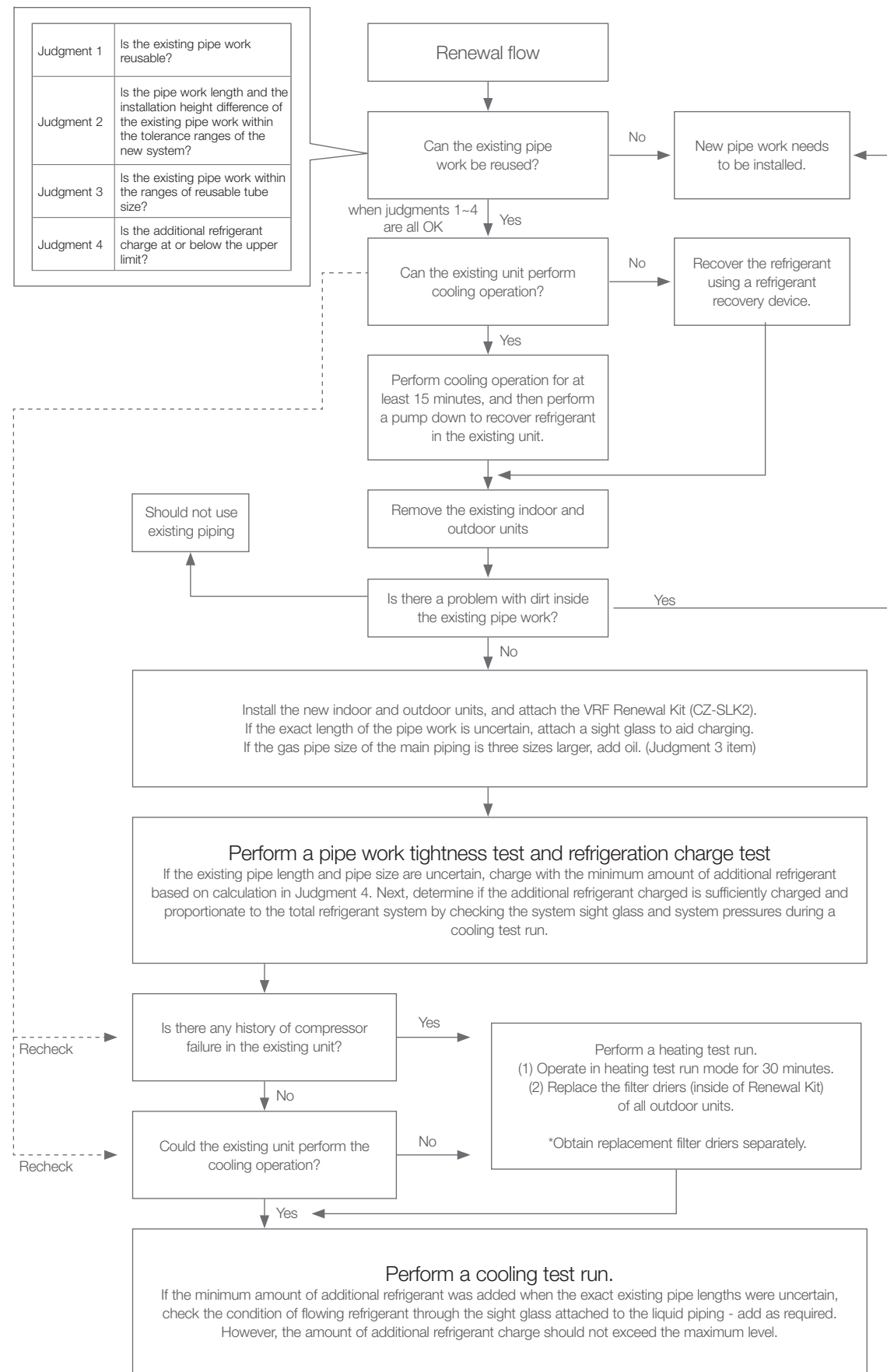

# A Globally Trusted Air Conditioning Brand

With roots going back 56 years, the Panasonic Air Conditioning Business Division has grown to become a multinational company recognised around the world. Driven by a never-ending quest for product innovation, the group has evolved from manufacturing compressors to providing comprehensive air conditioning solutions. Panasonic has become a brand that people trust to deliver products with superior quality and reliability.

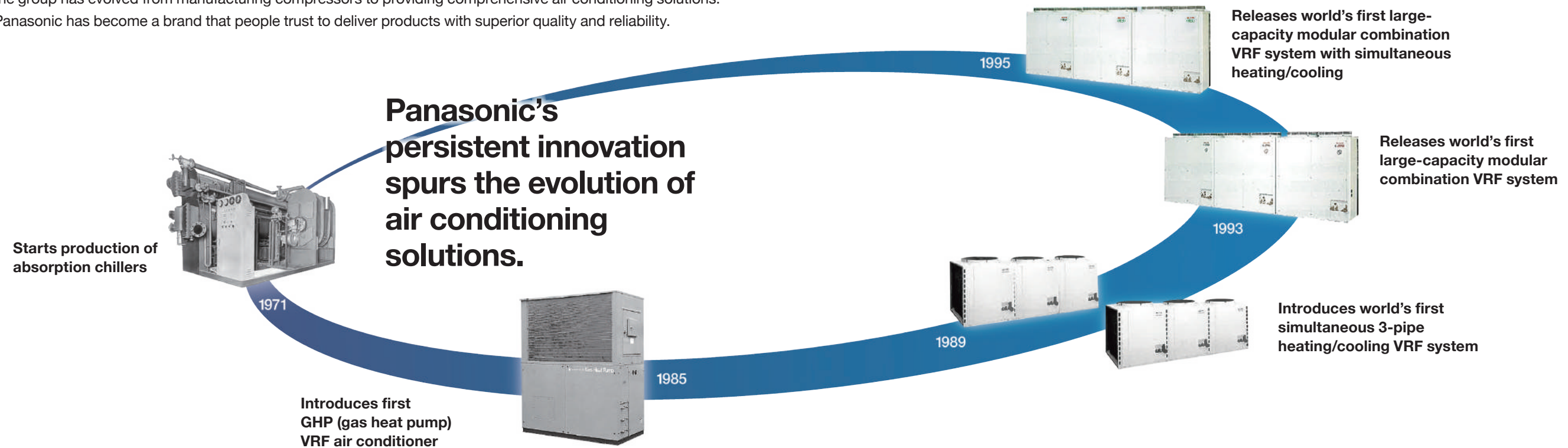

## 1958

- Panasonic (using the National brand) introduces its first Home Cooler, a window-type air conditioner model



- Electrical Appliance Business Group (Kadoma) starts manufacture of Home Coolers
- Sales of Home Coolers begin

## 1961

- Starts exports of Home Coolers to South Vietnam

## 1965

- Launches Room Coolers



## 1968

- Begins development of rotary compressors
- The high efficiency and quality of these compressors draws interest from domestic and overseas air conditioner manufacturers
- External sales begin

## 1972

- MAICO, the Division's first overseas manufacturing base, established in Malaysia
- Starts exports from MAICO to Japan, Indonesia, Australia, and other markets
- Begins operating twin-base system out of Japan and Malaysia



## 1983

- Launches inverter air conditioners
- Starts sales of Panasonic's first inverter air conditioners
- Inverters grow to become core technology in air conditioner industry
- Starts shipments of air conditioners to Panasonic America

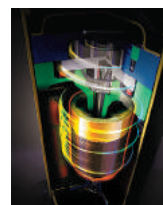

## 1985

- Begins development of scroll compressors
- Scroll compressors bring high efficiency, low noise, and low vibration in comparison to rotary compressors

## 1990

- Launches world's first air conditioner equipped with compact scroll compressor

## 1993

- Establishes Matsushita-Wanbao (Guangzhou) Air Conditioner (MWAC)
- Establishes Matsushita-Wanbao (Guangzhou) Compressor (MWCC)
- Establishes Matsushita Air Conditioner Engineering (Matsushita ACE)

## 1995

- Releases world's first large-capacity modular combination VRF system with simultaneous heating/cooling

## 2003

- Debuts quiet, lightweight, compact EcoCute systems with improved energy-saving technology
- EcoCute adopts highly efficient, accumulator-less CO<sub>2</sub> scroll compressor
- Begins production of new energy-saving mini-VRF series multi-split packaged air conditioners for residential use
- CO<sub>2</sub> heat-pump hot water heater (EcoCute) uses non-toxic, non-combustible natural refrigerant (CO<sub>2</sub>) instead of Freon, to reduce environmental impact
- Launches automatic filter-cleaning function for air conditioners (AC robot)



## 2005

- Panasonic products become extremely successful in Japan's air conditioner market
- Innovations such as airstream robots and motion sensors help grow Panasonic's market share

## 2006

- Cumulative global production of Panasonic compressors reaches 200 million units

## 2008

- Starts air-to-water heat pump business in Europe
- Hot water heating considered eco-friendly alternative to conventional fuel-type heating systems
- At the Energy Conservation Grand Prize awards, Panasonic air conditioners win Chairman's Award, whilst EcoCute wins Director General Prize (prizes presented by Energy Conservation Center of Japan)



## 2009

- Establishes sales company in Europe (PHAAE) dedicated to selling air conditioners
- Panasonic HA Air-Conditioning Europe (PHAAE) strengthens company's commercial air conditioning business

## 2010

- Begins collaboration with SANYO air conditioner business
- Through share exchange, SANYO and Panasonic Electric Works become wholly owned subsidiary

## 2011

- Launches FSV series of large-capacity VRF air conditioners

## 2012

- New Panasonic Group inaugurated

## 2013

- Expands VRF operation in Malaysia



# Reliability and Durability

At Panasonic, we believe that the best air conditioner is one that works quietly and effectively in the background whilst minimising its impact on the environment. People who use our products can look forward to long years of high-quality performance without the need for constant maintenance.

As part of our rigorous design and development process, Panasonic air conditioners undergo a variety of stringent tests to ensure their effectiveness and long-term reliability. Tests for durability, waterproofing, shock resistance, and noise are conducted on component parts or on the finished products themselves. As a result of all of these painstaking efforts, Panasonic air conditioners meet even the most demanding industrial standards and regulations in every country where they are sold.



Applying advanced technologies that truly make life better, we live by an unparalleled commitment to product quality. Our approach to product development originates in the DNA of Japanese craftsmanship.

Panasonic is building on the Japanese tradition of uncompromising quality control worldwide, developing and manufacturing fine products and delivering them to customers everywhere.

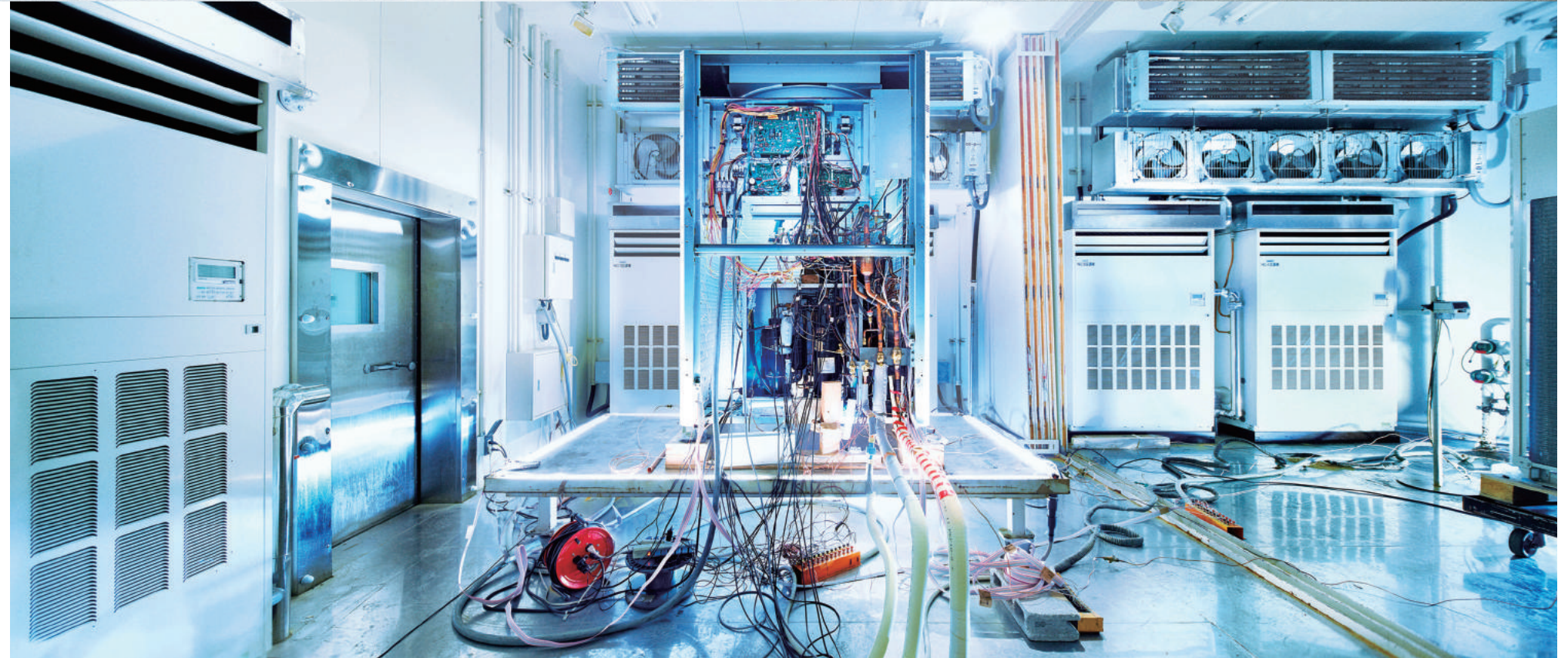

Testing laboratory Panasonic Gunma, Japan (PAPARS)

## Durability

At Panasonic we know the importance of a long service life with minimal maintenance. That's why we subject our air conditioners to a wide range of stringent durability tests.



### Long-Term Durability Test

To ensure durability and stable operation for many years, we conduct a long-term continuous operation test under conditions that are much more severe than actual operating conditions.



### Compressor Reliability Test

After the continuous operation test, we remove the compressor from a selected outdoor unit, disassemble it, and examine the internal mechanisms and parts for potential failure. This helps ensure reliable long-term performance under harsh conditions.

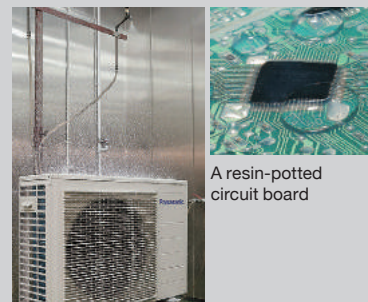

A resin-potted circuit board

### Waterproofing Test

The outdoor unit, which is subject to rain and wind, complies with IPX4 waterproof specifications. Contact sections on printed circuit boards are resin-potted to prevent adverse effects caused by exposure to water (an unlikely occurrence).

## International Standard Quality

To uphold the company's reputation around the world, Panasonic strives continuously to offer the highest quality with the lowest possible environment impact.



The strength of the resin material used in a propeller fan is confirmed by a tension test

### Reliable Parts That Meet or Exceed Industrial Standards

In every country where they are sold, Panasonic air conditioners comply with all required industrial standards and regulations. In addition, Panasonic conducts stringent testing to ensure the reliability of parts and materials.



### RoHS / REACH Compliant Parts

All Panasonic parts and materials comply with Europe's strict RoHS/REACH environmental regulations. During the development and production of parts, stringent inspections are conducted on over 100 materials to ensure that no hazardous substances are included.



### Sophisticated Production Process

Panasonic's air conditioner production lines employ state-of-the-art factory automation technologies to ensure products are manufactured efficiently and with uniformly high levels of quality and reliability.

# Global Networking of Air Conditioning Solutions

In any indoor environment, eco-friendly air conditioning plays a vital role in maintaining our health, comfort, and productivity. Whether it's an office, a hotel, or a shopping mall, every building matters. That's why Panasonic has developed energy-efficient large-scale air conditioning solutions to suit a variety of business applications.

As one of the pillars of Panasonic's BtoB operations, our air conditioning sector provides comprehensive solutions to businesses around the world. Harnessing our advanced technology and extensive on-site expertise, we serve clients in a diverse range of environments throughout the world.

Panasonic air conditioning solutions are designed from the ground up to meet the specific needs of each location, whilst placing a premium on efficiency and reliability. At every stage, we seek to make optimal use of resources and energy to create solutions that benefit the environment.



## PACT Training Facilities

The 24 Panasonic Air Conditioning Training Centers (PACTs) around the world provide a wide range of support for Panasonic's business-use air conditioning systems. PACT represents Panasonic's unwavering commitment to our sales partners, distributors, and service teams in Europe, Asia, Oceania, and the Americas.

**FS MULTI**  
AIR CONDITIONING SYSTEM



**FSV**



## Quality Assurance from Japan to the World

With a diverse network of production and R&D facilities, Panasonic delivers innovative products incorporating cutting-edge technologies that set the standard for air conditioners worldwide. As our business expands globally, we strive to transcend borders with our superior-quality products.

### Japan



Air Conditioning Division (Appliances Company) (Shiga, Japan)

Established April 1972  
• Appliances Company HQ  
• Home Appliances Business Group  
• Corporate Engineering Division



PAPARS Panasonic Appliances Air Conditioning & Refrigeration System (Gunma, Japan)

Established July 1959  
• Air conditioners  
• Cold-chain/refrigeration products

### Malaysia



PAPAMY Panasonic Appliances Air Conditioning Malaysia Sdn Bhd.

Established April 1972  
• Air conditioners  
• Air-to-water heat pumps



PAPANADMY Panasonic Appliances Air Conditioning R&D Malaysia Sdn Bhd.

Established June 1991  
• R&D for air conditioners  
• Air-to-water heat pumps



PAPANAMY Compressor

Established January 1987  
• Rotary compressors for air conditioners



PAPANAMY Compressor R&D

Established September 1997  
• R&D for rotary compressors

### China



PAPANAGZ Panasonic Appliances Air Conditioning (Guangzhou) Co., Ltd.

Established June 1993  
Air conditioners



PAPANAPCGZ Panasonic Wanbao Appliances Compressor (Guangzhou) Co., Ltd.

Established June 1993  
• Rotary compressors for air conditioners  
• Compressors for automotive air conditioners



PAPANPRDCS Panasonic R&D Center Suzhou Co., Ltd.

Established April 2002  
• Air conditioners  
• R&D for home appliance products

PAPANPARDL Panasonic Appliances Air-Conditioning and Refrigeration (Dalian) Co., Ltd.

Established December 1995  
• Air conditioners

### Taiwan



PTW Panasonic Taiwan Co., Ltd.

Established October 1962  
• Air conditioners  
• Automotive air conditioners  
• Home appliance products



PMI Panasonic Manufacturing Indonesia

Established September 1965  
• Air conditioners  
• Home appliance products



PMPC Panasonic Manufacturing Philippines Corporation

Established September 1967  
• Air conditioners  
• Home appliance products



APIN Panasonic Appliances Company India

Established December 2012  
• Air conditioners

## PACT Headquarters and Bases

### EUROPE

#### Germany Wiesbaden



#### Nordic Stockholm



#### Russia (CIS) Moscow



#### Spain Madrid



#### Italy Milan

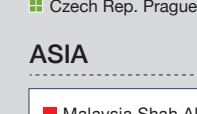

#### Czech Rep. Prague

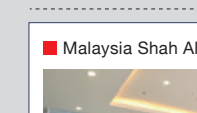

#### Hungary Budapest



#### Spain Barcelona



#### France Paris



#### France Lyon



#### UK Bracknell



### ASIA

#### Malaysia Shah Alam



#### Vietnam Hanoi



#### Thailand Bangkok

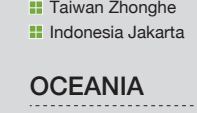

#### Taiwan Zhonghe



#### Indonesia Jakarta



#### India New Delhi



#### China

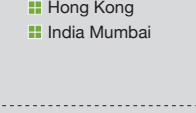

#### Hong Kong

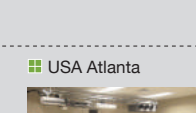

#### India Mumbai



### OCEANIA

#### Australia Sydney

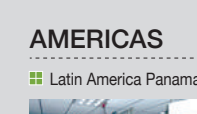

#### New Zealand Auckland

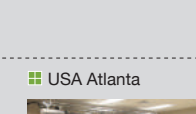

### AMERICAS

#### Latin America Panama



#### USA Atlanta



# Panasonic VRF Global Project References

Panasonic air conditioning systems provides comprehensive solutions to businesses around the world. Harnessing our advanced technology and extensive on-site expertise, we serve clients in a diverse range of environments throughout the world.

## HOTEL

**Australia** Travelodge Hobart



Air Conditioning System:  
VRF 3-way FSV MF2 series 8 systems  
Indoor Units: 116 units  
Cooling Capacity:  
302 kW / 86 USRT



**Indonesia** Patra Jasa Hotel

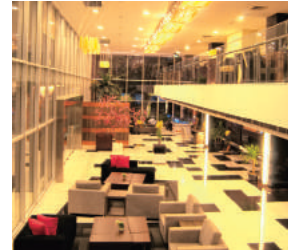

Air Conditioning System:  
VRF 2-way FSV ME1 series 14 systems  
Indoor Units: 132 units  
Cooling Capacity:  
677 kW / 193 USRT



**Spain** Hotel Claris 5 GL



Air Conditioning System:  
VRF 2-way ECOi ME1&LE1 series 11 systems  
VRF 3-way ECOi MF1 series 14 systems  
Indoor Units: 233 units  
Cooling Capacity:  
769 kW / 218 USRT



**Siberia** River Park Hotel



Air Conditioning System:  
VRF 2-way ECOi ME1 series 47 systems  
Indoor Units: 96 units  
Cooling Capacity: 788 kW / 224 USRT

## OFFICE

**Malaysia** Gaprana project



Air Conditioning System:  
VRF 2-way FSV ME1 series 109 systems  
Indoor Units: 537 units  
Cooling Capacity:  
5,370 kW / 1,526 USRT



**Malaysia** Plaza 33 Office Block A



Air Conditioning System:  
VRF 2-way FSV ME1 series 99 systems  
Indoor Units: 153 units  
Cooling Capacity:  
3,667 kW / 1,042 USRT



**Thailand** Areeya



Air Conditioning System:  
VRF 2-way FSV ME1 series 19 systems  
Single split system 67 systems  
Indoor Units: 85 units  
Cooling Capacity:  
1,519 kW / 432 USRT



**HongKong** King Yip Road



Air Conditioning System:  
VRF FSM LA1 series 136 systems  
Indoor Units: 294 units  
Cooling Capacity:  
2,108 kW / 599 USRT



**New Zealand** 151 Cambridge Terrace



Air Conditioning System:  
VRF 3-way FSV MF2 series: 20 systems  
Indoor Units: 75 units  
Cooling Capacity:  
850 kW / 242 USRT



**New Zealand** IAG Christchurch



Air Conditioning System:  
VRF 3-way FSV MF2 series: 25 systems  
Indoor Units: 132 units  
Cooling Capacity:  
976 kW / 278 USRT



**Spain** PTA Malaga



Air Conditioning System:  
VRF 2-way ECOi ME1 series 20 systems  
Indoor Units: 74 units  
Cooling Capacity:  
908 kW / 258 USRT



**Russia** Russian Government Building



Air Conditioning System:  
VRF 2-way ECOi ME1 series 42 systems  
Indoor Units: 277 units  
Cooling Capacity:  
2,045 kW / 581 USRT

## RETAIL

**Italy** Le Centurie CENTRO COMMERCIALE



Air Conditioning System:  
VRF 3-way ECOi MF1 series 18 systems  
Indoor Units: 57 units  
Cooling Capacity:  
656 kW / 186 USRT



**India** Sai Aarav Motors, Mehsana



Air Conditioning System:  
VRF 2-way FSV ME1 series 3 systems  
Indoor Units: 19 units  
Cooling Capacity: 156 kW / 44 USRT

**Thailand** Jiffy Plus Supermarket



Total 49 branches in Thailand Region  
Air Conditioning System:  
VRF 2-way FSV ME1 series:  
49 systems  
Indoor Units: 191 units  
Cooling Capacity:  
3,590 kW / 1,020 USRT



## HOSPITAL

**Indonesia** Bekasi Hospital



Air Conditioning System:  
VRF 2-way FSV ME1 series 42 systems  
Indoor Units: 283 units  
Cooling Capacity:  
1,834 kW / 524 USRT



**Indonesia** Persada Hospital



Air Conditioning System:  
VRF 2-way FSV ME1 series 21 systems  
Indoor Units: 116 units  
Cooling Capacity:  
989 kW / 281 USRT



**United States** Shippensburg University



Air Conditioning System:  
VRF 3-Way ECOi MF1 series 55 systems  
Indoor Units: 530 units  
Cooling Capacity:  
1,498 kW / 426 USRT



**Thailand** Kalasin College of Dramatic Arts



Air Conditioning System:  
VRF 2-way FSV ME1 series: 5 systems  
Indoor Units: 53 units  
Cooling Capacity:  
646 kW / 184 USRT



## RESIDENTIAL

**China** Star River Group Luxury Condominium



Air Conditioning System:  
VRF Master series 966 systems  
Indoor Units: 3,948 systems  
Cooling Capacity:  
16,737 kW / 4,755 USRT



**Spain** Xativa GHP



Air Conditioning System:  
Gas-driven VRF 2-way ECO G 8 systems  
Indoor Units: Hydrokit water heat exchanger: 8 units  
Cooling Capacity: 624 kW / 177 USRT



**Hong Kong** Gloucester Road Project



Air Conditioning System:  
VRF FSM LA1 series 67 systems  
Twenty series 105 systems  
Indoor Units: 255 units  
Cooling Capacity: 1,391 kW / 395 USRT

**Hong Kong** The Green Project



Air Conditioning System:  
VRF FSM LA1 series 239 systems  
Indoor Units: 999 units  
Cooling Capacity:  
6,425 kW / 1,825 USRT



**Panama** Mosaic Building PANAMA PACIFICO



Air Conditioning System:  
VRF 2-way FSV LE1 series 156 systems  
Indoor Units: 357 units  
Cooling Capacity: 2,338 kW / 664 USRT

**Australia** Macquarie Central



Air Conditioning System:  
VRF 3-way FSV MF2 series: 13 systems  
Indoor Units: 144 units  
Cooling Capacity:  
768 kW / 218 USRT



# MEMO

---

---

---

---

---

---

---

---

---

---

---

---

---

---

---

---

---

---

---

---

---

---

---

---

---

---

---

---

---

---

---

---

---

---

---

---

---

---

---

---

---

---

---

---

---

---

---

---

---

---

---

---

---

---

---

---

---

---